

ANEXO 2

Escenario de demanda media y estación seca del mes de marzo

Evaluación de la Estabilidad del Voltaje - 2008

1. ANÁLISIS DE FLUJO DE CARGA DEL CASO BASE.....	4
1.1. CASO SIN INTERCAMBIO DE POTENCIA EN LAS INTERCONEXIONES.....	4
2. IDENTIFICACIÓN DE LAS AREA LOCALES	6
2.1. CURVAS Q-V CON Y SIN COMPENSACIÓN:	6
3. ANÁLISIS DE CONTINGENCIAS DE LA RED DE TRANSMISIÓN	15
3.1. CONTINGENCIAS N-1.....	15
3.1.1. CASO A: CERO INTERCAMBIO DE POTENCIA EN LAS INTERCONEXIONES (CASO BASE)	16
3.1.2. CASO B: MÁXIMA TRANSFERENCIA GUATEMALA --> EL SALVADOR 40 MW.....	16
3.1.3. CASO C: MÁXIMA TRANSFERENCIA EL SALVADOR --> GUATEMALA 106 MW	17
3.1.4. CASO D: MÁXIMA TRANSFERENCIA HONDURAS --> EL SALVADOR 80 MW	18
3.1.5. CASO E: MÁXIMA TRANSFERENCIA EL SALVADOR--> HONDURAS 91 MW	19
3.2. CONTINGENCIAS N-2.....	20
3.2.1. CASO A: CERO INTERCAMBIO DE POTENCIA EN LAS INTERCONEXIONES (CASO BASE)	20
3.2.2. CASO B: MÁXIMA TRANSFERENCIA GUATEMALA --> EL SALVADOR 40 MW.....	26
3.2.3. CASO C: MÁXIMA TRANSFERENCIA EL SALVADOR --> GUATEMALA 106 MW	33
3.2.4. CASO D: MÁXIMA TRANSFERENCIA HONDURAS --> EL SALVADOR 80 MW	40
3.2.5. CASO E: MÁXIMA TRANSFERENCIA EL SALVADOR--> HONDURAS 91 MW	47
3.3. RESULTADOS Y CONCLUSIONES:	53
4. SELECCIÓN DE CONTINGENCIAS CRITICAS.....	55
4.1. RESERVA DE REACTIVOS PARA CONTINGENCIAS N-1.....	55
4.1.1. NODO 115 kV DE SAN MIGUEL	55
4.1.2. NODO 115 kV DE TECOLUCA	56
4.1.3. NODO 115 kV DE OZATLÁN	56
4.1.4. NODOS 115 kV DE SANTO TOMÁS	57
4.1.5. NODOS 115 kV DE EL PEDREGAL.....	57
4.1.6. NODO 115 kV DE SAN ANTONIO ABAD.....	58
4.2. RESERVA DE REACTIVOS PARA CONTINGENCIAS N-2.....	59
4.3. CÁLCULO DEL MARGEN DE RESERVA REACTIVA	60
4.4. DETERMINACIÓN DE LAS CURVAS P-V DE LAS CONTINGENCIAS CRÍTICAS	64
4.4.1. CASO 1: BERL-SMIG & SMIG-OZAT	65
4.4.2. CASO 2: SMAR-STOM & ACAJ-ATEO	66
4.4.3. CASO3: SRAF-TECO & 15SE-U1	67
4.4.4. CASO 4: SRAF-TECO & NCUS-ATEO	69
4.4.5. CASOS 5: SMAR-STOM & ACAJ-U5	70
4.4.6. CASO 6:BERL-SMIG & 15SE-U1	72
4.4.7. CASO 7: SRAF-TECO & 15SE-SMIG.....	73
4.4.8. CASO 8: NCUS-ATEO & SANT-ATEO.....	75
4.4.9. CASO 9: SANT-NEJA & ACAJ-ATEO	76
4.5. ANÁLISIS DE LAS CURVAS PV	79

4.6.	DETERMINACIÓN DEL TIEMPO DE RETARDO PARA INICIAR DISPARO DE CARGA	82
4.6.1.	FALLA TRIFÁSICA Y DISPARO DE LÍNEA BERL-SMIG	83
4.6.2.	FALLA TRIFÁSICA Y DISPARO DE LÍNEA SRAF-TECO	83
4.6.3.	FALLA TRIFÁSICA Y DISPARO DE LÍNEA SANT-NEJA	84
4.6.4.	FALLA TRIFÁSICA Y DISPARO DE LÍNEA SMAR-STOM	84
4.6.5.	FALLA TRIÁSICA Y DISPARO DE LÍNEA BERL-SMIG Y DISPARO DE 15SE-U1	85
4.6.6.	FALLA TRIFÁSICA EN BUS 115 kV DE SMIG Y DISPARO DE LÍNEAS BERL-SMIG Y SMIG-OZAT	85
4.6.7.	FALLA TRIFÁSICA EN LÍNEA SRAF-TECO Y DISPARO DE SRAF-TECO Y 15SE-U1	86
4.6.8.	FALLA TRIFÁSICA EN LÍNEA SRAF-15SE Y DISPARO DE LÍNEAS SRAF-TECO Y 15SE-SMIG.....	87
4.6.9.	FALLA TRIFÁSICA Y DISPARO LÍNEA SRAF-TECO, EN MANTENIMIENTO NCUS-ATEO	87
4.6.10.	FALLA TRIFÁSICA EN LÍNEA SANT-ATEO, DISPARO DE LÍNEAS SANT-NEJA Y ACAJ-ATEO.....	88
4.6.11.	FALLA TRIFÁSICA EN BUS 115 kV DE ATEO Y DISPARO DE LÍNEAS SANT-ATEO Y NCUS-ATEO.....	89
4.6.12.	FALLA TRIFÁSICA Y DISPARO DE LÍNEA SMAR-STOM Y DISPARO DE ACAJ-U5	89
4.6.13.	FALLA TRIFÁSICA EN LÍNEA NCUS-ATEO, DISPARO DE LÍNEAS ACAJ-ATEO Y SMAR-STOM.....	90
4.7.	VERIFICACIÓN DE PARÁMETROS CON ANÁLISIS EN EL DOMINIO DEL TIEMPO DEL EDCBV	90
4.7.1.	FALLA TRIFÁSICA Y DISPARO DE LÍNEA BERL-SMIG	91
4.7.2.	FALLA TRIFÁSICA Y DISPARO DE LÍNEA SRAF-TECO	91
4.7.3.	FALLA TRIFÁSICA Y DISPARO DE LÍNEA SANT-NEJA	92
4.7.4.	FALLA TRIFÁSICA Y DISPARO DE LÍNEA SMAR-STOM	92
4.7.5.	FALLA TRIÁSICA Y DISPARO DE LÍNEA NCUS-ATEO Y DISPARO	95
4.7.6.	FALLA TRIÁSICA Y DISPARO DE LÍNEA BERL-SMIG Y DISPARO DE 15SE-U1	95
4.7.7.	FALLA TRIFÁSICA EN BUS 115 kV DE SMIG Y DISPARO DE LÍNEAS BERL-SMIG Y SMIG-OZAT	96
4.7.8.	FALLA TRIFÁSICA EN LÍNEA SRAF-TECO Y DISPARO DE SRAF-TECO Y 15SE-U1	96
4.7.9.	FALLA TRIFÁSICA EN LÍNEA SRAF-15SE Y DISPARO DE LÍNEAS SRAF-TECO Y 15SE-SMIG.....	98
4.7.10.	FALLA TRIFÁSICA Y DISPARO LÍNEA SRAF-TECO, NCUS-ATEO.....	100
4.7.11.	FALLA TRIFÁSICA EN BUS 115 kV DE ATEO Y DISPARO DE LÍNEAS NCUS-ATEO Y SANT-ATEO.....	101
4.7.12.	FALLA TRIFÁSICA EN LÍNEA SANT-ATEO, DISPARO DE LÍNEAS SANT-NEJA Y ACAJ-ATEO.....	102
4.7.13.	FALLA TRIFÁSICA Y DISPARO DE LÍNEA SMAR-STOM Y DISPARO DE ACAJ-U5	102
4.7.14.	FALLA TRIFÁSICA EN LÍNEA NCUS-ATEO, DISPARO DE LÍNEAS ACAJ-ATEO Y SMAR-STOM.....	104
4.7.15.	FALLA TRIFÁSICA EN BUS 115 kV DE SMIG, DISPARO DE LÍNEAS 15SE-SMIG & BERL- SMIG.....	106
4.7.16.	FALLA TRIFÁSICA EN BUS 115 kV DE NCUS, DISPARO DE LÍNEAS SMAR-STOM & SANT-NEJA.....	108
4.7.17.	FALLA TRIFÁSICA EN BUS 115 kV DE OZAT, DISPARO DE LÍNEAS BERL-SMIG & SRAF-TECO.....	110
4.8.	VERIFICACIÓN DE RESERVA DE POTENCIA REACTIVA.....	111

1. ANÁLISIS DE FLUJO DE CARGA DEL CASO BASE

1.1. Caso sin Intercambio de potencia en las interconexiones

Archivo: MAR_MED08.sav

Utilizando las herramientas de análisis del PSS/E, se describe las condiciones de red del presente caso:

SISTEMA SALVADOREÑO DEMANDA MAXIMA MARZO 2008							AREA TOTALS		
ESTUDIO DE SEGURIDAD OPERATIVA-UT							IN MW/MVAR		
AREA	FROM GENERATION	TO LOAD	TO BUS SHUNT	TO LINE SHUNT	FROM CHARGING	TO NET INT	LOSSES	DESIRED NET INT	
2	889.6	870.0	0.0	0.0	0.0	0.2	19.4	0.0	
SALVADOR	328.1	282.6	-69.9	0.0	86.8	-2.6	204.8		

TRANSMISSION LINE LOADINGS ABOVE 100.0 % OF RATING SET A:

X-----FROM BUS-----X	X-----TO BUS-----X	CURRENT (MVA)
BUS NAME BSKV AREA	BUS NAME BSKV AREA	CKT LOADING RATING PERCENT
* NONE *		

TRANSFORMER LOADINGS ABOVE 100.0 % OF RATING SET A:

X-----FROM BUS-----X	X-----TO BUS-----X	MVA	MVA
BUS NAME BSKV AREA	BUS NAME BSKV AREA	CKT LOADING	RATING PERCENT
* NONE *			

BUSES WITH VOLTAGE GREATER THAN 1.0500:

X----- BUS -----X	AREA	V(PU)	V(KV)	X----- BUS -----X	AREA	V(PU)	V(KV)
* NONE *							

BUSES WITH VOLTAGE LESS THAN 0.9500:

X----- BUS -----X	AREA	V(PU)	V(KV)	X----- BUS -----X	AREA	V(PU)	V(KV)	
27421	NCUS-115	115	2 0.9432	108.47	27461	STOM-115	115 2 0.9441	108.57
27471	PEDR-115	115	2 0.9316	107.13				

Se indica que:

- La carga y la generación total en el área de El Salvador, corresponde a un día laboral de demanda media esperada de estación seca del mes de marzo;
- En condiciones normales no se presentan sobrecargas de líneas de transmisión;
- No hay transformadores sobrecargados respecto al “rate A” (ajustado al 90% de la capacidad máxima del transformador);
- No hay violaciones por alto voltaje (>1.05 p.u.);
- En condiciones normales, no existen condiciones de bajo voltaje (<0.95 p.u.) excepto en las subestaciones Nuevo Cuscatlán, Santo Tomás y Pedregal. Ver la figura 1.

Figura 1 - Diagrama unifilar de la red del caso intercambio mínimo del escenario de demanda media de marzo.

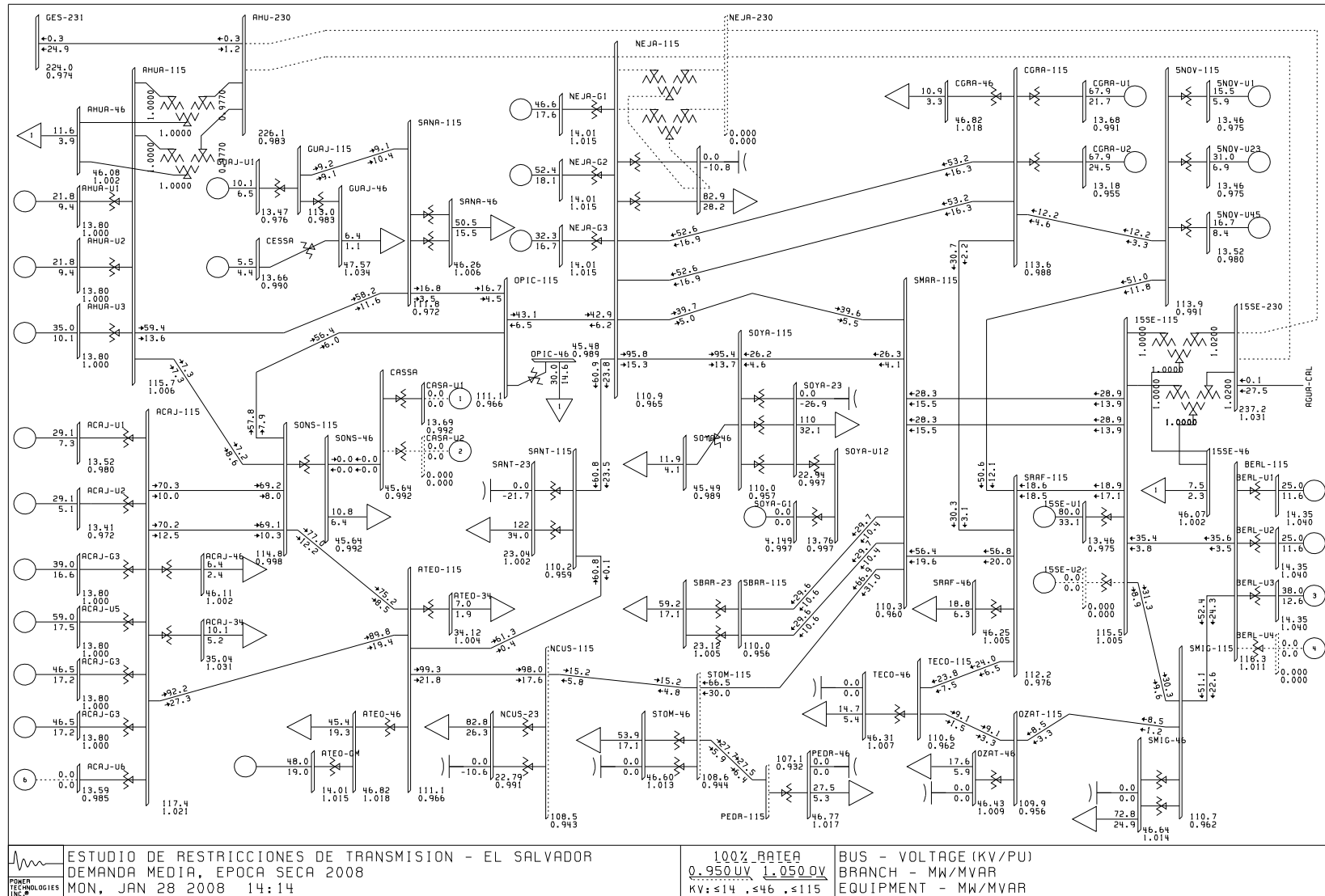

2. IDENTIFICACIÓN DE LAS AREA LOCALES

A continuación se obtendrá el factor de efectividad a todos los nodos de transmisión, para lo cual se calcula las curvas Q-V con y sin compensación de reactivos de 50 MVAR en dichos nodos; todas las cargas estarán convertidas y los cambiadores de taps de los transformadores permanecerán fijos.

2.1. Curvas Q-V con y sin compensación:

5 de Noviembre, sc, $Q_{min} = -213$ Mvars
 $V_{sc} = 0.992$

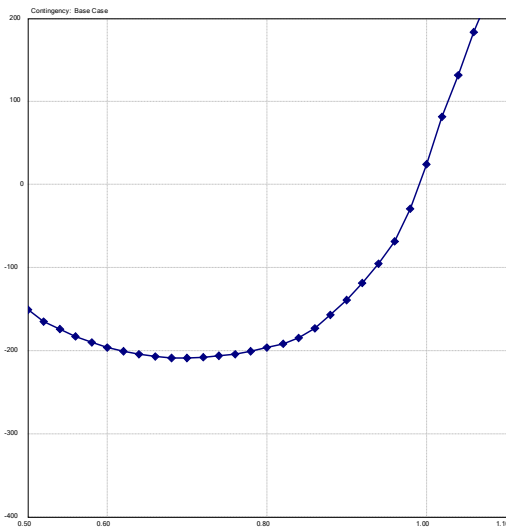

cc, $Q_{min} = -238$ Mvars
 $V_{cc} = 1.009$

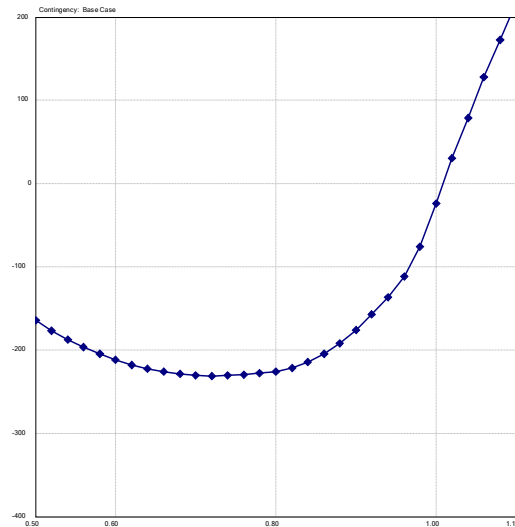

Guajoyo, sc, $Q_{min} = -149$ Mvars
 $V_{sc} = 0.984$

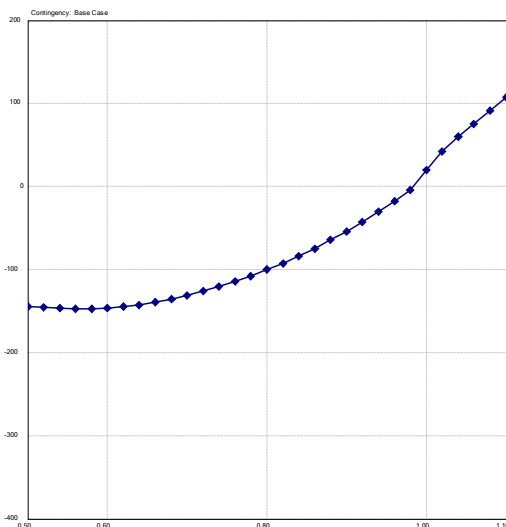

cc, $Q_{min} = -166$ Mvars
 $V_{cc} = 1.032$

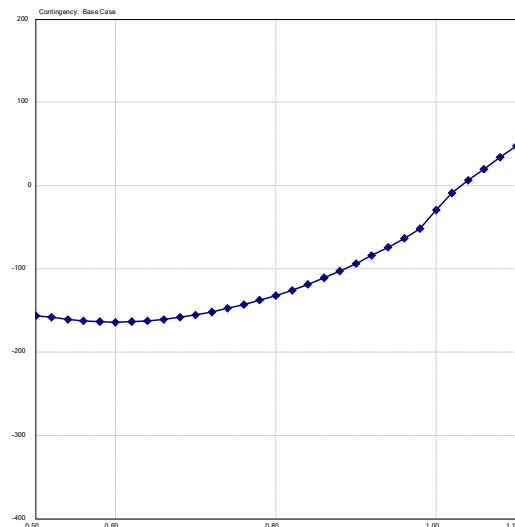

Acajutla, sc, $Q_{min} = -229$ Mvars
 $V_{sc} = 1.021$

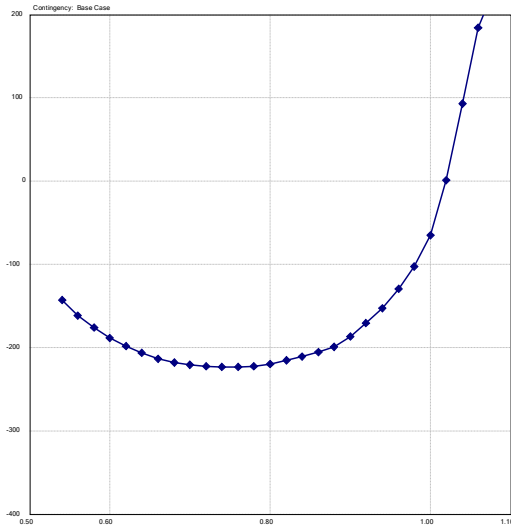

cc, $Q_{min} = -256$ Mvars
 $V_{cc} = 1.033$

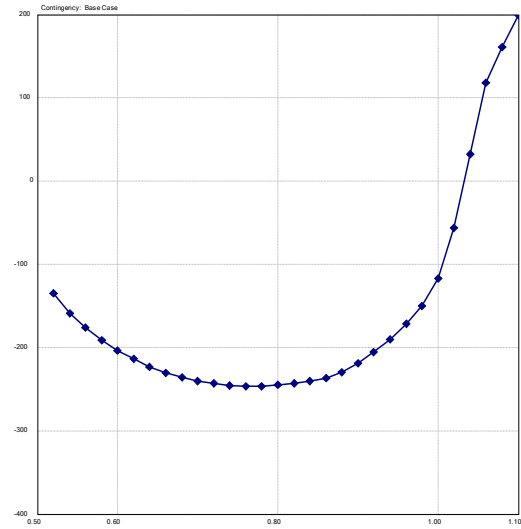

Ahuachapán, $Q_{min} = -314$ Mvars
 $V_{sc} = 1.006$

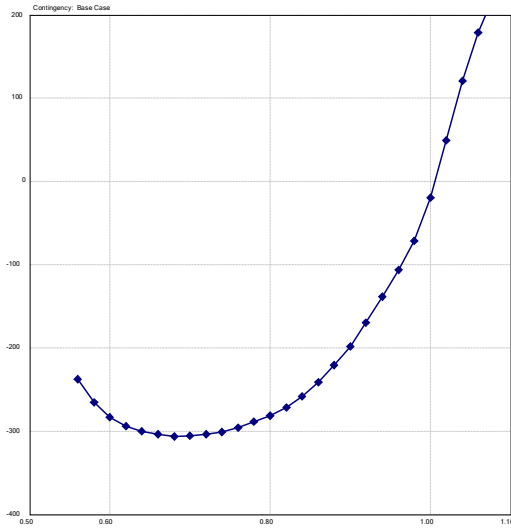

cc, $Q_{min} = -337$ Mvars
 $V_{cc} = 1.021$

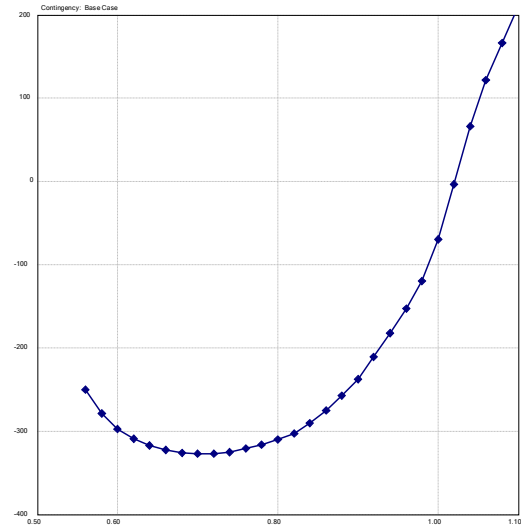

Cerrón Grande, sc, $Q_{min} = -227$ Mvars
 $V_{sc} = 0.989$

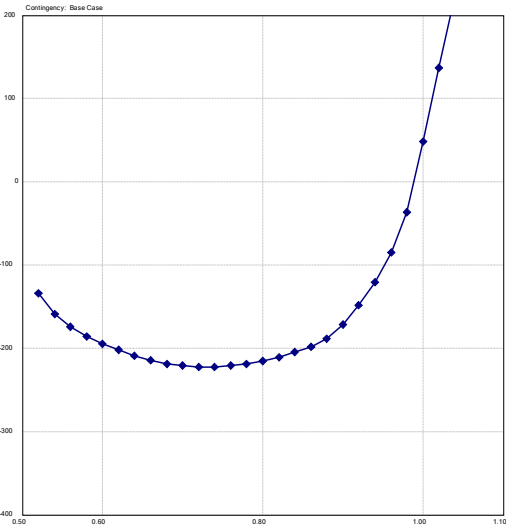

cc, $Q_{min} = -254$ Mvars
 $V_{cc} = 1.001$

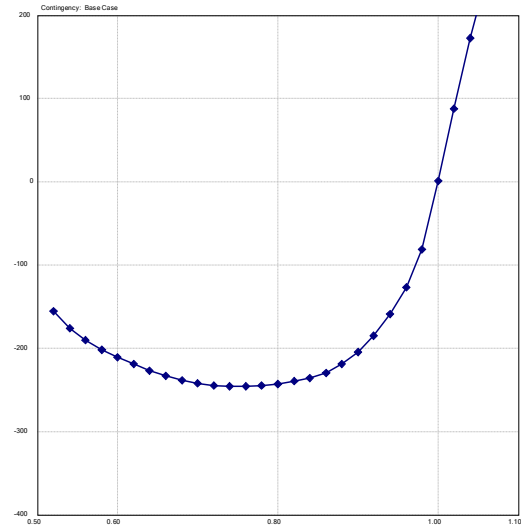

15 de Septiembre, sc, Qmin = -274 Mvars

Vsc = 1.006

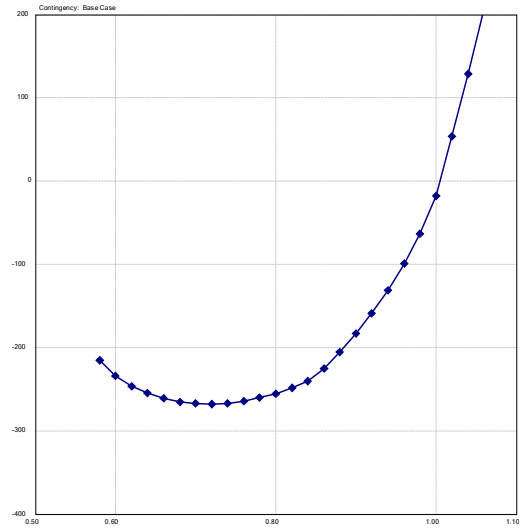

Berlín, sc, Qmin = -223 Mvars

Vsc = 1.012

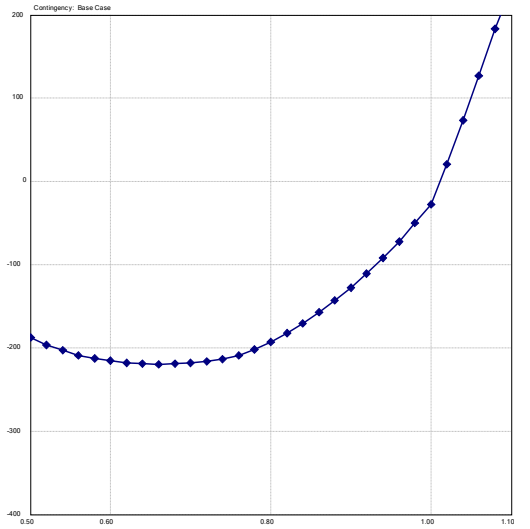

Soyapango, sc, Qmin = -227 Mvars

Vsc = 0.959

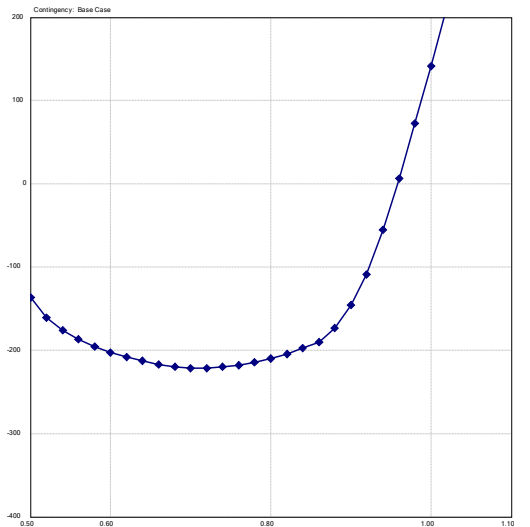

cc, Qmin = -300 Mvars

Vcc = 1.020

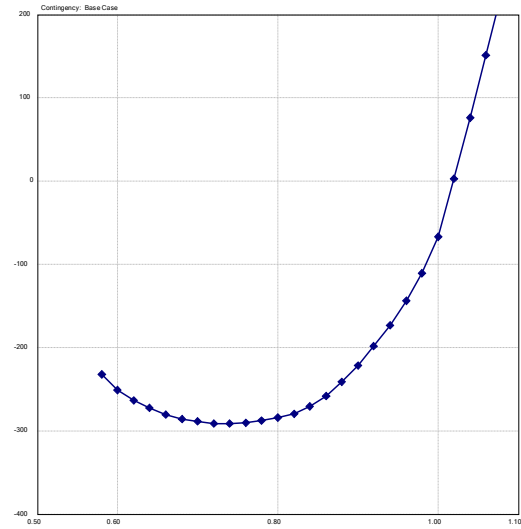

cc, Qmin = -246 Mvars

Vcc = 1.033

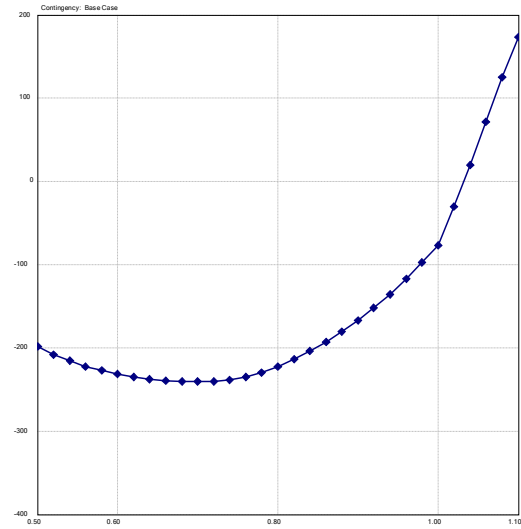

cc, Qmin = -253 Mvars

Vcc = 0.973

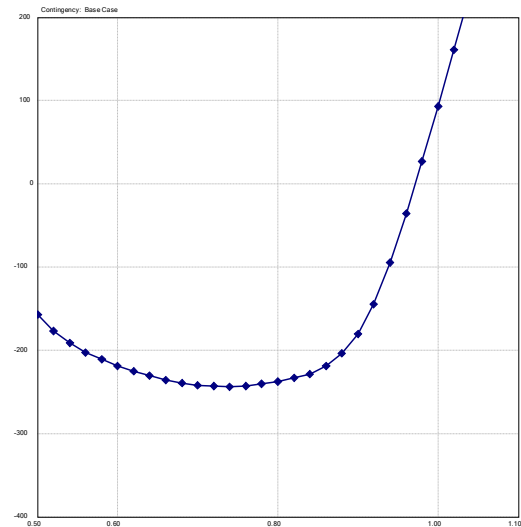

San Rafael, sc, Qmin = -233 Mvars
Vsc = 0.977

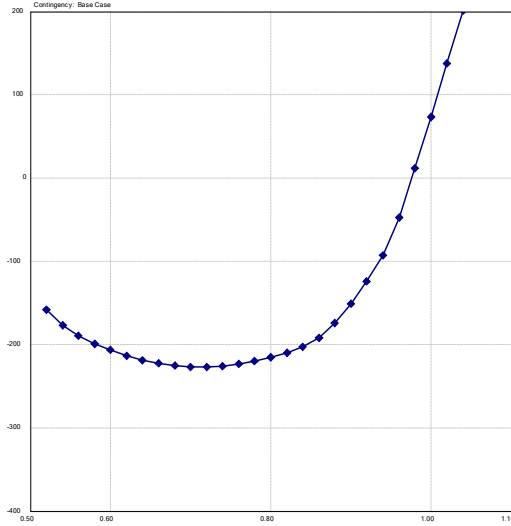

cc, Qmin = -259 Mvars
Vcc = 0.993

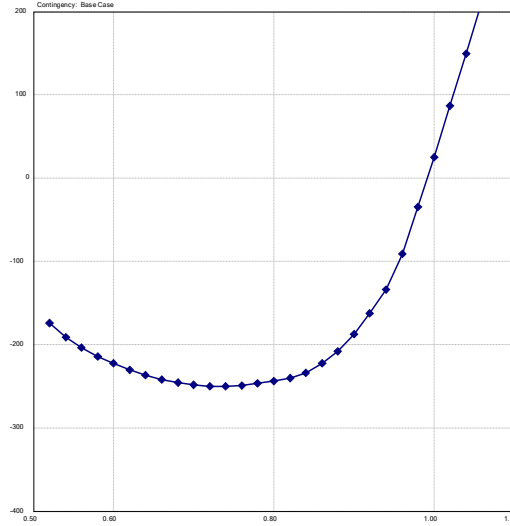

San Miguel, sc, Qmin = -179 Mvars
Vsc = 0.963

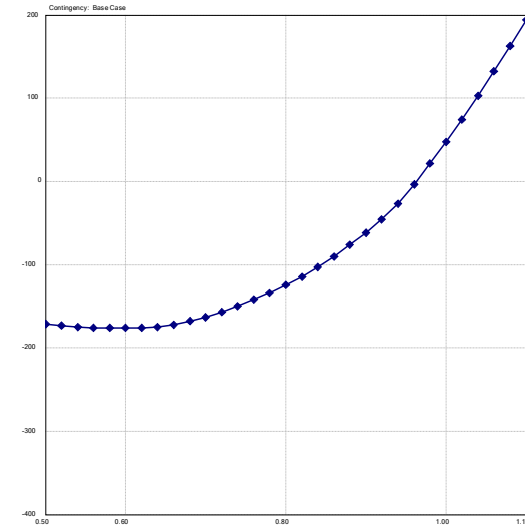

cc; Qmin = -197 Mvars
Vcc = 1.003

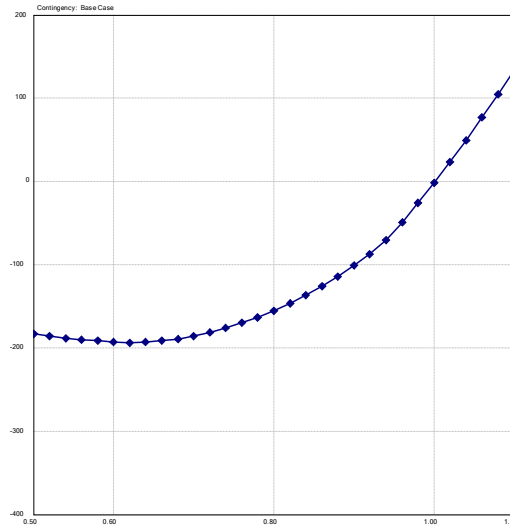

Santa Ana, Qmin = -222 Mvars
Vsc = 0.973

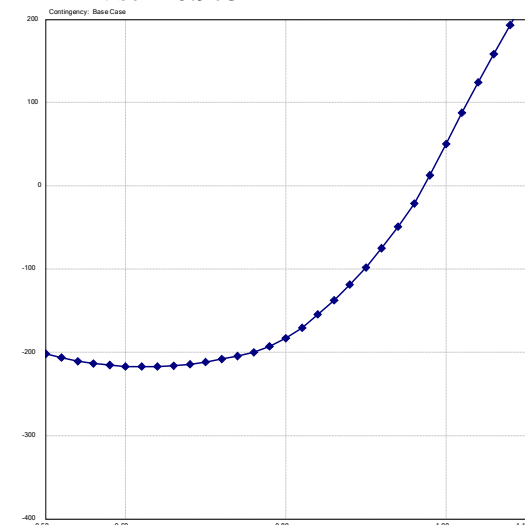

cc, Qmin = -243 Mvars
Vcc = 1.000

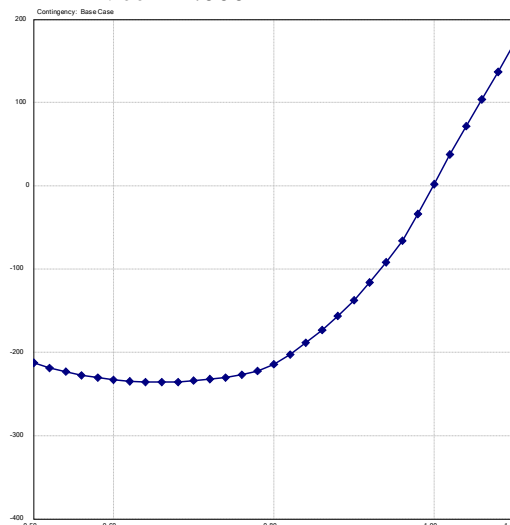

San Antonio Abad, sc, Qmin = -228 Mvars
Vsc = 0.960

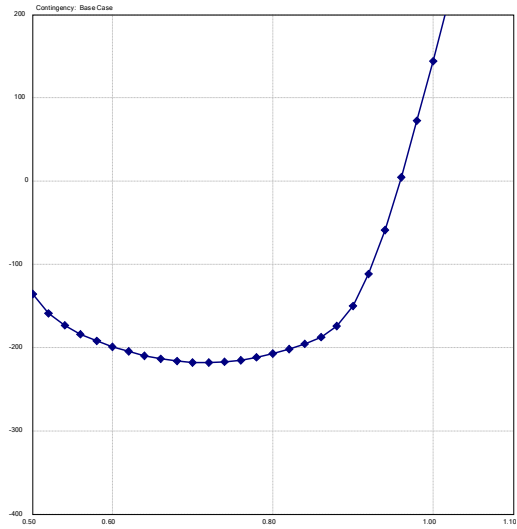

cc, Qmin = -254 Mvars
Vcc = 0.974

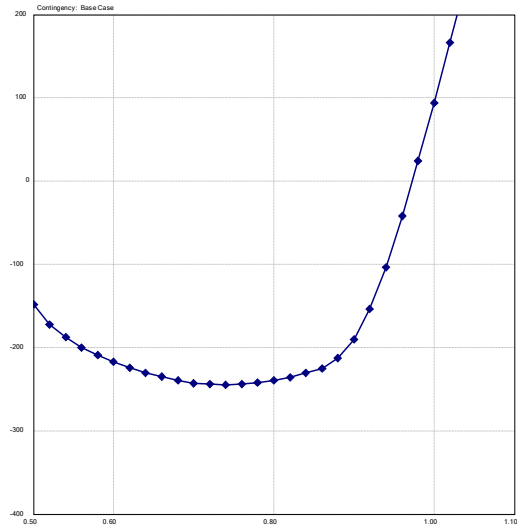

Nejapa, sc, Qmin = -241 Mvars
Vsc = 0.966

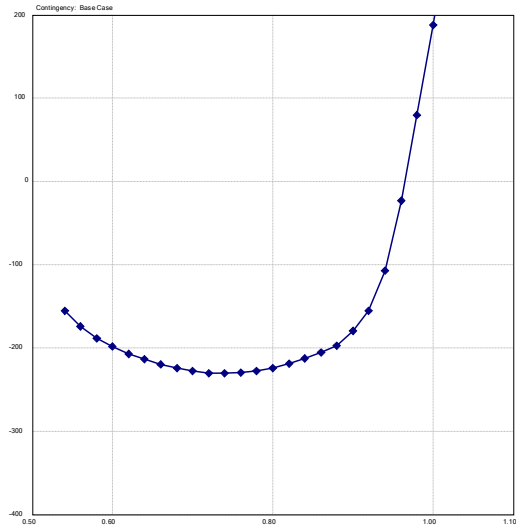

cc, Qmin = -269 Mvars
Vcc = 0.975

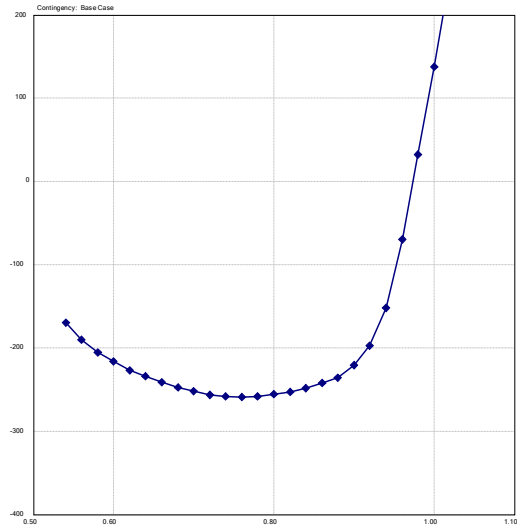

Opico, sc, Qmin = -236 Mvars
Vsc = 0.967

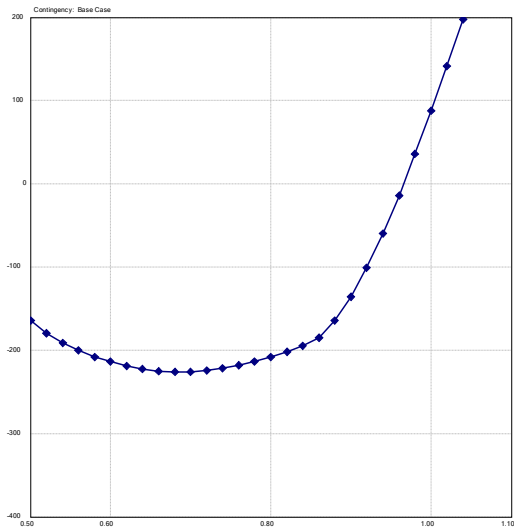

cc, Qmin = -260 Mvars
Vcc = 0.987

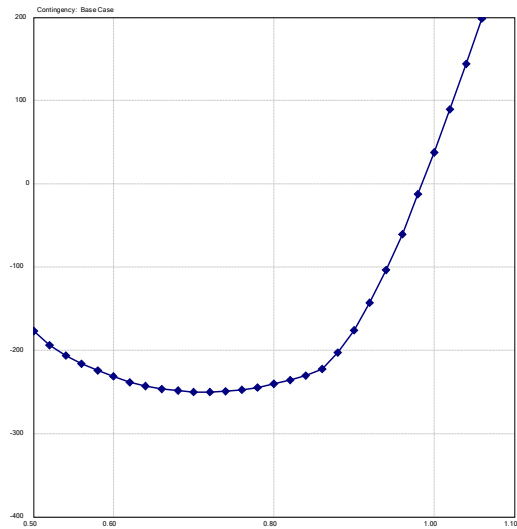

Tecoluca, sc, $Q_{min} = -168$ Mvars
 $V_{sc} = 0.963$

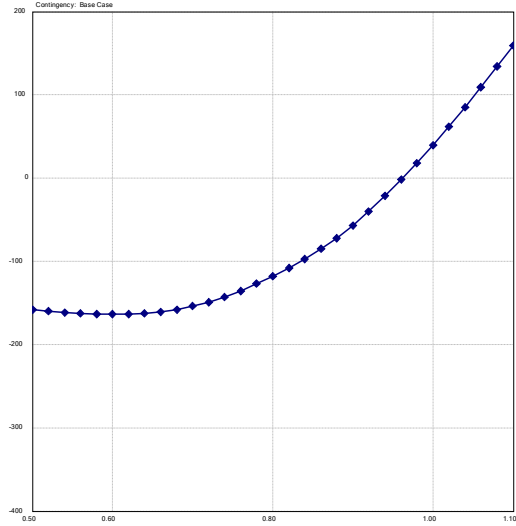

cc, $Q_{min} = -187$ Mvars
 $V_{cc} = 1.011$

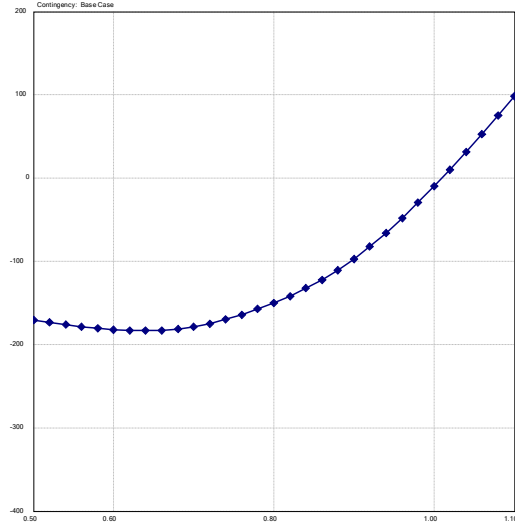

Ozatlán, sc, $Q_{min} = -145$ Mvars
 $V_{sc} = 0.957$

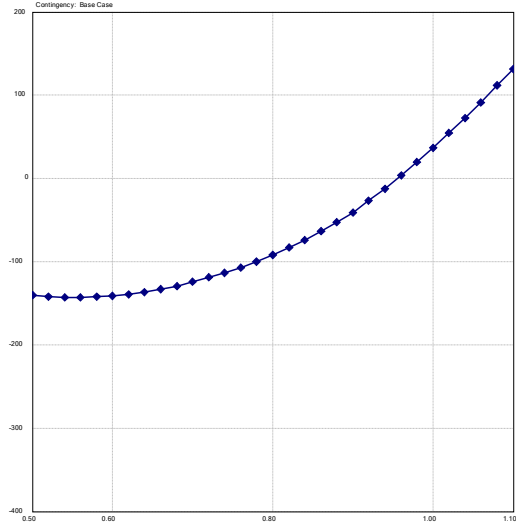

cc; $Q_{min} = -161$ Mvars
 $V_{cc} = 1.018$

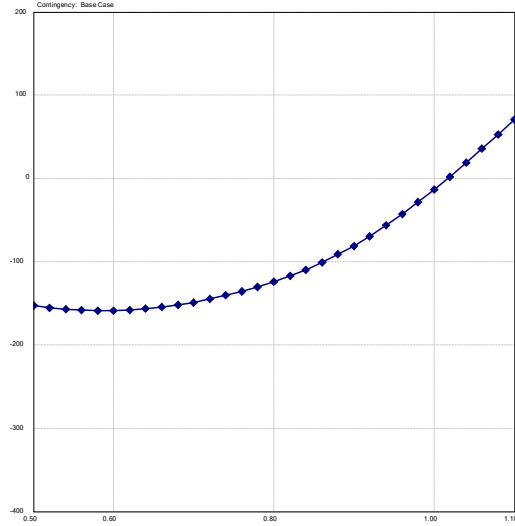

Sonsonate, sc, $Q_{min} = -250$ Mvars
 $V_{sc} = 0.999$

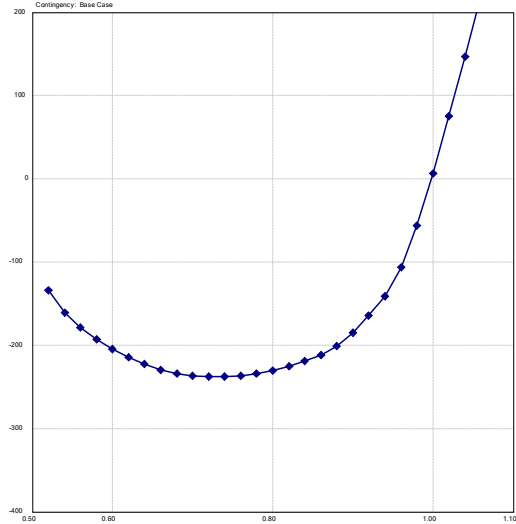

cc, $Q_{min} = -277$ Mvars
 $V_{cc} = 1.014$

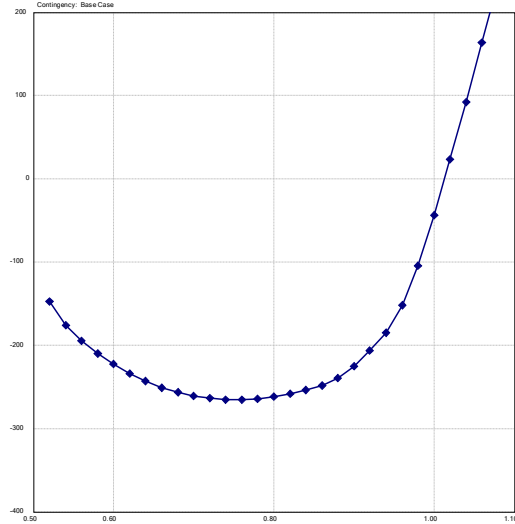

Nuevo Cuscatlán, sc, $Q_{min} = -198$ Mvars

$V_{sc} = 0.945$

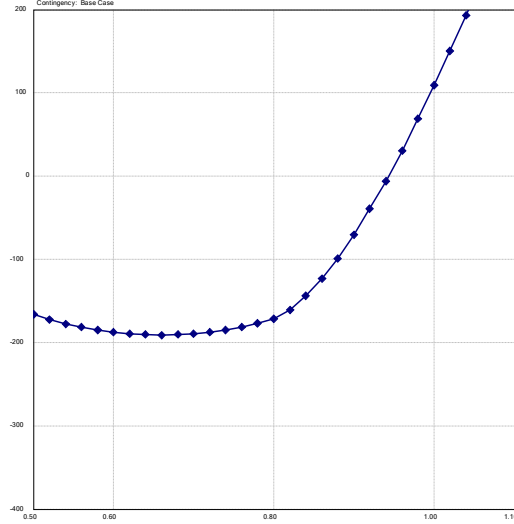

cc; $Q_{min} = -221$ Mvars

$V_{cc} = 0.970$

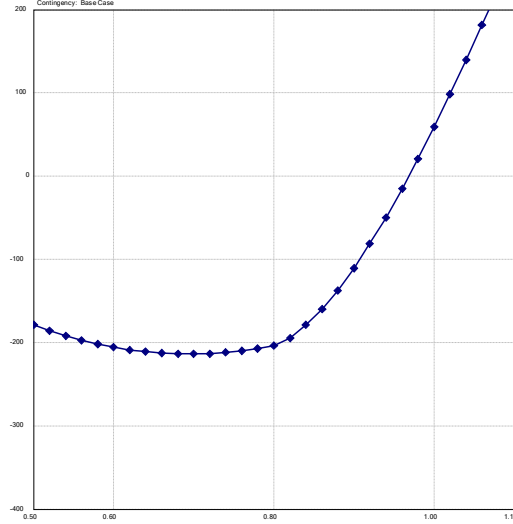

San Martín, sc, $Q_{min} = -238$ Mvars

$V_{sc} = 0.961$

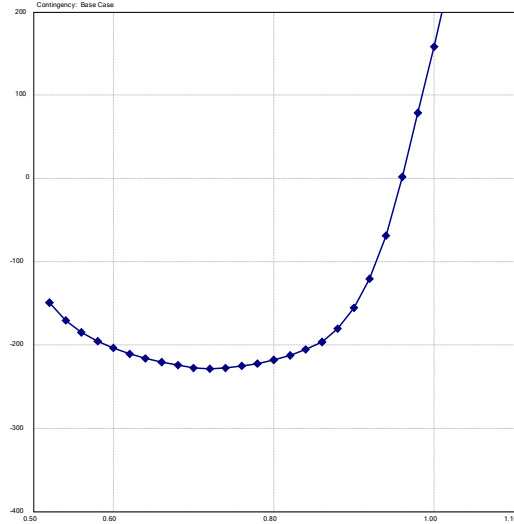

cc; $Q_{min} = -265$ Mvars

$V_{cc} = 0.974$

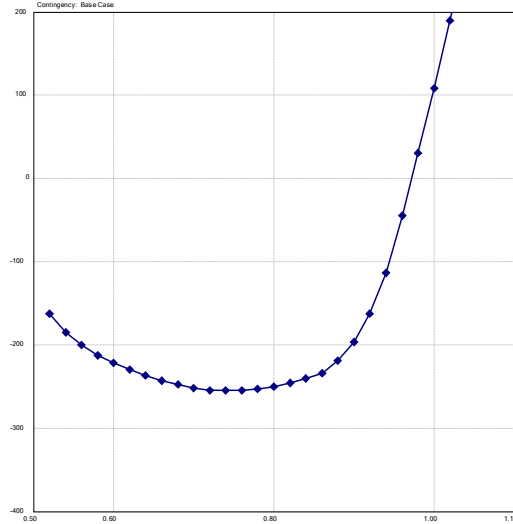

Ateos, sc, $Q_{min} = -226$ Mvars

$V_{sc} = 0.968$

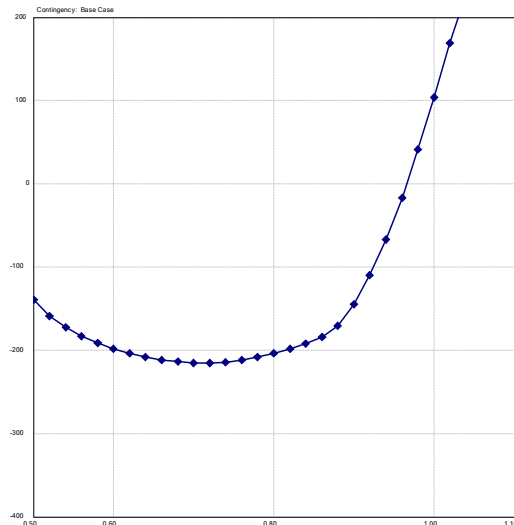

cc, $Q_{min} = -251$ Mvars

$V_{cc} = 0.984$

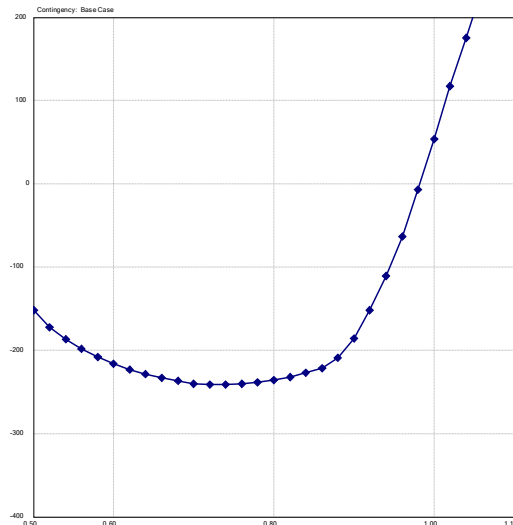

San Bartolo, sc, $Q_{min} = -228$ Mvars
 $V_{sc} = 0.958$

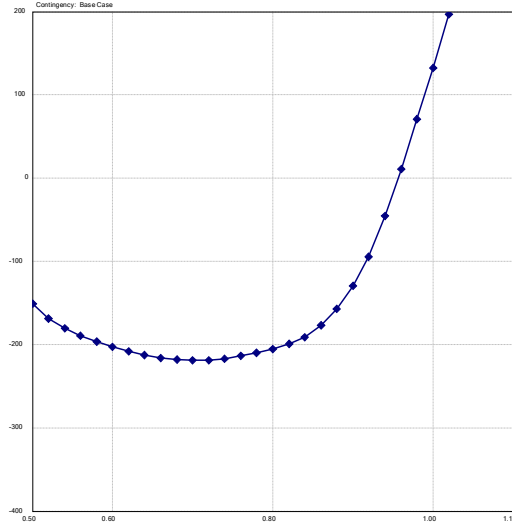

cc; $Q_{min} = -254$ Mvars
 $V_{cc} = 0.974$

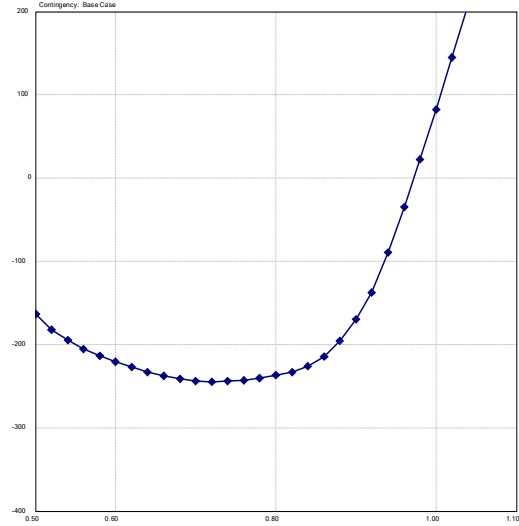

Santo Tomás, sc, $Q_{min} = -209$ Mvars
 $V_{sc} = 0.946$

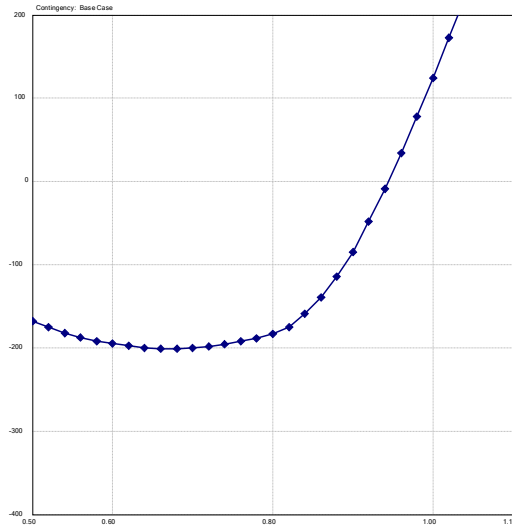

cc, $Q_{min} = -233$ Mvars
 $V_{cc} = 0.968$

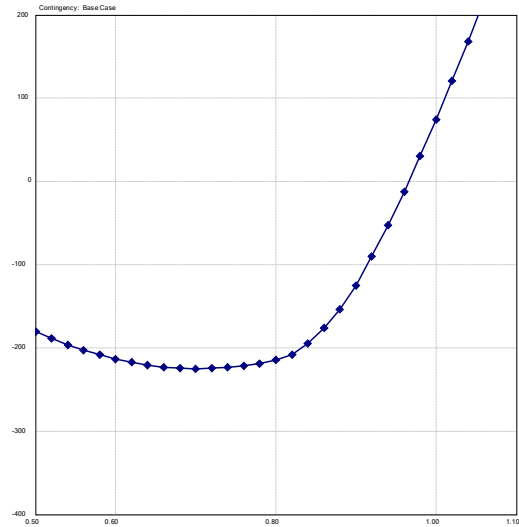

El Pedregal, sc, $Q_{min} = -139$ Mvars
 $V_{sc} = 0.934$

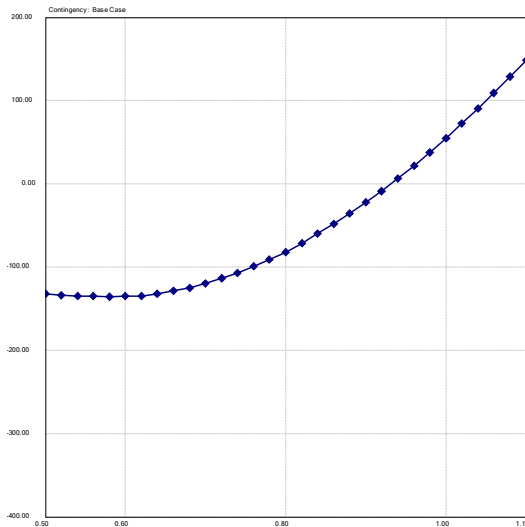

cc; $Q_{min} = -157$ Mvars
 $V_{cc} = 0.996$

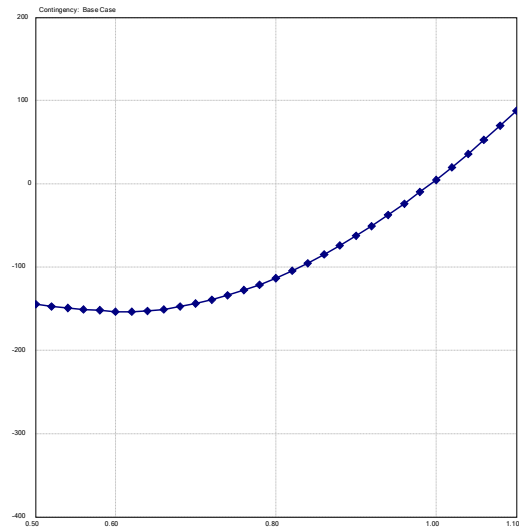

Un resumen de los resultados se presenta a continuación, junto al cálculo del factor de efectividad:

Demanda media			Cálculo del factor de sensibilidad			Cálculo del factor de efectividad		
Mes de marzo			voltaje sin comp	voltaje con comp	dV/dQ*10 ³	margen Q sin comp	margen Q con comp	Factor de efectividad
Sub	nodo	Voltaje						
PEDR	27471	115	0.934	0.996	1.24	139	157	11.5%
OZAT	27401	115	0.957	1.018	1.22	145	161	9.9%
GUAJ	27111	115	0.984	1.032	0.96	149	166	10.2%
TECO	27391	115	0.963	1.011	0.96	168	187	10.2%
SMIG	27341	115	0.963	1.003	0.8	179	197	9.1%
SANA	27351	115	0.973	1	0.54	222	243	8.6%
NCUS	27421	115	0.945	0.97	0.5	198	221	10.4%
STOM	27461	115	0.946	0.968	0.44	209	233	10.3%
BERL	27211	115	1.012	1.033	0.42	223	246	9.3%
OPIC	27381	115	0.967	0.987	0.4	236	260	9.2%
5NOV	27101	115	0.992	1.009	0.34	213	238	10.5%
SRAF	27321	115	0.977	0.993	0.32	233	259	10.0%
ATEO	27441	115	0.968	0.984	0.32	226	251	10.0%
SBAR	27451	115	0.958	0.974	0.32	228	254	10.2%
SONS	27411	115	0.999	1.014	0.3	250	277	9.7%
AHUA	27161	115	1.006	1.021	0.3	314	337	6.8%
15SE	27181	115	1.006	1.02	0.28	274	300	8.7%
SOYA	27301	115	0.959	0.973	0.28	227	253	10.3%
SANT	27361	115	0.96	0.974	0.28	228	254	10.2%
SMAR	27431	115	0.961	0.974	0.26	238	265	10.2%
ACAJ	27131	115	1.021	1.033	0.24	229	256	10.5%
CGRA	27171	115	0.989	1.001	0.24	227	254	10.6%
NEJA	27371	115	0.966	0.975	0.18	241	269	10.4%

Una gráfica de los resultados ordenado por factores de efectividad se muestra a continuación:

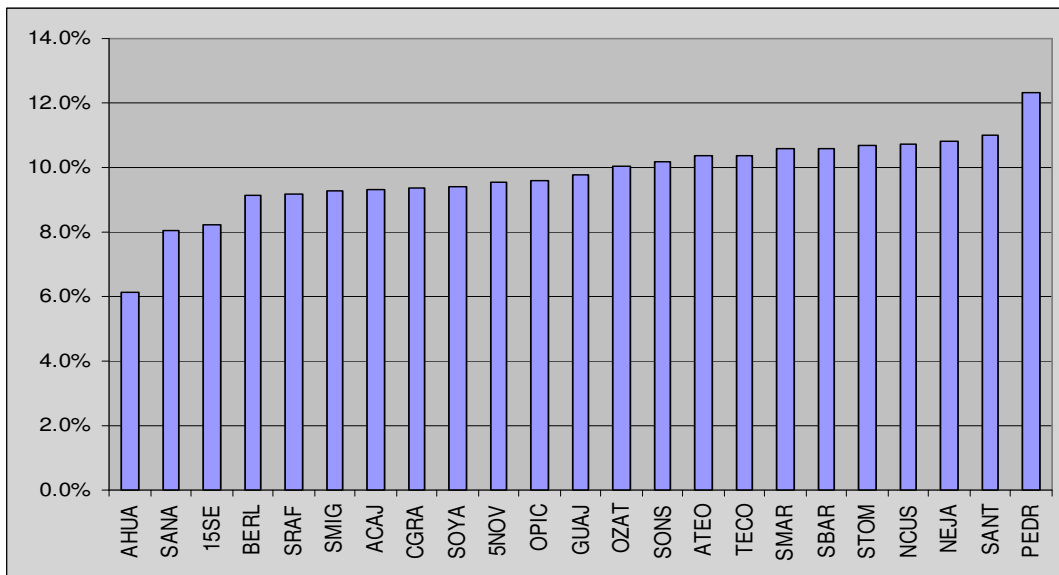

Y otra gráfica de los resultados ordenado por factores de sensibilidad se muestra a continuación:

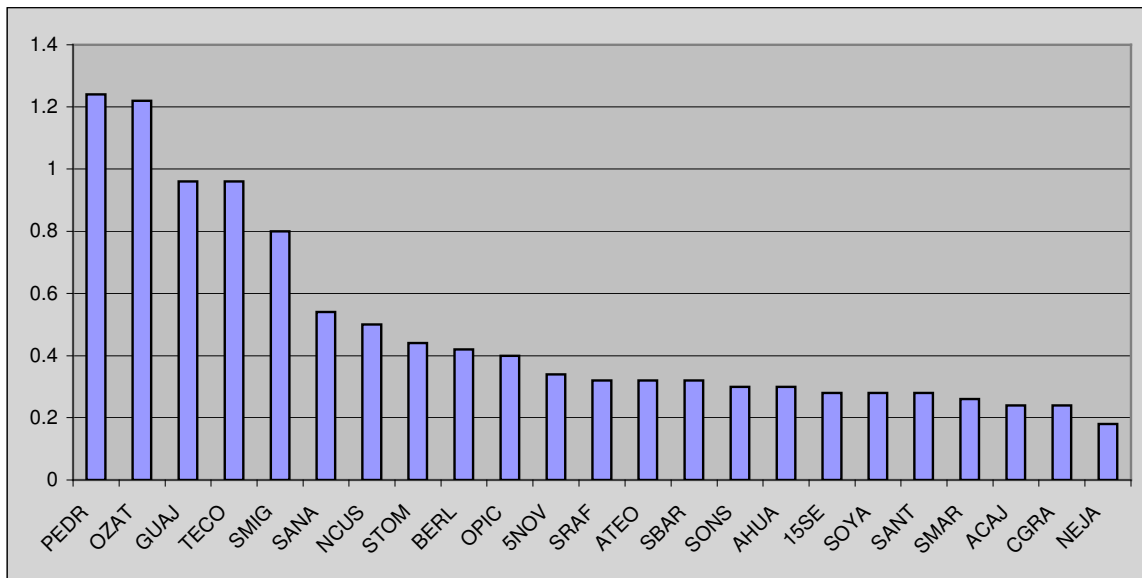

Se indica de mayor a menor, la sensibilidad de variar el voltaje respecto a una inyección de reactivo del nodo. Nótese que Guajoyo aparece con un valor relativamente grande de sensibilidad porque se encuentra en circuito radial. Hay una indicación de área local formada por los nodos PEDR, OZAT, TECO y SMIG.

3. ANÁLISIS DE CONTINGENCIAS DE LA RED DE TRANSMISIÓN

En el presente estudio, se simularán disparos simples y múltiples de todos los elementos de la red nacional.

A continuación se probarán los diferentes escenarios de carga e intercambio que fueron recomendados en el estudio Evaluación de Restricciones de Transmisión 2008.

Los casos que serán analizados son los siguientes:

- Caso A: cero intercambio de potencia en las interconexiones
- Caso B: máxima transferencia Guatemala --> El Salvador 40 MW
- Caso C: máxima transferencia El Salvador --> Guatemala 106 MW
- Caso D: máxima transferencia Honduras --> El Salvador 80¹ MW
- Caso E: máximo transferencia El Salvador --> Honduras 91 MW

3.1. Contingencias N-1

¹ HE + 15SE < 180 MW

3.1.1. Caso A: Cero intercambio de potencia en las interconexiones (caso base)

Archivo: MM_0.raw (versión 26 convertida de MAR_MED08.sav)

Utilizando el programa TPLAN en el modo de “valoración determinística” del análisis de contingencias, se obtienen los siguientes resultados²:

Cuadro 1 – Porcentaje de carga de líneas de transmisión sobrecargadas y voltaje en p.u. de barras con violaciones de voltaje (banda de emergencia).

Contingencia			Línea Sobrecargada					Barras con Violaciones de Voltaje				
Barra Desde	Barra Hacia	ckt	GUAT-AHUA	AHUA-SANA	AHUA-SONS	SONS-ATEO	15SE-SMIG	SMIG -115	TECO -115	NCUS -115	STOM -115	PEDR -115
ACAJ-115	ATEO-115	1				106%						
BERL-115	SMIG-115	1					0.893					
SRAF-115	TECO-115	1						0.897				
NCUS-115	ATEO-115	1							0.888			0.896
SMAR-115	STOM-115	1							0.877	0.855		0.841

Los resultados indican lo siguiente:

- El TPLAN realizó 56 contingencias de líneas de transmisión.
- Se presenta un caso de sobrecarga en líneas de transmisión
- No hay casos de colapsos de voltaje, ni de no convergencia en la solución de flujo de potencia.
- 4 casos de contingencias presentan violación del límite inferior de la banda de emergencia de voltaje (0.90 p.u.).

Acciones Correctivas para eliminar las violaciones anteriores:

- Reducción de la generación de Acajutla a 233 MW de generación máxima
- Compensación capacitiva en los siguientes nodos:
 - Tecoluca con 10.8 Mvar
 - Santo Tomás con 32.4 Mvar
- Corte de carga por bajo voltaje en los nodos anteriores.

3.1.2. Caso B: Máxima transferencia Guatemala --> El Salvador 40 MW.

Archivo: MM_GE40.raw (versión 26 convertida de MM_GE40.sav)

Utilizando el programa TPLAN en el modo de “valoración determinística” del análisis de contingencias, se obtienen los siguientes resultados³:

Cuadro 2 – Porcentaje de carga de líneas de transmisión sobrecargadas y voltaje en pu de barras con violaciones de voltaje (banda de emergencia).

² Tomado del estudio de Evaluación de Restricciones de Transmisión 2008

³ Tomado del estudio de Evaluación de Restricciones de Transmisión 2008

Contingencia			Línea Sobrecargada					Barras con Violaciones de Voltaje					
Barra Desde	Barra Hacia	ckt	AHUA-SANA	AHUA-SONS	SONS-ATEO	SANA-OPIC	15SE-SMIG	SMIG-115	TECO-115	SANT-115	NCUS-115	STOM-115	PEDR-115
ACAJ-115	ATEO-115	1			104%								
BERL-115	SMIG-115	1						0.891					
SRAF-115	TECO-115	1							0.896				
SANT-115	NEJA-115	1								0.898			
NCUS-115	ATEO-115	1									0.886		0.893
SMAR-115	STOM-115	1									0.871	0.848	0.834

Los resultados indican lo siguiente:

- El TPLAN realizó 56 contingencias de líneas de transmisión.
- Se presentó un caso de sobrecarga en líneas de transmisión.
- 5 casos de contingencias presentan violación del límite inferior de la banda de emergencia de voltaje (0.90 p.u.).
- No hay casos de colapsos de voltaje, ni de no-convergencia en la solución de flujo de potencia.

Las acciones correctivas para eliminar las violaciones a los parámetros de calidad anteriores son:

- Reducción de la generación de Acajutla a 199 MW.
- Compensación capacitiva en los siguientes nodos:
 - Tecoluca con 10.8 Mvar
 - Santo Tomás con 32.4 Mvar
 - Pedregal con 10.8 Mvar
- Corte de carga por bajo voltaje en los nodos anteriores.

3.1.3. Caso C: Máxima transferencia El Salvador --> Guatemala 106 MW

Archivo: MM_EG106.raw (versión 26 convertida de MM_EG106.sav)

Utilizando el programa TPLAN en el modo de “valoración determinística” del análisis de contingencias, se obtienen los siguientes resultados⁴:

Cuadro 3 – Porcentaje de carga de líneas de transmisión sobrecargadas y voltaje en pu de barras con violaciones de voltaje (banda de emergencia).

Contingencia			Barras con Violaciones de Voltaje				
Barra Desde	Barra Hacia	ckt	SMIG-115	SANT-115	NCUS-115	STOM-115	PEDR-115
NCUS-115	ATEO-115	1			0.895		
SMAR-115	STOM-115	1			0.881	0.859	0.845

Los resultados indican lo siguiente:

⁴ Tomado del estudio de Evaluación de Restricciones de Transmisión 2008

- El TPLAN realizó 57 contingencias de líneas de transmisión.
- No se presentan casos de sobrecarga en líneas de transmisión.
- Dos casos de contingencias presentan violación del límite inferior de la banda de emergencia de voltaje (0.90 p.u.).
- No hay casos de colapsos de voltaje, ni de no-convergencia en la solución de flujo de potencia.

Acciones Correctivas para eliminar las violaciones anteriores:

- Compensación capacitiva en los siguientes nodos:
 - Santo Tomás con 21.6Mvar
 - Pedregal con 10.8 Mvar
- Corte de carga por bajo voltaje en los nodos anteriores.

3.1.4. Caso D: Máxima transferencia Honduras --> El Salvador 80 MW

Archivo: MX_HE80.raw (versión 26 convertida de MX_HE80.sav)

Utilizando el programa TPLAN en el modo de “valoración determinística” del análisis de contingencias, se obtienen los siguientes resultados⁵:

Cuadro 4 – Porcentaje de carga de líneas de transmisión sobrecargadas y voltaje en p.u. de barras con violaciones de voltaje (banda de emergencia).

Equipo	Barras con Violaciones de Voltaje				
	SMIG -115	SANT -115	NCUS -115	STOM -115	PEDR -115
Línea BERL-SMIG	0.889				
Línea NCUS-ATEO-1			0.883		0.891
Línea SMAR-STOM-1			0.876	0.854	0.840

Los resultados indican lo siguiente:

- El TPLAN realizó 23 contingencias más críticas.
- Cuatro casos de contingencias presentan violación del límite inferior de la banda de emergencia de voltaje (0.90 p.u.).
- No hay casos de no convergencia en la solución de flujo de potencia

Acciones Correctivas para eliminar las violaciones anteriores:

- Compensación capacitiva en los siguientes nodos:
 - San Miguel con 10.8 Mvar ó Tecoluca 10.8 Mvar
 - Santo Tomás con 21.6 Mvar
 - Pedregal con 10.8 Mvar
- Corte de carga por bajo voltaje en los nodos anteriores.

⁵ Tomado del estudio de Evaluación de Restricciones de Transmisión 2008

- La forma segura de importar desde Honduras, es tal que se sustituya generación de la zona oriental y se encuentre en línea al menos uno de los generadores de 15 de Septiembre.
- Ninguna importación desde Honduras debería desplazar generación de la zona occidental.

3.1.5. Caso E: Máxima transferencia El Salvador--> Honduras 91 MW

Archivo: MX_EH91.raw (versión 26 convertida de MX_EH91.sav)

Utilizando el programa TPLAN en el modo de “valoración determinística” del análisis de contingencias, se obtienen los siguientes resultados:

Cuadro 6 – Porcentaje de carga de líneas de transmisión sobrecargadas y voltaje en p.u. de barras con violaciones de voltaje (banda de emergencia).

Contingencia			Barras con Violaciones de Voltaje				
Barra Desde	Barra Hacia	ckt	SMIG -115	SANT -115	NCUS -115	STOM -115	PEDR -115
NCUS-115	ATEO-115	1			0.894		
SMAR-115	STOM-115	1			0.879	0.858	0.843

Los resultados indican lo siguiente:

- El TPLAN realizó 57 contingencias de líneas de transmisión.
- Se presentan un caso de sobrecarga en líneas de transmisión.
- Dos casos de contingencias presentan violación del límite inferior de la banda de emergencia de voltaje (0.90 p.u.).
- No hay casos de colapsos de voltaje, ni de no convergencia en la solución de flujo de potencia.

Acciones Correctivas para eliminar las violaciones anteriores:

- Compensación capacitiva en los siguientes nodos:
 - Santo Tomás con 21.6 Mvar
 - El Pedregal con 10.8 Mvar
- Corte de carga por bajo voltaje en los nodos anteriores.
- La forma segura de exportar energía a Honduras consistiría en generar “el exceso de generación” en la zona oriental del país.

3.2. Contingencias N-2

3.2.1. Caso A: Cero intercambio de potencia en las interconexiones (caso base)

Archivo: MM_08.raw (versión 26 convertida de MAR_MED08.sav)

Con el objeto de evitar el analizar los casos menos críticos, primeramente se hizo un análisis de la cantidad de casos de contingencias N-2 se producen en función del límites inferior de voltaje para el cual se considera un abatimiento del voltaje extremo:

Límite inferior de voltaje en nodos (p.u.)	Número de casos con violación del límite inferior de voltaje	Número de casos con colapso de voltaje o de No-convergencia
0.90	258	2
0.89	145	2
0.88	82	2
0.87	72	2
0.86	69	2
0.85	69	2
0.84	30	2
0.837	13	2
0.83	6	2

Del cuadro anterior, se concluye que hay dos caso de “colapso de voltaje”, son una constante en todos los escenarios posibles; y que además, como punto de partida, se analizarán los 13 casos de bajo voltaje con respecto a la violación de límite inferior de 0.837 p.u. de voltaje, cuyos resultados se muestran a continuación:

```

*** CONTINGENCY RESULTS SUMMARY ***

TOTAL NO. OF CONTINGENCIES TESTED      =    757
I.   CONVERGED CONTINGENCIES            =    755
II.  VOLTAGE COLLAPSE CONTINGENCIES     =     2
III. NOT CONVERGED CONTINGENCIES        =     0

*** FAILURE SUMMARY ***

FAILURE CRITERIA                        NO. OF  WORST  CASE
-----                                FAILURES INDEX  VALUE
-----                                -----  ----  -----
I.   CONVERGED ( 755 CONTINGENCIES) :

AT LEAST ( 1) BUSES PER ISLAND          0        0 ( 0)
OVERLOAD ABOVE (1.00) PU OF RATING (B)  64       285 ( 1.71)
CHANGE IN FLOW ABOVE (999.0%)           0        0 ( 0.0)
BUS VOLTAGE ABOVE ( 1.10) P.U.          0        0 ( 0.00)
BUS VOLTAGE BELOW ( 0.84) P.U.          13       333 ( 0.66)
SUBTOTAL                                74
II.  VOLTAGE COLLAPSE:                   2
III. NOT-CONVERGED (MM > 0.10)           0

TOTAL FAILED CONTINGENCIES :              76
(OFT OF 757 CONTINGENCIES TESTED)

```

Los resultados indican lo siguiente:

- El TPLAN realizó 757 contingencias más severas de líneas de transmisión y de generación.
- Hay 13 casos críticos de contingencias que presentan violación del límite inferior de voltaje (0.837 p.u.).

- Hay 64 casos de violación por sobrecarga de líneas de transmisión, los cuales no son objeto del presente estudio.
- Hay 2 casos de colapso de voltaje en la solución de flujo de potencia.

Un resumen detallado de los casos de bajo voltaje se muestra a continuación:

```

SUMMARY OF FAILED CONTINGENCIES
(OVLD> 1.00 RATEB, V.COLLAPSE<0.50, VOLT>1.10, VOLT<0.84, BUSES/ISLD>= 1)
-----
CONTINGENCY 43 : BRANCH 1090 ++UNIT 338

----- POST-CONTINGENCY RESULTS -----
SOLN OVERLOAD DELT-FLOW HIGH-VOLT LOW-VOLT SWING GEN ITER MM
- 0-0.00 0- 0.0 0-0.00 1-0.83 ( 57, 13) 4 0.08

OUTAGES FROM BUS TO BUS ID BASE CASE RATING-B P.U.-B
27431 SMAR-115 115 27461 STOM-115 115 1 77 266 0.29
21441 ATEO-GM 13.8 1 16 17

* AREA 2 * 0.7 0.9
1.1
VOLTAGE BUS NAME MAX. MIN. BASE CONT DEV. *-----*
27471 PEDR-115 115 1.100 0.837 0.932 0.834 -0.098 .
VAR GENERATORS ON VAR
LIMIT

```

```

SUMMARY OF FAILED CONTINGENCIES
(OVLD> 1.00 RATEB, V.COLLAPSE<0.50, VOLT>1.10, VOLT<0.84, BUSES/ISLD>= 1)
-----
CONTINGENCY 274 : BRANCH 1090 ++UNIT 287

----- POST-CONTINGENCY RESULTS -----
SOLN OVERLOAD DELT-FLOW HIGH-VOLT LOW-VOLT SWING GEN ITER MM
- 0-0.00 0- 0.0 0-0.00 1-0.83 ( 55, 13) 4 0.07

OUTAGES FROM BUS TO BUS ID BASE CASE RATING-B P.U.-B
27431 SMAR-115 115 27461 STOM-115 115 1 77 266 0.29
21135 ACAJ-U5 13.8 5 59 65

* AREA 2 * 0.7 0.9
1.1
VOLTAGE BUS NAME MAX. MIN. BASE CONT DEV. *-----*
27471 PEDR-115 115 1.100 0.837 0.932 0.825 -0.107 .
VAR GENERATORS ON VAR
LIMIT

```

```

SUMMARY OF FAILED CONTINGENCIES
(OVLD> 1.00 RATEB, V.COLLAPSE<0.50, VOLT>1.10, VOLT<0.84, BUSES/ISLD>= 1)
-----
CONTINGENCY 288 : BRANCH 1077 ++BRANCH 1055

----- POST-CONTINGENCY RESULTS -----
SOLN OVERLOAD DELT-FLOW HIGH-VOLT LOW-VOLT SWING GEN ITER MM
- 1-1.44 0- 0.0 0-0.00 1-0.84 ( 67, 15) 4 0.05

OUTAGES FROM BUS TO BUS ID BASE CASE RATING-B P.U.-B
27361 SANT-115 115 27371 NEJA-115 115 1 68 266 0.26
27131 ACAJ-115 115 27441 ATEO-115 115 1 95 266 0.36

OVERLOAD FROM BUS TO BUS ID BASE CONT ---P.U. FLOWS---
27411 SONS-115 115 27441 ATEO-115 115 1 78 192 1.70 1.44 1.44

* AREA 2 * 0.7 0.9
1.1
VOLTAGE BUS NAME MAX. MIN. BASE CONT DEV. *-----*

```

```

27361 SANT-115 115      1.100      0.837      0.959      0.835      -0.124      .      -----
VAR                                                                .
LIMIT                                                                .
21101 5NOV-U1 13.8      7.0         0.0         5.9         7.0         1.1         .      +

```

S U M M A R Y O F F A I L E D C O N T I N G E N C I E S
(OVLD> 1.00 RATEB, V.COLLAPSE<0.50, VOLT>1.10, VOLT<0.84, BUSES/ISLD>= 1)

CONTINGENCY 290 : BRANCH 1090 ++BRANCH 1055

```

----- POST-CONTINGENCY RESULTS -----
SOLN  OVERLOAD DELT-FLOW HIGH-VOLT  LOW-VOLT  SWING GEN ITER  MM
-      1-1.31    0- 0.0    0-0.00    3-0.78  ( 68, 15)  4  0.07

OUTAGES FROM BUS      TO BUS      ID  BASE CASE  RATING-B  P.U.-B
27431 SMAR-115 115 27461 STOM-115 115 1      77      266      0.29
27131 ACAJ-115 115 27441 ATEO-115 115 1      95      266      0.36

```

```

OVERLOAD FROM BUS      TO BUS      ID  BASE CONT  ---P.U. FLOWS---
27411 SONS-115 115 27441 ATEO-115 115 1      78  174  1.54  1.31  1.31

```

```

* AREA 2 *
1.1
VOLTAGE BUS NAME      MAX.      MIN.      BASE      CONT      DEV.      *-----*-----*-----*-----*
27421 NCUS-115 115      1.100      0.837      0.943      0.823      -0.120      .      -----
27461 STOM-115 115      1.100      0.837      0.944      0.799      -0.145      .
27471 PEDR-115 115      1.100      0.837      0.932      0.783      -0.149      .
VAR                                                                .
LIMIT                                                                .
21101 5NOV-U1 13.8      7.0         0.0         5.9         7.0         1.1         .      +

```

S U M M A R Y O F F A I L E D C O N T I N G E N C I E S
(OVLD> 1.00 RATEB, V.COLLAPSE<0.50, VOLT>1.10, VOLT<0.84, BUSES/ISLD>= 1)

CONTINGENCY 329 : BRANCH 1070 ++BRANCH 1065

```

----- POST-CONTINGENCY RESULTS -----
SOLN  OVERLOAD DELT-FLOW HIGH-VOLT  LOW-VOLT  SWING GEN ITER  MM
VC-   3-1.65    0- 0.0    0-0.00    6-0.00  ( 20, 11)  8  0.08

OUTAGES FROM BUS      TO BUS      ID  BASE CASE  RATING-B  P.U.-B
27211 BERL-115 115 27341 SMIG-115 115 1      58      133      0.44
27181 15SE-115 115 27341 SMIG-115 115 1      33      133      0.25

```

```

OVERLOAD FROM BUS      TO BUS      ID  BASE CONT  ---P.U. FLOWS---
27321 SRAF-115 115 27391 TECO-115 115 1      26  219  1.94  1.65  1.65
27341 SMIG-115 115 27401 OZAT-115 115 1      10 -184  1.63  1.38  1.38
27391 TECO-115 115 27401 OZAT-115 115 1      10  204  1.81  1.53  1.53

```

```

* AREA 2 *
1.1
VOLTAGE BUS NAME      MAX.      MIN.      BASE      CONT      DEV.      *-----*-----*-----*
24341 SMIG-46 46.0      1.100      0.837      1.014      0.000      -1.014      .
24391 TECO-46 46.0      1.100      0.837      1.007      0.680      -0.327      .
24401 OZAT-46 46.0      1.100      0.837      1.009      0.422      -0.587      .
27341 SMIG-115 115      1.100      0.837      0.962      0.167      -0.795      .
27391 TECO-115 115      1.100      0.837      0.962      0.659      -0.303      .
27401 OZAT-115 115      1.100      0.837      0.956      0.417      -0.539      .
VAR                                                                .
LIMIT                                                                .
21101 5NOV-U1 13.8      7.0         0.0         5.9         7.0         1.1         .      +

```

S U M M A R Y O F F A I L E D C O N T I N G E N C I E S
(OVLD> 1.00 RATEB, V.COLLAPSE<0.50, VOLT>1.10, VOLT<0.84, BUSES/ISLD>= 1)

CONTINGENCY 333 : BRANCH 1073 ++BRANCH 1070

```

----- POST-CONTINGENCY RESULTS -----
SOLN  OVERLOAD DELT-FLOW HIGH-VOLT  LOW-VOLT  SWING GEN ITER  MM

```

```

-          1-1.23    0- 0.0    0-0.00    6-0.66    ( 77, 16)  4    0.13

OUTAGES FROM BUS          TO BUS          ID  BASE CASE  RATING-B  P.U.-B
27321 SRAF-115 115 27391 TECO-115 115 1    26    133    0.20
27211 BERL-115 115 27341 SMIG-115 115 1    58    133    0.44

OVERLOAD FROM BUS          TO BUS          ID  BASE  CONT  ---P.U. FLOWS---
27181 15SE-115 115 27341 SMIG-115 115 1    33   163   1.44  1.23  1.23
  
```

```

* AREA      2 *
1.1
VOLTAGE  BUS NAME          MAX.      MIN.      BASE      CONT      DEV.      *-----*-----*-----*-----*
24341 SMIG-46 46.0        1.100    0.837    1.014    0.744    -0.270    . ----- .
24391 TECO-46 46.0        1.100    0.837    1.007    0.682    -0.325    ----- .
24401 OZAT-46 46.0        1.100    0.837    1.009    0.707    -0.302    ----- .
27341 SMIG-115 115        1.100    0.837    0.962    0.726    -0.236    . ----- .
27391 TECO-115 115        1.100    0.837    0.962    0.661    -0.301    ----- .
27401 OZAT-115 115        1.100    0.837    0.956    0.679    -0.277    ----- .

VAR
LIMIT
21101 5NOV-U1 13.8        7.0      0.0      5.9      7.0      1.1      +
  
```

S U M M A R Y O F F A I L E D C O N T I N G E N C I E S
(OVLD> 1.00 RATEB, V.COLLAPSE<0.50, VOLT>1.10, VOLT<0.84, BUSES/ISLD>= 1)

CONTINGENCY 344 : BRANCH 1090 ++BRANCH 1056

```

----- POST-CONTINGENCY RESULTS -----
SOLN  OVERLOAD DELT-FLOW HIGH-VOLT  LOW-VOLT  SWING GEN ITER  MM
-      0-0.00    0- 0.0    0-0.00    1-0.83  ( 60, 13)  4    0.03
  
```

```

OUTAGES FROM BUS          TO BUS          ID  BASE CASE  RATING-B  P.U.-B
27431 SMAR-115 115 27461 STOM-115 115 1    77    266    0.29
27161 AHUA-115 115 27351 SANA-115 115 1    61    133    0.46

* AREA      2 *
1.1
VOLTAGE  BUS NAME          MAX.      MIN.      BASE      CONT      DEV.      *-----*-----*-----*-----*
27471 PEDR-115 115        1.100    0.837    0.932    0.831    -0.101    . ----- .

VAR
LIMIT
  
```

S U M M A R Y O F F A I L E D C O N T I N G E N C I E S
(OVLD> 1.00 RATEB, V.COLLAPSE<0.50, VOLT>1.10, VOLT<0.84, BUSES/ISLD>= 1)

CONTINGENCY 359 : BRANCH 1090 ++UNIT 301

```

----- POST-CONTINGENCY RESULTS -----
SOLN  OVERLOAD DELT-FLOW HIGH-VOLT  LOW-VOLT  SWING GEN ITER  MM
-      0-0.00    0- 0.0    0-0.00    1-0.84  ( 62, 14)  2    0.02
  
```

```

OUTAGES FROM BUS          TO BUS          ID  BASE CASE  RATING-B  P.U.-B
27431 SMAR-115 115 27461 STOM-115 115 1    77    266    0.29
21171 CGRA-U1 13.8        1        68        68

* AREA      2 *
1.1
VOLTAGE  BUS NAME          MAX.      MIN.      BASE      CONT      DEV.      *-----*-----*-----*-----*
27471 PEDR-115 115        1.100    0.837    0.932    0.835    -0.097    . ----- .

VAR
LIMIT
21101 5NOV-U1 13.8        7.0      0.0      5.9      7.0      1.1      +
  
```

S U M M A R Y O F F A I L E D C O N T I N G E N C I E S
(OVLD> 1.00 RATEB, V.COLLAPSE<0.50, VOLT>1.10, VOLT<0.84, BUSES/ISLD>= 1)

CONTINGENCY 360 : BRANCH 1090 ++UNIT 302

----- POST-CONTINGENCY RESULTS -----

Escenario de demanda media del mes de marzo

SOLN	OVERLOAD	DELT-FLOW	HIGH-VOLT	LOW-VOLT	SWING GEN	ITER	MM
-	0-0.00	0- 0.0	0-0.00	1-0.84	(62, 14)	2	0.04

OUTAGES	FROM BUS	TO BUS	ID	BASE CASE	RATING-B	P.U.-B
27431	SMAR-115 115	27461 STOM-115 115	1	77	266	0.29
21172	CGRA-U2 13.8		2	68	68	

* AREA 2 *

1.1

VOLTAGE	BUS NAME	MAX.	MIN.	BASE	CONT	DEV.	
27471	PEDR-115 115	1.100	0.837	0.932	0.835	-0.097	*-----*-----*-----*

VAR LIMIT

21101	5NOV-U1 13.8	7.0	0.0	5.9	7.0	1.1	0.7 0.9
-------	--------------	-----	-----	-----	-----	-----	---------

GENERATORS ON VAR

SUMMARY OF FAILED CONTINGENCIES
(OVLDT> 1.00 RATEB, V.COLLAPSE<0.50, VOLT>1.10, VOLT<0.84, BUSES/ISLD>= 1)

CONTINGENCY 361 : BRANCH 1090 ++UNIT 303

----- POST-CONTINGENCY RESULTS -----

SOLN	OVERLOAD	DELT-FLOW	HIGH-VOLT	LOW-VOLT	SWING GEN	ITER	MM
-	0-0.00	0- 0.0	0-0.00	1-0.84	(61, 14)	4	0.05

OUTAGES	FROM BUS	TO BUS	ID	BASE CASE	RATING-B	P.U.-B
27431	SMAR-115 115	27461 STOM-115 115	1	77	266	0.29
21181	15SE-U1 13.8		1	80	80	

* AREA 2 *

1.1

VOLTAGE	BUS NAME	MAX.	MIN.	BASE	CONT	DEV.	
27471	PEDR-115 115	1.100	0.837	0.932	0.836	-0.096	*-----*-----*-----*

VAR LIMIT

21101	5NOV-U1 13.8	7.0	0.0	5.9	7.0	1.1	0.7 0.9
-------	--------------	-----	-----	-----	-----	-----	---------

GENERATORS ON VAR

SUMMARY OF FAILED CONTINGENCIES
(OVLDT> 1.00 RATEB, V.COLLAPSE<0.50, VOLT>1.10, VOLT<0.84, BUSES/ISLD>= 1)

CONTINGENCY 367 : BRANCH 1090 ++BRANCH 1077

----- POST-CONTINGENCY RESULTS -----

SOLN	OVERLOAD	DELT-FLOW	HIGH-VOLT	LOW-VOLT	SWING GEN	ITER	MM
VC-	0-0.00	0- 0.0	0-0.00	7-0.75	(63, 14)	9	31.64

OUTAGES	FROM BUS	TO BUS	ID	BASE CASE	RATING-B	P.U.-B
27431	SMAR-115 115	27461 STOM-115 115	1	77	266	0.29
27361	SANT-115 115	27371 NEJA-115 115	1	68	266	0.26

* AREA 2 *

1.1

VOLTAGE	BUS NAME	MAX.	MIN.	BASE	CONT	DEV.	
22421	NCUS-23 23.0	1.100	0.837	0.991	0.818	-0.173	*-----*-----*-----*
24461	STOM-46 46.0	1.100	0.837	1.013	0.817	-0.196	.-----.
24471	PEDR-46 46.0	1.100	0.837	1.017	0.817	-0.200	.-----.
27361	SANT-115 115	1.100	0.837	0.959	0.811	-0.148	.-----.
27421	NCUS-115 115	1.100	0.837	0.943	0.787	-0.156	.-----.
27461	STOM-115 115	1.100	0.837	0.944	0.765	-0.179	.-----.
27471	PEDR-115 115	1.100	0.837	0.932	0.751	-0.181	.-----.

VAR LIMIT

21161	AHUA-U1 13.8	18.0	-10.0	9.4	18.0	8.6	0.7 0.9
21162	AHUA-U2 13.8	18.0	-10.0	9.4	18.0	8.6	0.7 0.9

GENERATORS ON VAR

SUMMARY OF FAILED CONTINGENCIES
(OVLDT> 1.00 RATEB, V.COLLAPSE<0.50, VOLT>1.10, VOLT<0.84, BUSES/ISLD>= 1)

CONTINGENCY 473 : BRANCH 1073 ++BRANCH 1065

----- POST-CONTINGENCY RESULTS -----

Escenario de demanda media del mes de marzo

```

SOLN      OVERLOAD DELT-FLOW HIGH-VOLT  LOW-VOLT  SWING GEN ITER      MM
-          0-0.00    0- 0.0    0-0.00    2-0.81  ( 57, 13)  3    0.07

OUTAGES  FROM BUS          TO BUS          ID  BASE CASE  RATING-B  P.U.-B
27321  SRAF-115 115 27391  TECO-115 115 1      26      133      0.20
27181  15SE-115 115 27341  SMIG-115 115 1      33      133      0.25

```

```

* AREA      2 *
1.1
VOLTAGE  BUS NAME          MAX.      MIN.      BASE      CONT      DEV.      *-----*-----*-----*
27391  TECO-115 115          1.100    0.837    0.962    0.813    -0.149    .-----*
27401  OZAT-115 115          1.100    0.837    0.956    0.827    -0.129    .-----*

```

SUMMARY OF FAILED CONTINGENCIES
(OVLD> 1.00 RATEB, V.COLLAPSE<0.50, VOLT>1.10, VOLT<0.84, BUSES/ISLD>= 1)

CONTINGENCY 578 : BRANCH 1090 ++BRANCH 1057

```

----- POST-CONTINGENCY RESULTS -----
SOLN      OVERLOAD DELT-FLOW HIGH-VOLT  LOW-VOLT  SWING GEN ITER      MM
-          0-0.00    0- 0.0    0-0.00    1-0.83  ( 56, 13)  4    0.05

OUTAGES  FROM BUS          TO BUS          ID  BASE CASE  RATING-B  P.U.-B
27431  SMAR-115 115 27461  STOM-115 115 1      77      266      0.29
27161  AHUA-115 115 27411  SONS-115 115 1      11      133      0.08

```

```

* AREA      2 *
1.1
VOLTAGE  BUS NAME          MAX.      MIN.      BASE      CONT      DEV.      *-----*-----*
27471  PEDR-115 115          1.100    0.837    0.932    0.833    -0.099    .-----*
VAR
LIMIT                                         GENERATORS ON VAR

```

SUMMARY OF FAILED CONTINGENCIES
(OVLD> 1.00 RATEB, V.COLLAPSE<0.50, VOLT>1.10, VOLT<0.84, BUSES/ISLD>= 1)

CONTINGENCY 668 : BRANCH 1084 ++BRANCH 1070

```

----- POST-CONTINGENCY RESULTS -----
SOLN      OVERLOAD DELT-FLOW HIGH-VOLT  LOW-VOLT  SWING GEN ITER      MM
-          0-0.00    0- 0.0    0-0.00    3-0.79  ( 65, 14)  4    0.05

OUTAGES  FROM BUS          TO BUS          ID  BASE CASE  RATING-B  P.U.-B
27391  TECO-115 115 27401  OZAT-115 115 1      10      133      0.08
27211  BERL-115 115 27341  SMIG-115 115 1      58      133      0.44

```

```

* AREA      2 *
1.1
VOLTAGE  BUS NAME          MAX.      MIN.      BASE      CONT      DEV.      *-----*-----*
24401  OZAT-46 46.0          1.100    0.837    1.009    0.826    -0.183    .-----*
27341  SMIG-115 115          1.100    0.837    0.962    0.807    -0.155    .-----*
27401  OZAT-115 115          1.100    0.837    0.956    0.788    -0.168    .-----*

```

SUMMARY OF FAILED CONTINGENCIES
(OVLD> 1.00 RATEB, V.COLLAPSE<0.50, VOLT>1.10, VOLT<0.84, BUSES/ISLD>= 1)

CONTINGENCY 752 : BRANCH 1090 ++BRANCH 1085

```

----- POST-CONTINGENCY RESULTS -----
SOLN      OVERLOAD DELT-FLOW HIGH-VOLT  LOW-VOLT  SWING GEN ITER      MM
-          0-0.00    0- 0.0    0-0.00    3-0.80  ( 60, 13)  5    0.11

OUTAGES  FROM BUS          TO BUS          ID  BASE CASE  RATING-B  P.U.-B
27431  SMAR-115 115 27461  STOM-115 115 1      77      266      0.29
27411  SONS-115 115 27441  ATEO-115 115 1      78      133      0.59

```

```

* AREA      2 *
1.1
VOLTAGE  BUS NAME          MAX.      MIN.      BASE      CONT      DEV.      *-----*-----*
27421  NCUS-115 115          1.100    0.837    0.943    0.836    -0.107    .-----*
27461  STOM-115 115          1.100    0.837    0.944    0.813    -0.131    .-----*
27471  PEDR-115 115          1.100    0.837    0.932    0.798    -0.134    .-----*

```

El resumen de los resultados se presenta en la siguiente tabla:

Cuadro 1 –Voltaje en p.u. de barras con violaciones de voltaje (0.837 p.u.).

CONTINGENCIAS N-2	Barras con Violaciones de Voltaje						
	SMIG -115	TECO -115	OZAT -115	NCUS- 115	STOM -115	PEDR -115	SANT -115
SMAR-STOM & ATEO-GM ^{RESIM}				0.856	0.834	0.819	
SMAR-STOM & ACAJ-U5				0.864	0.842	0.825	
SANT-NEJA & ACAJ-ATEO							0.835
SMAR-STOM & ACAJ-ATEO				0.823	0.799	0.783	
BERL-SMIG & 15SE-SMIG	V.C.	V.C.	V.C.	V.C.	V.C.	V.C.	V.C.
SRAF-TECO & BERL-SMIG	0.726*	0.661*	0.679*				
SMAR-STOM & AHUA-SANA ^{RESIM}				0.872	0.851	0.837	
SMAR-STOM & CGRA-U1				0.870	0.849	0.835	
SMAR-STOM & 15SE-U1 ^{RESIM}				0.869	0.849	0.833	
SMAR-STOM & SANT-NEJA	V.C.	V.C.	V.C.	V.C.	V.C.	V.C.	V.C.
SRAF-TECO & 15SE-SMIG		0.813	0.827				
SMAR-STOM & AHUA-SONS ^{RESIM}				0.874	0.852	0.838	
TECO-OZAT & BERL-SMIG	0.807		0.788				
SMAR-STOM & SONS-ATEO					0.813	0.798	

Nota: (*) significa que también hay bajo voltaje en el secundario del transformador.
^{RESIM}, significa que el caso fue resimulado.

3.2.2. Caso B: Máxima transferencia Guatemala --> El Salvador 40 MW.

Archivo: MM_GE40.raw (versión 26 convertida de MM_GE40.sav)

Con el objeto de evitar el analizar los casos menos críticos, primeramente se hizo un análisis de la cantidad de casos de contingencias N-2 se producen en función del límites inferior de voltaje para el cual se considera un abatimiento del voltaje extremo:

Límite inferior de voltaje en nodos (p.u.)	Número de casos con violación del límite inferior de voltaje	Número de casos con colapso de voltaje	Número de casos de no convergencia
0.90	308	2	0
0.89	159	2	0
0.88	85	2	0
0.87	71	2	0
0.86	68	2	0
0.85	67	2	0
0.84	67	2	0
0.83	16	2	0

Del cuadro anterior, se concluye que un caso de “No-convergencia” y que un caso de “colapso de voltaje”, son una constante en todos los escenarios posibles; y que además, como punto de partida, se analizarán los 13 casos de bajo voltaje con respecto a la violación de límite inferior de 0.83 p.u. de voltaje, cuyos resultados se muestran a continuación:

```

*** CONTINGENCY RESULTS SUMMARY ***

TOTAL NO. OF CONTINGENCIES TESTED      = 861
I.   CONVERGED CONTINGENCIES            = 859
II.  VOLTAGE COLLAPSE CONTINGENCIES     = 2
III. NOT CONVERGED CONTINGENCIES        = 0

*** FAILURE SUMMARY ***
FAILURE CRITERIA                        NO. OF WORST CASE
----- CRITERIA ----- FAILURES INDEX VALUE
I.   CONVERGED ( 859 CONTINGENCIES) :
      AT LEAST ( 1) BUSES PER ISLAND      0      0 ( 0)
      OVERLOAD ABOVE (1.00) PU OF RATING (B) 62     334 ( 1.72)
      CHANGE IN FLOW ABOVE (999.0%)        0      0 ( 0.0)
      BUS VOLTAGE ABOVE ( 1.10) P.U.       0      0 ( 0.00)
      BUS VOLTAGE BELOW ( 0.83) P.U.      16     399 ( 0.66)
      SUBTOTAL                            73
II.  VOLTAGE COLLAPSE:                    2
III. NOT-CONVERGED (MM > 0.10)           0

TOTAL FAILED CONTINGENCIES :             75
(OUT OF 861 CONTINGENCIES TESTED)

```

Los resultados indican lo siguiente:

- El TPLAN realizó 861 contingencias de líneas de transmisión y de generación.
- Hay 16 casos de contingencias críticas presentan violación del límite inferior de voltaje (0.83 p.u.).
- Hay 62 casos de violación por sobrecarga de líneas de transmisión, los cuales no son objeto del presente estudio.
- Hay 2 casos de colapso de voltaje

Un resumen detallado de los casos de bajo voltaje se muestra a continuación:

```

SUMMARY OF FAILED CONTINGENCIES
(OVLD> 1.00 RATEB, V.COLLAPSE<0.50, VOLT>1.10, VOLT<0.83, BUSES/ISLD=>= 1)
-----
CONTINGENCY 44 : BRANCH 1090 ++UNIT 338

----- POST-CONTINGENCY RESULTS -----
SOLN OVERLOAD DELT-FLOW HIGH-VOLT LOW-VOLT SWING GEN ITER MM
-      0-0.00 0- 0.0 0-0.00 1-0.83 ( 44, 11) 4 0.08

OUTAGES FROM BUS TO BUS ID BASE CASE RATING-B P.U.-B
27431 SMAR-115 115 27461 STOM-115 115 1 80 266 0.30
21441 ATEO-GM 13.8 1 16 17

* AREA 2 *
VOLTAGE BUS NAME MAX. MIN. BASE CONT DEV. *-----*-----*-----*
27471 PEDR-115 1.100 0.830 0.928 0.826 -0.102 . -0.102 .
VAR GENERATORS ON VAR LIMIT

```

```

SUMMARY OF FAILED CONTINGENCIES
(OVLD> 1.00 RATEB, V.COLLAPSE<0.50, VOLT>1.10, VOLT<0.83, BUSES/ISLD=>= 1)
-----

```

CONTINGENCY 268 : BRANCH 1090 ++BRANCH 1055

```

----- POST-CONTINGENCY RESULTS -----
SOLN   OVERLOAD DELT-FLOW HIGH-VOLT  LOW-VOLT  SWING GEN ITER   MM
-      1-1.29   0- 0.0   0-0.00   3-0.78   ( 54, 12)  4   0.08

OUTAGES FROM BUS      TO BUS      ID  BASE CASE  RATING-B  P.U.-B
27431 SMAR-115 115 27461 STOM-115 115 1      80      266      0.30
27131 ACAJ-115 115 27441 ATEO-115 115 1      88      266      0.33

OVERLOAD FROM BUS      TO BUS      ID  BASE  CONT  ---P.U. FLOWS---
27411 SONS-115 115 27441 ATEO-115 115 1      80    171   1.51  1.29  1.29

* AREA 2 *
VOLTAGE BUS NAME  MAX.  MIN.  BASE  CONT  DEV.  0.7  0.9  1.1
27421 NCUS-115  1.100  0.830  0.939  0.821  -0.118  .  .  .
27461 STOM-115  1.100  0.830  0.941  0.797  -0.144  .  .  .
27471 PEDR-115  1.100  0.830  0.928  0.781  -0.147  .  .  .
VAR
GENERATORS ON VAR LIMIT

```

S U M M A R Y O F F A I L E D C O N T I N G E N C I E S
(OVLDT> 1.00 RATEB, V.COLLAPSE<0.50, VOLT>1.10, VOLT<0.83, BUSES/ISLD>= 1)

CONTINGENCY 307 : BRANCH 1090 ++BRANCH 1056

```

----- POST-CONTINGENCY RESULTS -----
SOLN   OVERLOAD DELT-FLOW HIGH-VOLT  LOW-VOLT  SWING GEN ITER   MM
-      0-0.00   0- 0.0   0-0.00   1-0.82   ( 48, 11)  4   0.06

OUTAGES FROM BUS      TO BUS      ID  BASE CASE  RATING-B  P.U.-B
27431 SMAR-115 115 27461 STOM-115 115 1      80      266      0.30
27161 AHUA-115 115 27351 SANA-115 115 1      71      133      0.53

* AREA 2 *
VOLTAGE BUS NAME  MAX.  MIN.  BASE  CONT  DEV.  0.7  0.9  1.1
27471 PEDR-115  1.100  0.830  0.928  0.822  -0.106  .  .  .
VAR
GENERATORS ON VAR LIMIT

```

S U M M A R Y O F F A I L E D C O N T I N G E N C I E S
(OVLDT> 1.00 RATEB, V.COLLAPSE<0.50, VOLT>1.10, VOLT<0.83, BUSES/ISLD>= 1)

CONTINGENCY 314 : BRANCH 1086 ++BRANCH 1078

```

----- POST-CONTINGENCY RESULTS -----
SOLN   OVERLOAD DELT-FLOW HIGH-VOLT  LOW-VOLT  SWING GEN ITER   MM
-      2-1.32   0- 0.0   0-0.00   1-0.83   ( 67, 13)  4   0.09

OUTAGES FROM BUS      TO BUS      ID  BASE CASE  RATING-B  P.U.-B
27421 NCUS-115 115 27441 ATEO-115 115 1     104      266      0.39
27361 SANT-115 115 27441 ATEO-115 115 1      59      266      0.22

OVERLOAD FROM BUS      TO BUS      ID  BASE  CONT  ---P.U. FLOWS---
27161 AHUA-115 115 27351 SANA-115 115 1      71    140   1.24  1.05  1.05
27381 OPIC-115 115 27411 SONS-115 115 1      55   -176   1.56  1.32  1.32

* AREA 2 *
VOLTAGE BUS NAME  MAX.  MIN.  BASE  CONT  DEV.  0.7  0.9  1.1
27421 NCUS-115  1.100  0.830  0.939  0.828  -0.111  .  .  .
VAR
21101 5NOV-U1 1  7.0  0.0  5.7  7.0  1.3  +
GENERATORS ON VAR LIMIT

```

S U M M A R Y O F F A I L E D C O N T I N G E N C I E S
(OVLDT> 1.00 RATEB, V.COLLAPSE<0.50, VOLT>1.10, VOLT<0.83, BUSES/ISLD>= 1)

CONTINGENCY 319 : BRANCH 1070 ++BRANCH 1065

Escenario de demanda media del mes de marzo

```

----- POST-CONTINGENCY RESULTS -----
SOLN      OVERLOAD DELT-FLOW HIGH-VOLT  LOW-VOLT  SWING GEN ITER      MM
VC-        3-1.64    0- 0.0    0-0.00    6-0.00    (  5,  9)  8    0.07

OUTAGES  FROM BUS          TO BUS          ID  BASE CASE  RATING-B  P.U.-B
27211 BERL-115 115 27341 SMIG-115 115 1      58      133      0.44
27181 15SE-115 115 27341 SMIG-115 115 1      33      133      0.25

OVERLOAD FROM BUS          TO BUS          ID  BASE  CONT  ---P.U. FLOWS---
27321 SRAF-115 115 27391 TECO-115 115 1      26      218    1.93  1.64  1.64
27341 SMIG-115 115 27401 OZAT-115 115 1      10     -182    1.61  1.37  1.37
27391 TECO-115 115 27401 OZAT-115 115 1      10      202    1.79  1.52  1.52

* AREA      2 *
VOLTAGE  BUS NAME      MAX.      MIN.      BASE      CONT      DEV.      0.7      0.9      1.1
          *-----*-----*-----*-----*
24341 SMIG-46 4    1.100    0.830    1.013    0.000    -1.013    -----      .
24391 TECO-46 4    1.100    0.830    1.005    0.673    -0.332    -----      .
24401 OZAT-46 4    1.100    0.830    1.008    0.418    -0.590    -----      .
27341 SMIG-115 1.100    0.830    0.961    0.166    -0.795    -----      .
27391 TECO-115 1.100    0.830    0.960    0.653    -0.307    -----      .
27401 OZAT-115 1.100    0.830    0.955    0.413    -0.542    -----      .
VAR
21101 5NOV-U1 1    7.0      0.0      5.7      7.0      1.3
                                     GENERATORS ON VAR LIMIT
                                     +

```

S U M M A R Y O F F A I L E D C O N T I N G E N C I E S
(OVLD> 1.00 RATEB, V.COLLAPSE<0.50, VOLT>1.10, VOLT<0.83, BUSES/ISLD>= 1)

CONTINGENCY 326 : BRANCH 1090 ++BRANCH 1057

```

----- POST-CONTINGENCY RESULTS -----
SOLN      OVERLOAD DELT-FLOW HIGH-VOLT  LOW-VOLT  SWING GEN ITER      MM
-          0-0.00    0- 0.0    0-0.00    1-0.82    ( 45, 10)  4    0.05

OUTAGES  FROM BUS          TO BUS          ID  BASE CASE  RATING-B  P.U.-B
27431 SMAR-115 115 27461 STOM-115 115 1      80      266      0.30
27161 AHUA-115 115 27411 SONS-115 115 1      38      133      0.28

* AREA      2 *
VOLTAGE  BUS NAME      MAX.      MIN.      BASE      CONT      DEV.      0.7      0.9      1.1
          *-----*-----*-----*-----*
27471 PEDR-115 115    1.100    0.830    0.928    0.823    -0.105    -----      .
VAR
LIMIT
                                     GENERATORS ON VAR

```

S U M M A R Y O F F A I L E D C O N T I N G E N C I E S
(OVLD> 1.00 RATEB, V.COLLAPSE<0.50, VOLT>1.10, VOLT<0.83, BUSES/ISLD>= 1)

CONTINGENCY 342 : BRANCH 1090 ++UNIT 303

```

----- POST-CONTINGENCY RESULTS -----
SOLN      OVERLOAD DELT-FLOW HIGH-VOLT  LOW-VOLT  SWING GEN ITER      MM
-          0-0.00    0- 0.0    0-0.00    1-0.83    ( 51, 11)  4    0.03

OUTAGES  FROM BUS          TO BUS          ID  BASE CASE  RATING-B  P.U.-B
27431 SMAR-115 115 27461 STOM-115 115 1      80      266      0.30
21181 15SE-U1 13.8      1      80      80

* AREA      2 *
VOLTAGE  BUS NAME      MAX.      MIN.      BASE      CONT      DEV.      0.7      0.9      1.1
          *-----*-----*-----*-----*
27471 PEDR-115 1.100    0.830    0.928    0.828    -0.100    -----      .
VAR
                                     GENERATORS ON VAR LIMIT

```

S U M M A R Y O F F A I L E D C O N T I N G E N C I E S
(OVLD> 1.00 RATEB, V.COLLAPSE<0.50, VOLT>1.10, VOLT<0.83, BUSES/ISLD>= 1)

CONTINGENCY 343 : BRANCH 1090 ++UNIT 302

```

----- POST-CONTINGENCY RESULTS -----
SOLN      OVERLOAD DELT-FLOW HIGH-VOLT  LOW-VOLT  SWING GEN ITER      MM
-          0-0.00    0- 0.0    0-0.00    1-0.83    ( 51, 11)  3    0.04

```

```

OUTAGES FROM BUS          TO BUS          ID BASE CASE  RATING-B P.U.-B
27431 SMAR-115 115 27461 STOM-115 115 1      80      266     0.30
21172 CGRA-U2 13.8          2        68        68

* AREA 2 *
VOLTAGE BUS NAME      MAX.      MIN.      BASE      CONT      DEV.      0.7      0.9      1.1
27471 PEDR-115      1.100    0.830    0.928    0.827    -0.101    .      .      .
VAR
21101 5NOV-U1 13.8          7.0      0.0      5.7      7.0      1.3      .      .
GENERATORS ON VAR LIMIT

```

S U M M A R Y O F F A I L E D C O N T I N G E N C I E S
(OVLVD> 1.00 RATEB, V.COLLAPSE<0.50, VOLT>1.10, VOLT<0.83, BUSES/ISLD>= 1)

CONTINGENCY 344 : BRANCH 1090 ++UNIT 301

```

----- POST-CONTINGENCY RESULTS -----
SOLN  OVERLOAD DELT-FLOW HIGH-VOLT  LOW-VOLT  SWING GEN ITER  MM
-      0-0.00  0- 0.0  0-0.00  1-0.83  ( 51, 11)  3  0.03

```

```

OUTAGES FROM BUS          TO BUS          ID BASE CASE  RATING-B P.U.-B
27431 SMAR-115 115 27461 STOM-115 115 1      80      266     0.30
21171 CGRA-U1 13.8          1        68        68

* AREA 2 *
VOLTAGE BUS NAME      MAX.      MIN.      BASE      CONT      DEV.      0.7      0.9      1.1
27471 PEDR-115      1.100    0.830    0.928    0.826    -0.102    .      .      .
VAR
21101 5NOV-U1 13.8          7.0      0.0      5.7      7.0      1.3      .      .
GENERATORS ON VAR LIMIT

```

S U M M A R Y O F F A I L E D C O N T I N G E N C I E S
(OVLVD> 1.00 RATEB, V.COLLAPSE<0.50, VOLT>1.10, VOLT<0.83, BUSES/ISLD>= 1)

CONTINGENCY 350 : BRANCH 1090 ++BRANCH 1077

```

----- POST-CONTINGENCY RESULTS -----
SOLN  OVERLOAD DELT-FLOW HIGH-VOLT  LOW-VOLT  SWING GEN ITER  MM
VC-    0-0.00  0- 0.0  0-0.00  9-0.71  ( 44, 11)  1  39.02

```

```

OUTAGES FROM BUS          TO BUS          ID BASE CASE  RATING-B P.U.-B
27431 SMAR-115 115 27461 STOM-115 115 1      80      266     0.30
27361 SANT-115 115 27371 NEJA-115 115 1      74      266     0.28

* AREA 2 *
VOLTAGE BUS NAME      MAX.      MIN.      BASE      CONT      DEV.      0.7      0.9      1.1
22361 SANT-23 2  1.100    0.830    0.998    0.809    -0.189    .      .      .
22421 NCUS-23 2  1.100    0.830    0.986    0.778    -0.208    .      .      .
24461 STOM-46 4  1.100    0.830    1.009    0.777    -0.232    .      .      .
24471 PEDR-46 4  1.100    0.830    1.013    0.776    -0.237    .      .      .
27361 SANT-115 1.100    0.830    0.956    0.780    -0.176    .      .      .
27421 NCUS-115 1.100    0.830    0.939    0.751    -0.188    .      .      .
27441 ATEO-115 1.100    0.830    0.961    0.813    -0.148    .      .      .
27461 STOM-115 1.100    0.830    0.941    0.729    -0.212    .      .      .
27471 PEDR-115 1.100    0.830    0.928    0.714    -0.214    .      .      .
VAR
21161 AHUA-U1 1  18.0     -10.0    9.8      18.0     8.2      .      .      .
21162 AHUA-U2 1  18.0     -10.0    9.8      18.0     8.2      .      .      .
GENERATORS ON VAR LIMIT

```

S U M M A R Y O F F A I L E D C O N T I N G E N C I E S
(OVLVD> 1.00 RATEB, V.COLLAPSE<0.50, VOLT>1.10, VOLT<0.83, BUSES/ISLD>= 1)

CONTINGENCY 355 : BRANCH 1090 ++BRANCH 1061

```

----- POST-CONTINGENCY RESULTS -----
SOLN  OVERLOAD DELT-FLOW HIGH-VOLT  LOW-VOLT  SWING GEN ITER  MM
-      0-0.00  0- 0.0  0-0.00  1-0.83  ( 44, 11)  2  0.08

```

```

OUTAGES FROM BUS          TO BUS          ID BASE CASE  RATING-B P.U.-B
27431 SMAR-115 115 27461 STOM-115 115 1      80      266     0.30

```

27171 CGRA-115 115 27371 NEJA-115 115 1 58 266 0.22

```
* AREA      2 *
VOLTAGE  BUS NAME      MAX.      MIN.      BASE      CONT      DEV.      0.7      0.9      1.1
          27471 PEDR-115  1.100    0.830    0.928    0.829    -0.099    .        .        .
VAR                                             GENERATORS ON VAR LIMIT
```

S U M M A R Y O F F A I L E D C O N T I N G E N C I E S
(OVLDT> 1.00 RATEB, V.COLLAPSE<0.50, VOLT>1.10, VOLT<0.83, BUSES/ISLD=>= 1)

CONTINGENCY 356 : BRANCH 1090 ++BRANCH 1062

```
----- POST-CONTINGENCY RESULTS -----
SOLN      OVERLOAD DELT-FLOW HIGH-VOLT  LOW-VOLT  SWING GEN ITER  MM
-         0-0.00  0- 0.0  0-0.00  1-0.83  ( 44, 11)  2  0.08

OUTAGES  FROM BUS      TO BUS      ID  BASE CASE  RATING-B  P.U.-B
27431  SMAR-115 115 27461 STOM-115 115 1      80    266    0.30
27171  CGRA-115 115 27371 NEJA-115 115 2      58    266    0.22
```

```
* AREA      2 *
VOLTAGE  BUS NAME      MAX.      MIN.      BASE      CONT      DEV.      0.7      0.9      1.1
          27471 PEDR-115  1.100    0.830    0.928    0.829    -0.099    .        .        .
VAR                                             GENERATORS ON VAR LIMIT
```

S U M M A R Y O F F A I L E D C O N T I N G E N C I E S
(OVLDT> 1.00 RATEB, V.COLLAPSE<0.50, VOLT>1.10, VOLT<0.83, BUSES/ISLD=>= 1)

CONTINGENCY 472 : BRANCH 1073 ++BRANCH 1065

```
----- POST-CONTINGENCY RESULTS -----
SOLN      OVERLOAD DELT-FLOW HIGH-VOLT  LOW-VOLT  SWING GEN ITER  MM
-         1-1.01  0- 0.0  0-0.00  2-0.81  ( 43, 10)  3  0.05

OUTAGES  FROM BUS      TO BUS      ID  BASE CASE  RATING-B  P.U.-B
27321  SRAF-115 115 27391 TECO-115 115 1      26    133    0.20
27181  15SE-115 115 27341 SMIG-115 115 1      33    133    0.25
```

```
OVERLOAD FROM BUS      TO BUS      ID  BASE CONT  ---P.U. FLOWS---
27211  BERL-115 115 27341 SMIG-115 115 1      58  134  1.19  1.01  1.01
```

```
* AREA      2 *
VOLTAGE  BUS NAME      MAX.      MIN.      BASE      CONT      DEV.      0.7      0.9      1.1
          27391 TECO-115  1.100    0.830    0.960    0.810    -0.150    .        .        .
          27401 OZAT-115  1.100    0.830    0.955    0.824    -0.131    .        .        .
VAR                                             GENERATORS ON VAR LIMIT
```

S U M M A R Y O F F A I L E D C O N T I N G E N C I E S
(OVLDT> 1.00 RATEB, V.COLLAPSE<0.50, VOLT>1.10, VOLT<0.83, BUSES/ISLD=>= 1)

CONTINGENCY 521 : BRANCH 1073 ++BRANCH 1070

```
----- POST-CONTINGENCY RESULTS -----
SOLN      OVERLOAD DELT-FLOW HIGH-VOLT  LOW-VOLT  SWING GEN ITER  MM
-         1-1.23  0- 0.0  0-0.00  6-0.66  ( 65, 13)  4  0.04

OUTAGES  FROM BUS      TO BUS      ID  BASE CASE  RATING-B  P.U.-B
27321  SRAF-115 115 27391 TECO-115 115 1      26    133    0.20
27211  BERL-115 115 27341 SMIG-115 115 1      58    133    0.44
```

```
OVERLOAD FROM BUS      TO BUS      ID  BASE CONT  ---P.U. FLOWS---
27181  15SE-115 115 27341 SMIG-115 115 1      33  164  1.45  1.23  1.23
```

```
* AREA      2 *
VOLTAGE  BUS NAME      MAX.      MIN.      BASE      CONT      DEV.      0.7      0.9      1.1
          24341 SMIG-46 4  1.100    0.830    1.013    0.739    -0.274    .        .        .
          24391 TECO-46 4  1.100    0.830    1.005    0.677    -0.328    .        .        .
          24401 OZAT-46 4  1.100    0.830    1.008    0.702    -0.306    .        .        .
          27341 SMIG-115  1.100    0.830    0.961    0.722    -0.239    .        .        .
```

Escenario de demanda media del mes de marzo

27391	TECO-115	1.100	0.830	0.960	0.657	-0.303	-----	.
27401	OZAT-115	1.100	0.830	0.955	0.675	-0.280	-----	.
VAR							GENERATORS ON VAR LIMIT	
21101	5NOV-U1 1	7.0	0.0	5.7	7.0	1.3		+

S U M M A R Y O F F A I L E D C O N T I N G E N C I E S
(OVLD> 1.00 RATEB, V.COLLAPSE<0.50, VOLT>1.10, VOLT<0.83, BUSES/ISLD>= 1)

CONTINGENCY 676 : BRANCH 1084 ++BRANCH 1070

----- POST-CONTINGENCY RESULTS -----										
SOLN	OVERLOAD	DELT-FLOW	HIGH-VOLT	LOW-VOLT	SWING GEN	ITER	MM			
-	0-0.00	0- 0.0	0-0.00	3-0.79	(51, 11)	3	0.09			
OUTAGES	FROM BUS	TO BUS	ID	BASE CASE	RATING-B	P.U.-B				
27391	TECO-115 115	27401 OZAT-115 115	1	10	133	0.08				
27211	BERL-115 115	27341 SMIG-115 115	1	58	133	0.44				
* AREA	2 *						0.7	0.9	1.1	
VOLTAGE	BUS NAME	MAX.	MIN.	BASE	CONT	DEV.	*-----*	*-----*	*-----*	
24401	OZAT-46 4	1.100	0.830	1.008	0.824	-0.184	.	-----	.	
27341	SMIG-115	1.100	0.830	0.961	0.805	-0.156	.	-----	.	
27401	OZAT-115	1.100	0.830	0.955	0.786	-0.169	.	-----	.	
VAR							GENERATORS ON VAR LIMIT			

S U M M A R Y O F F A I L E D C O N T I N G E N C I E S
(OVLD> 1.00 RATEB, V.COLLAPSE<0.50, VOLT>1.10, VOLT<0.83, BUSES/ISLD>= 1)

CONTINGENCY 326 : BRANCH 1090 ++UNIT 287

----- POST-CONTINGENCY RESULTS -----										
SOLN	OVERLOAD	DELT-FLOW	HIGH-VOLT	LOW-VOLT	SWING GEN	ITER	MM			
-	0-0.00	0- 0.0	0-0.00	2-0.81	(45, 11)	4	0.07			
OUTAGES	FROM BUS	TO BUS	ID	BASE CASE	RATING-B	P.U.-B				
27431	SMAR-115 115	27461 STOM-115 115	1	80	266	0.30				
21135	ACAJ-U5 13.8		5	59	65					
* AREA	2 *						0.7	0.9	1.1	
VOLTAGE	BUS NAME	MAX.	MIN.	BASE	CONT	DEV.	*-----*	*-----*	*-----*	
27461	STOM-115	1.100	0.830	0.941	0.822	-0.119	.	-----	.	
27471	PEDR-115	1.100	0.830	0.928	0.807	-0.121	.	-----	.	
VAR							GENERATORS ON VAR LIMIT			

S U M M A R Y O F F A I L E D C O N T I N G E N C I E S
(OVLD> 1.00 RATEB, V.COLLAPSE<0.50, VOLT>1.10, VOLT<0.83, BUSES/ISLD>= 1)

CONTINGENCY 436 : BRANCH 1090 ++BRANCH 1085

----- POST-CONTINGENCY RESULTS -----										
SOLN	OVERLOAD	DELT-FLOW	HIGH-VOLT	LOW-VOLT	SWING GEN	ITER	MM			
-	0-0.00	0- 0.0	0-0.00	2-0.79	(48, 11)	4	0.05			
OUTAGES	FROM BUS	TO BUS	ID	BASE CASE	RATING-B	P.U.-B				
27431	SMAR-115 115	27461 STOM-115 115	1	80	266	0.30				
27411	SONS-115 115	27441 ATEO-115 115	1	80	133	0.60				
* AREA	2 *						0.7	0.9	1.1	
VOLTAGE	BUS NAME	MAX.	MIN.	BASE	CONT	DEV.	*-----*	*-----*	*-----*	
27461	STOM-115	1.100	0.830	0.941	0.806	-0.135	.	-----	.	
27471	PEDR-115	1.100	0.830	0.928	0.791	-0.137	.	-----	.	
VAR							GENERATORS ON VAR LIMIT			

El resumen de los resultados se presenta en la siguiente tabla:

Cuadro 1 – Voltaje en p.u. de barras con violaciones de voltaje (0.83 p.u.).

CONTINGENCIAS N-2 GUAT->ELSA 56 MW DEM. MEDIA, MARZO	Barras con Violaciones de Voltaje							
	SMIG -115	TECO -115	OZAT -115	NCUS- 115	STOM- 115	PEDR- 115	SANT -115	
SMAR-STOM & ATEO-GM						0.826		
SMAR-STOM & 15SE-U1						0.828		
SMAR-STOM & CGRA-U1						0.827		
SMAR-STOM & ACAJ-U5					0.822	0.807		
SMAR-STOM & ACAJ-ATEO				0.821	0.797	0.781		
SMAR-STOM & AHUA-SANA						0.822		
SMAR-STOM & SONS-ATEO					0.806	0.791		
NCUS-ATEO & SANT-ATEO				0.828				
SMAR-STOM & AHUA-SONS						0.823		
SMAR-STOM & CGRA-NEJA						0.829		
BERL-SMIG & 15SE-SMIG	V.C.	V.C.	V.C.	V.C.	V.C.	V.C.	V.C.	
SRAF-TECO & BERL-SMIG	0.722*	0.657*	0.675*					
TECO-OZAT & BERL-SMIG	0.805		0.786					
SRAF-TECO & 15SE-SMIG		0.810	0.824					
SMAR-STOM & SANT-NEJA	V.C.	V.C.	V.C.	V.C.	V.C.	V.C.	V.C.	

Nota: (*) significa que también hay bajo voltaje en el secundario del transformador.

3.2.3. Caso C: Máxima transferencia El Salvador --> Guatemala 106 MW

Archivo: MX_EG106.raw (versión 26 convertida de MX_EG106.sav)

Con el objeto de evitar el analizar los casos menos críticos, primeramente se hizo un análisis de la cantidad de casos de contingencias N-2 se producen en función del límites inferior de voltaje para el cual se considera un abatimiento del voltaje extremo:

Límite inferior de voltaje en nodos (p.u.)	Número de casos con violación del límite inferior de voltaje	Número de casos con colapso de voltaje y no convergencia
0.90	193	2
0.89	81	2
0.88	73	2
0.87	71	2
0.86	71	2
0.85	69	2
0.845	38	2
0.842	17	2
0.84	8	2

Del cuadro anterior, se concluye que un caso de “No-convergencia” y que un caso de “colapso de voltaje”, son una constante en todos los escenarios posibles; y que además, como punto de partida, se

analizarán los 17 casos de bajo voltaje con respecto a la violación de límite inferior de 0.842 p.u. de voltaje, cuyos resultados se muestran a continuación:

*** CONTINGENCY RESULTS SUMMARY ***

TOTAL NO. OF CONTINGENCIES TESTED = 1013
 I. CONVERGED CONTINGENCIES = 1011
 II. VOLTAGE COLLAPSE CONTINGENCIES = 2
 III. NOT CONVERGED CONTINGENCIES = 0

*** FAILURE SUMMARY ***

FAILURE CRITERIA	NO. OF FAILURES	WORST INDEX	CASE VALUE
I. CONVERGED (1011 CONTINGENCIES) :			
AT LEAST (1) BUSES PER ISLAND	0	0 (0)	
OVERLOAD ABOVE (1.00) PU OF RATING (B)	20	375 (1.70)	
CHANGE IN FLOW ABOVE (999.0%)	0	0 (0.0)	
BUS VOLTAGE ABOVE (1.10) P.U.	0	0 (0.00)	
BUS VOLTAGE BELOW (0.84) P.U.	17	838 (0.71)	
SUBTOTAL	35		
II. VOLTAGE COLLAPSE:	2		
III. NOT-CONVERGED (MM > 0.10)	0		
TOTAL FAILED CONTINGENCIES :	37		
(OUT OF 1013 CONTINGENCIES TESTED)			

Los resultados indican lo siguiente:

- El TPLAN realizó 1013 contingencias de líneas de transmisión y de generación.
- 17 casos de contingencias presentan violación del límite inferior de voltaje elegido para filtrar casos (0.84 p.u.).
- Hay 20 casos de violación por sobrecarga de líneas de transmisión, los cuales no son objeto del presente estudio.
- Hay 2 casos de colapso de voltaje.

Un resumen detallado de los casos de bajo voltaje se muestra a continuación:

SUMMARY OF FAILED CONTINGENCIES
(OVLD> 1.00 RATEB, V.COLLAPSE<0.50, VOLT>1.10, VOLT<0.84, BUSES/ISLD)= 1)

CONTINGENCY 132 : BRANCH 1090 ++UNIT 338

----- POST-CONTINGENCY RESULTS -----

SOLN	OVERLOAD	DELT-FLOW	HIGH-VOLT	LOW-VOLT	SWING GEN	ITER	MM
-	0-0.00	0- 0.0	0-0.00	1-0.84	(36, 14)	4	0.03

OUTAGES FROM BUS	TO BUS	ID	BASE	CASE	RATING-B	P.U.-B
27431 SMAR-115 115	27461 STOM-115 115	1	95	266	0.36	
21441 ATEO-GM 13.8		1	16	17		

* AREA 2 *

VOLTAGE	BUS NAME	MAX.	MIN.	BASE	CONT	DEV.	0.7	0.9	1.1
27471	PEDR-115	1.100	0.842	0.935	0.838	-0.097	*	*	*

VAR GENERATORS ON VAR LIMIT

SUMMARY OF FAILED CONTINGENCIES
(OVLD> 1.00 RATEB, V.COLLAPSE<0.50, VOLT>1.10, VOLT<0.84, BUSES/ISLD)= 1)

CONTINGENCY 238 : BRANCH 1090 ++UNIT 301

Escenario de demanda media del mes de marzo

```

----- POST-CONTINGENCY RESULTS -----
SOLN      OVERLOAD DELT-FLOW HIGH-VOLT  LOW-VOLT  SWING GEN ITER      MM
-          0-0.00    0- 0.0    0-0.00    1-0.84  ( 38, 14)  4    0.05

OUTAGES  FROM BUS          TO BUS          ID  BASE CASE  RATING-B  P.U.-B
27431  SMAR-115 115 27461  STOM-115 115 1      95      266      0.36
21171  CGRA-U1 13.8                1      70      70

* AREA    2 *
VOLTAGE  BUS NAME      MAX.      MIN.      BASE      CONT      DEV.      *-----*-----*-----*
27471  PEDR-115    1.100    0.842    0.935    0.840    -0.095    .          .
VAR
21101  5NOV-U1 13.8                7.0      0.0      5.3      7.0      1.7      +

```

S U M M A R Y O F F A I L E D C O N T I N G E N C I E S
(OVLD> 1.00 RATEB, V.COLLAPSE<0.50, VOLT>1.10, VOLT<0.84, BUSES/ISLD>= 1)

CONTINGENCY 252 : BRANCH 1090 ++UNIT 302

```

----- POST-CONTINGENCY RESULTS -----
SOLN      OVERLOAD DELT-FLOW HIGH-VOLT  LOW-VOLT  SWING GEN ITER      MM
-          0-0.00    0- 0.0    0-0.00    1-0.84  ( 38, 14)  4    0.06

OUTAGES  FROM BUS          TO BUS          ID  BASE CASE  RATING-B  P.U.-B
27431  SMAR-115 115 27461  STOM-115 115 1      95      266      0.36
21172  CGRA-U2 13.8                2      70      70

* AREA    2 *
VOLTAGE  BUS NAME      MAX.      MIN.      BASE      CONT      DEV.      *-----*-----*
27471  PEDR-115    1.100    0.842    0.935    0.840    -0.095    .          .
VAR
21101  5NOV-U1 13.8                7.0      0.0      5.3      7.0      1.7      +

```

S U M M A R Y O F F A I L E D C O N T I N G E N C I E S
(OVLD> 1.00 RATEB, V.COLLAPSE<0.50, VOLT>1.10, VOLT<0.84, BUSES/ISLD>= 1)

CONTINGENCY 364 : BRANCH 1090 ++UNIT 287

```

----- POST-CONTINGENCY RESULTS -----
SOLN      OVERLOAD DELT-FLOW HIGH-VOLT  LOW-VOLT  SWING GEN ITER      MM
-          0-0.00    0- 0.0    0-0.00    1-0.83  ( 37, 14)  3    0.03

OUTAGES  FROM BUS          TO BUS          ID  BASE CASE  RATING-B  P.U.-B
27431  SMAR-115 115 27461  STOM-115 115 1      95      266      0.36
21135  ACAJ-U5 13.8                5      59      65

* AREA    2 *
VOLTAGE  BUS NAME      MAX.      MIN.      BASE      CONT      DEV.      *-----*-----*
27471  PEDR-115    1.100    0.842    0.935    0.829    -0.106    .          .
VAR

```

S U M M A R Y O F F A I L E D C O N T I N G E N C I E S
(OVLD> 1.00 RATEB, V.COLLAPSE<0.50, VOLT>1.10, VOLT<0.84, BUSES/ISLD>= 1)

CONTINGENCY 382 : BRANCH 1090 ++BRANCH 1055

```

----- POST-CONTINGENCY RESULTS -----
SOLN      OVERLOAD DELT-FLOW HIGH-VOLT  LOW-VOLT  SWING GEN ITER      MM
-          1-1.05    0- 0.0    0-0.00    3-0.79  ( 43, 15)  4    0.02

OUTAGES  FROM BUS          TO BUS          ID  BASE CASE  RATING-B  P.U.-B
27431  SMAR-115 115 27461  STOM-115 115 1      95      266      0.36
27131  ACAJ-115 115 27441  ATEO-115 115 1      79      266      0.30

OVERLOAD FROM BUS          TO BUS          ID  BASE CONT  ---P.U. FLOWS---
27411  SONS-115 115 27441  ATEO-115 115 1      50  139  1.23  1.05  1.05

* AREA    2 *
VOLTAGE  BUS NAME      MAX.      MIN.      BASE      CONT      DEV.      *-----*-----*

```

Escenario de demanda media del mes de marzo

27421	NCUS-115	1.100	0.842	0.947	0.833	-0.114	.	-----	.
27461	STOM-115	1.100	0.842	0.948	0.810	-0.138	.	-----	.
27471	PEDR-115	1.100	0.842	0.935	0.794	-0.141	.	-----	.

VAR GENERATORS ON VAR LIMIT

S U M M A R Y O F F A I L E D C O N T I N G E N C I E S
(OVLD> 1.00 RATEB, V.COLLAPSE<0.50, VOLT>1.10, VOLT<0.84, BUSES/ISLD>= 1)

CONTINGENCY 425 : BRANCH 1070 ++BRANCH 1065

----- POST-CONTINGENCY RESULTS -----

SOLN	OVERLOAD	DELT-FLOW	HIGH-VOLT	LOW-VOLT	SWING	GEN	ITER	MM
VC-	3-1.67	0- 0.0	0-0.00	6-0.00	(5,	14)	9	0.03

OUTAGES	FROM BUS	TO BUS	ID	BASE	CASE	RATING-B	P.U.-B
27211	BERL-115	115 27341	SMIG-115	115	1	61	133 0.46
27181	15SE-115	115 27341	SMIG-115	115	1	36	133 0.27

OVERLOAD	FROM BUS	TO BUS	ID	BASE	CONT	---P.U.	FLWS---
27321	SRAF-115	115 27391	TECO-115	115	1	19	222 1.96 1.67 1.67
27341	SMIG-115	115 27401	OZAT-115	115	1	17	186 1.65 1.40 1.40
27391	TECO-115	115 27401	OZAT-115	115	1	5	206 1.82 1.55 1.55

* AREA	2 *	VOLTAGE	BUS NAME	MAX.	MIN.	BASE	CONT	DEV.	0.7	0.9	1.1
24341	SMIG-46	4	1.100	0.842	1.021	0.000	-1.021	*-----*	.	.	.
24391	TECO-46	4	1.100	0.842	1.011	0.689	-0.322	-----	.	.	.
24401	OZAT-46	4	1.100	0.842	1.015	0.428	-0.587	-----	.	.	.
27341	SMIG-115	1.100	0.842	0.969	0.170	-0.799	-----	.	.	.	
27391	TECO-115	1.100	0.842	0.966	0.668	-0.298	-----	.	.	.	
27401	OZAT-115	1.100	0.842	0.961	0.423	-0.538	-----	.	.	.	

VAR	21101	5NOV-U1	1	7.0	0.0	5.3	7.0	1.7	GENERATORS ON VAR LIMIT
21161	AHUA-U1	1	18.0	-10.0	11.6	18.0	6.4	+	
21162	AHUA-U2	1	18.0	-10.0	11.6	18.0	6.4	+	

S U M M A R Y O F F A I L E D C O N T I N G E N C I E S
(OVLD> 1.00 RATEB, V.COLLAPSE<0.50, VOLT>1.10, VOLT<0.84, BUSES/ISLD>= 1)

CONTINGENCY 441 : BRANCH 1090 ++BRANCH 1077

----- POST-CONTINGENCY RESULTS -----

SOLN	OVERLOAD	DELT-FLOW	HIGH-VOLT	LOW-VOLT	SWING	GEN	ITER	MM
VC-	0-0.00	0- 0.0	0-0.00	10-0.69	(39,	16)	2	60.65

OUTAGES	FROM BUS	TO BUS	ID	BASE	CASE	RATING-B	P.U.-B
27431	SMAR-115	115 27461	STOM-115	115	1	95	266 0.36
27361	SANT-115	115 27371	NEJA-115	115	1	91	266 0.34

* AREA	2 *	VOLTAGE	BUS NAME	MAX.	MIN.	BASE	CONT	DEV.	0.7	0.9	1.1
22361	SANT-23	2	1.100	0.842	1.006	0.790	-0.216	. -----	.	.	.
22421	NCUS-23	2	1.100	0.842	0.995	0.757	-0.238	. -----	.	.	.
23441	ATEO-34	3	1.100	0.842	1.008	0.829	-0.179	. -----	.	.	.
24461	STOM-46	4	1.100	0.842	1.017	0.756	-0.261	. -----	.	.	.
24471	PEDR-46	4	1.100	0.842	1.021	0.754	-0.267	. -----	.	.	.
27361	SANT-115	1.100	0.842	0.962	0.764	-0.198	. -----	.	.	.	
27421	NCUS-115	1.100	0.842	0.947	0.733	-0.214	. -----	.	.	.	
27441	ATEO-115	1.100	0.842	0.970	0.800	-0.170	. -----	.	.	.	
27461	STOM-115	1.100	0.842	0.948	0.710	-0.238	. -----	.	.	.	
27471	PEDR-115	1.100	0.842	0.935	0.694	-0.241	. -----	.	.	.	

VAR	21132	ACAJ-U2	1	8.0	-1.0	4.7	8.0	3.3	GENERATORS ON VAR LIMIT
									+

S U M M A R Y O F F A I L E D C O N T I N G E N C I E S
(OVLD> 1.00 RATEB, V.COLLAPSE<0.50, VOLT>1.10, VOLT<0.84, BUSES/ISLD>= 1)

CONTINGENCY 442 : BRANCH 1090 ++BRANCH 1057

Escenario de demanda media del mes de marzo

```

----- POST-CONTINGENCY RESULTS -----
SOLN      OVERLOAD DELT-FLOW HIGH-VOLT  LOW-VOLT    SWING GEN ITER      MM
-          0-0.00    0- 0.0    0-0.00    1-0.84    ( 37, 14)  4    0.13

OUTAGES FROM BUS          TO BUS          ID  BASE CASE  RATING-B  P.U.-B
27431 SMAR-115 115 27461 STOM-115 115 1      95      266      0.36
27161 AHUA-115 115 27411 SONS-115 115 1      61      133      0.46

* AREA      2 *
VOLTAGE BUS NAME      MAX.      MIN.      BASE      CONT      DEV.      *-----*-----*-----*
27471 PEDR-115      1.100    0.842    0.935    0.837    -0.098    .          .
VAR
GENERATORS ON VAR LIMIT

```

S U M M A R Y O F F A I L E D C O N T I N G E N C I E S
(OVLD> 1.00 RATEB, V.COLLAPSE<0.50, VOLT>1.10, VOLT<0.84, BUSES/ISLD>= 1)

CONTINGENCY 443 : BRANCH 1090 ++BRANCH 1054

```

----- POST-CONTINGENCY RESULTS -----
SOLN      OVERLOAD DELT-FLOW HIGH-VOLT  LOW-VOLT    SWING GEN ITER      MM
-          0-0.00    0- 0.0    0-0.00    1-0.84    ( 36, 14)  2    0.04

OUTAGES FROM BUS          TO BUS          ID  BASE CASE  RATING-B  P.U.-B
27431 SMAR-115 115 27461 STOM-115 115 1      95      266      0.36
27131 ACAJ-115 115 27411 SONS-115 115 2      78      133      0.59

* AREA      2 *
VOLTAGE BUS NAME      MAX.      MIN.      BASE      CONT      DEV.      *-----*-----*
27471 PEDR-115      1.100    0.842    0.935    0.841    -0.094    .          .
VAR
GENERATORS ON VAR LIMIT

```

S U M M A R Y O F F A I L E D C O N T I N G E N C I E S
(OVLD> 1.00 RATEB, V.COLLAPSE<0.50, VOLT>1.10, VOLT<0.84, BUSES/ISLD>= 1)

CONTINGENCY 444 : BRANCH 1090 ++BRANCH 1053

```

----- POST-CONTINGENCY RESULTS -----
SOLN      OVERLOAD DELT-FLOW HIGH-VOLT  LOW-VOLT    SWING GEN ITER      MM
-          0-0.00    0- 0.0    0-0.00    1-0.84    ( 37, 14)  3    0.05

OUTAGES FROM BUS          TO BUS          ID  BASE CASE  RATING-B  P.U.-B
27431 SMAR-115 115 27461 STOM-115 115 1      95      266      0.36
27131 ACAJ-115 115 27411 SONS-115 115 1      78      133      0.59

* AREA      2 *
VOLTAGE BUS NAME      MAX.      MIN.      BASE      CONT      DEV.      *-----*-----*
27471 PEDR-115      1.100    0.842    0.935    0.840    -0.095    .          .
VAR
GENERATORS ON VAR LIMIT

```

S U M M A R Y O F F A I L E D C O N T I N G E N C I E S
(OVLD> 1.00 RATEB, V.COLLAPSE<0.50, VOLT>1.10, VOLT<0.84, BUSES/ISLD>= 1)

CONTINGENCY 445 : BRANCH 1090 ++BRANCH 1085

```

----- POST-CONTINGENCY RESULTS -----
SOLN      OVERLOAD DELT-FLOW HIGH-VOLT  LOW-VOLT    SWING GEN ITER      MM
-          0-0.00    0- 0.0    0-0.00    2-0.81    ( 37, 14)  6    0.07

OUTAGES FROM BUS          TO BUS          ID  BASE CASE  RATING-B  P.U.-B
27431 SMAR-115 115 27461 STOM-115 115 1      95      266      0.36
27411 SONS-115 115 27441 ATEO-115 115 1      50      133      0.38

* AREA      2 *
VOLTAGE BUS NAME      MAX.      MIN.      BASE      CONT      DEV.      *-----*-----*
27461 STOM-115      1.100    0.842    0.948    0.821    -0.127    .          .
27471 PEDR-115      1.100    0.842    0.935    0.806    -0.129    .          .
VAR
GENERATORS ON VAR LIMIT

```

Escenario de demanda media del mes de marzo

S U M M A R Y O F F A I L E D C O N T I N G E N C I E S
(OVLD> 1.00 RATEB, V.COLLAPSE<0.50, VOLT>1.10, VOLT<0.84, BUSES/ISLD>= 1)

CONTINGENCY 446 : BRANCH 1090 ++BRANCH 1066

```

----- POST-CONTINGENCY RESULTS -----
SOLN   OVERLOAD DELT-FLOW HIGH-VOLT  LOW-VOLT   SWING GEN ITER   MM
-      0-0.00   0- 0.0    0-0.00    1-0.84    ( 37, 14)  2   0.03

OUTAGES FROM BUS          TO BUS          ID  BASE CASE   RATING-B  P.U.-B
27431 SMAR-115 115 27461 STOM-115 115 1     95     266     0.36
27181 15SE-115 115 27431 SMAR-115 115 1     53     133     0.40

* AREA 2 *
VOLTAGE BUS NAME      MAX.      MIN.      BASE      CONT      DEV.      0.7      0.9      1.1
27471 PEDR-115      1.100    0.842    0.935    0.841    -0.094    .        .        .
VAR
GENERATORS ON VAR LIMIT

```

S U M M A R Y O F F A I L E D C O N T I N G E N C I E S
(OVLD> 1.00 RATEB, V.COLLAPSE<0.50, VOLT>1.10, VOLT<0.84, BUSES/ISLD>= 1)

CONTINGENCY 447 : BRANCH 1090 ++BRANCH 1067

```

----- POST-CONTINGENCY RESULTS -----
SOLN   OVERLOAD DELT-FLOW HIGH-VOLT  LOW-VOLT   SWING GEN ITER   MM
-      0-0.00   0- 0.0    0-0.00    1-0.84    ( 37, 14)  2   0.03

OUTAGES FROM BUS          TO BUS          ID  BASE CASE   RATING-B  P.U.-B
27431 SMAR-115 115 27461 STOM-115 115 1     95     266     0.36
27181 15SE-115 115 27431 SMAR-115 115 2     53     133     0.40

* AREA 2 *
VOLTAGE BUS NAME      MAX.      MIN.      BASE      CONT      DEV.      0.7      0.9      1.1
27471 PEDR-115      1.100    0.842    0.935    0.841    -0.094    .        .        .

```

S U M M A R Y O F F A I L E D C O N T I N G E N C I E S
(OVLD> 1.00 RATEB, V.COLLAPSE<0.50, VOLT>1.10, VOLT<0.84, BUSES/ISLD>= 1)

CONTINGENCY 448 : BRANCH 1090 ++BRANCH 1061

```

----- POST-CONTINGENCY RESULTS -----
SOLN   OVERLOAD DELT-FLOW HIGH-VOLT  LOW-VOLT   SWING GEN ITER   MM
-      0-0.00   0- 0.0    0-0.00    1-0.84    ( 36, 14)  2   0.09

OUTAGES FROM BUS          TO BUS          ID  BASE CASE   RATING-B  P.U.-B
27431 SMAR-115 115 27461 STOM-115 115 1     95     266     0.36
27171 CGRA-115 115 27371 NEJA-115 115 1     67     266     0.25

* AREA 2 *
VOLTAGE BUS NAME      MAX.      MIN.      BASE      CONT      DEV.      0.7      0.9      1.1
27471 PEDR-115      1.100    0.842    0.935    0.840    -0.095    .        .        .

```

S U M M A R Y O F F A I L E D C O N T I N G E N C I E S
(OVLD> 1.00 RATEB, V.COLLAPSE<0.50, VOLT>1.10, VOLT<0.84, BUSES/ISLD>= 1)

CONTINGENCY 449 : BRANCH 1090 ++BRANCH 1062

```

----- POST-CONTINGENCY RESULTS -----
SOLN   OVERLOAD DELT-FLOW HIGH-VOLT  LOW-VOLT   SWING GEN ITER   MM
-      0-0.00   0- 0.0    0-0.00    1-0.84    ( 36, 14)  2   0.09

OUTAGES FROM BUS          TO BUS          ID  BASE CASE   RATING-B  P.U.-B
27431 SMAR-115 115 27461 STOM-115 115 1     95     266     0.36
27171 CGRA-115 115 27371 NEJA-115 115 2     67     266     0.25

* AREA 2 *
VOLTAGE BUS NAME      MAX.      MIN.      BASE      CONT      DEV.      0.7      0.9      1.1
27471 PEDR-115      1.100    0.842    0.935    0.840    -0.095    .        .        .
VAR
GENERATORS ON VAR LIMIT

```

S U M M A R Y O F F A I L E D C O N T I N G E N C I E S
(OVLVD> 1.00 RATEB, V.COLLAPSE<0.50, VOLT>1.10, VOLT<0.84, BUSES/ISLD>= 1)

CONTINGENCY 451 : BRANCH 1090 ++BRANCH 1074
----- POST-CONTINGENCY RESULTS -----
SOLN OVERLOAD DELT-FLOW HIGH-VOLT LOW-VOLT SWING GEN ITER MM
- 0-0.00 0- 0.0 0-0.00 1-0.84 (36, 14) 2 0.07

OUTAGES FROM BUS TO BUS ID BASE CASE RATING-B P.U.-B
27431 SMAR-115 115 27461 STOM-115 115 1 95 266 0.36
27321 SRAF-115 115 27431 SMAR-115 115 1 77 266 0.29

* AREA 2 *
VOLTAGE BUS NAME MAX. MIN. BASE CONT DEV. 0.7 0.9 1.1
27471 PEDR-115 1.100 0.842 0.935 0.841 -0.094 . - - - - .

S U M M A R Y O F F A I L E D C O N T I N G E N C I E S
(OVLVD> 1.00 RATEB, V.COLLAPSE<0.50, VOLT>1.10, VOLT<0.84, BUSES/ISLD>= 1)

CONTINGENCY 611 : BRANCH 1090 ++BRANCH 1078
----- POST-CONTINGENCY RESULTS -----
SOLN OVERLOAD DELT-FLOW HIGH-VOLT LOW-VOLT SWING GEN ITER MM
- 0-0.00 0- 0.0 0-0.00 3-0.80 (37, 14) 4 0.06

OUTAGES FROM BUS TO BUS ID BASE CASE RATING-B P.U.-B
27431 SMAR-115 115 27461 STOM-115 115 1 95 266 0.36
27361 SANT-115 115 27441 ATEO-115 115 1 38 266 0.14

* AREA 2 *
VOLTAGE BUS NAME MAX. MIN. BASE CONT DEV. 0.7 0.9 1.1
27421 NCUS-115 1.100 0.842 0.947 0.840 -0.107 . - - - - .
27461 STOM-115 1.100 0.842 0.948 0.816 -0.132 . - - - - .
27471 PEDR-115 1.100 0.842 0.935 0.801 -0.134 . - - - - .

S U M M A R Y O F F A I L E D C O N T I N G E N C I E S
(OVLVD> 1.00 RATEB, V.COLLAPSE<0.50, VOLT>1.10, VOLT<0.84, BUSES/ISLD>= 1)

CONTINGENCY 838 : BRANCH 1073 ++BRANCH 1070
----- POST-CONTINGENCY RESULTS -----
SOLN OVERLOAD DELT-FLOW HIGH-VOLT LOW-VOLT SWING GEN ITER MM
- 1-1.14 0- 0.0 0-0.00 6-0.71 (48, 14) 4 0.03

OUTAGES FROM BUS TO BUS ID BASE CASE RATING-B P.U.-B
27321 SRAF-115 115 27391 TECO-115 115 1 19 133 0.15
27211 BERL-115 115 27341 SMIG-115 115 1 61 133 0.46

OVERLOAD FROM BUS TO BUS ID BASE CONT ---P.U. FLOWS---
27181 15SE-115 115 27341 SMIG-115 115 1 36 152 1.35 1.14 1.14

* AREA 2 *
VOLTAGE BUS NAME MAX. MIN. BASE CONT DEV. 0.7 0.9 1.1
24341 SMIG-46 4 1.100 0.842 1.021 0.795 -0.226 . - - - - .
24391 TECO-46 4 1.100 0.842 1.011 0.736 -0.275 . - - - - .
24401 OZAT-46 4 1.100 0.842 1.015 0.760 -0.255 . - - - - .
27341 SMIG-115 1.100 0.842 0.969 0.770 -0.199 . - - - - .
27391 TECO-115 1.100 0.842 0.966 0.711 -0.255 . - - - - .
27401 OZAT-115 1.100 0.842 0.961 0.728 -0.233 . - - - - .

S U M M A R Y O F F A I L E D C O N T I N G E N C I E S
(OVLVD> 1.00 RATEB, V.COLLAPSE<0.50, VOLT>1.10, VOLT<0.84, BUSES/ISLD>= 1)

CONTINGENCY 843 : BRANCH 1073 ++BRANCH 1065
----- POST-CONTINGENCY RESULTS -----
SOLN OVERLOAD DELT-FLOW HIGH-VOLT LOW-VOLT SWING GEN ITER MM
- 0-0.00 0- 0.0 0-0.00 1-0.84 (33, 14) 4 0.04

OUTAGES FROM BUS TO BUS ID BASE CASE RATING-B P.U.-B
27321 SRAF-115 115 27391 TECO-115 115 1 19 133 0.15
27181 15SE-115 115 27341 SMIG-115 115 1 36 133 0.27

* AREA	2 *						0.7	0.9	1.1
VOLTAGE	BUS NAME	MAX.	MIN.	BASE	CONT	DEV.	*-----*	*-----*	*-----*
	27391 TECO-115	1.100	0.842	0.966	0.837	-0.129	.	-----	.
VAR									GENERATORS ON VAR LIMIT

S U M M A R Y O F F A I L E D C O N T I N G E N C I E S
(OVLDT> 1.00 RATEB, V.COLLAPSE<0.50, VOLT>1.10, VOLT<0.84, BUSES/ISLD>= 1)

CONTINGENCY 1552 : BRANCH 1084 ++BRANCH 1070
----- POST-CONTINGENCY RESULTS -----

SOLN	OVERLOAD	DELT-FLOW	HIGH-VOLT	LOW-VOLT	SWING	GEN	ITER	MM
-	0-0.00	0- 0.0	0-0.00	2-0.81	(40,	14)	3 0.04

OUTAGES	FROM BUS	TO BUS	ID	BASE	CASE	RATING-B	P.U.-B
	27391 TECO-115	115 27401 OZAT-115	115	1	5	133	0.04
	27211 BERL-115	115 27341 SMIG-115	115	1	61	133	0.46

* AREA	2 *						0.7	0.9	1.1
VOLTAGE	BUS NAME	MAX.	MIN.	BASE	CONT	DEV.	*-----*	*-----*	*-----*
	27341 SMIG-115	1.100	0.842	0.969	0.830	-0.139	.	-----	.
	27401 OZAT-115	1.100	0.842	0.961	0.811	-0.150	.	-----	.

El resumen de los resultados se presenta en la siguiente tabla:

Cuadro 1 – Voltaje en p.u. de barras con violaciones de voltaje (0.842 p.u.).

CONTINGENCIAS N-2 ELSA->GUAT 106 MW DEM- MEDIA, MARZO	Barras con Violaciones de Voltaje							
	SMIG -115	TECO -115	OZAT -115	NCUS -115	STOM -115	PEDR -115	SANT -115	
SMAR-STOM & ATEO-GM								0.838
SMAR-STOM & ACAJ-U5								0.829
SMAR-STOM & CGRA-U1								0.840
SMAR-STOM & ACAJ-ATEO				0.833	0.810			0.794
SMAR-STOM & SRAF-SMAR								0.841
SMAR-STOM & AHUA-SONS								0.837
SMAR-STOM & CGRA-NEJA								0.840
BERL-SMIG & 15SE-SMIG	V.C.	V.C.	V.C.	V.C.	V.C.	V.C.	V.C.	V.C.
SRAF-TECO & BERL-SMIG	0.770*	0.711*	0.728*					
SRAF-TECO & 15SE-SMIG		0.837						
SMAR-STOM & SANT-NEJA	V.C.	V.C.	V.C.	V.C.	V.C.	V.C.	V.C.	V.C.
TECO-OZAT & BERL-SMIG	0.830		0.811					
SMAR-STOM & ACAJ-SONS								0.841
SMAR-STOM & SONS-ATEO						0.821		0.806
SMAR-STOM & 15SE-SMAR						0.841		
SMAR-STOM & SANT-ATEO				0.840	0.816	0.801		

Nota: (*) significa que también hay bajo voltaje en el secundario del transformador.

3.2.4. Caso D: Máxima transferencia Honduras --> El Salvador 80 MW

Archivo: MM_HE80.raw (versión 26 convertida de MM_HE80.sav)

Con el objeto de evitar el analizar los casos menos críticos, primeramente se hizo un análisis de la cantidad de casos de contingencias N-2 que se producen en función del límites inferior de voltaje para el cual se considera un abatimiento del voltaje extremo:

Límite inferior de voltaje en nodos (p.u.)	Número de casos con violación del límite inferior de voltaje	Número de casos con colapso de voltaje y no convergencia
0.90	254	2
0.89	175	2
0.88	88	2
0.87	74	2
0.86	68	2
0.85	67	2
0.84	30	2
0.837	13	2
0.83	6	2

Del cuadro anterior, se concluye que dos casos de “No-convergencia” y que dos casos de “colapso de voltaje”, son una constante en todos los escenarios posibles; y que además, como punto de partida, se analizarán los 13 casos críticos de bajo voltaje con respecto a la violación de límite inferior de 0.837 p.u. de voltaje, cuyos resultados se muestran a continuación:

*** CONTINGENCY RESULTS SUMMARY ***

```

TOTAL NO. OF CONTINGENCIES TESTED      =    861
I.   CONVERGED CONTINGENCIES           =    859
II.  VOLTAGE COLLAPSE CONTINGENCIES    =     2
III. NOT CONVERGED CONTINGENCIES       =     0
    
```

*** FAILURE SUMMARY ***

FAILURE CRITERIA	NO. OF FAILURES	WORST INDEX	CASE VALUE
I. CONVERGED (859 CONTINGENCIES) :			
AT LEAST (1) BUSES PER ISLAND	0	0	(0)
OVERLOAD ABOVE (1.00) PU OF RATING (B)	43	334	(1.64)
CHANGE IN FLOW ABOVE (999.0%)	0	0	(0.0)
BUS VOLTAGE ABOVE (1.10) P.U.	0	0	(0.00)
BUS VOLTAGE BELOW (0.84) P.U.	13	671	(0.68)
SUBTOTAL	53		
II. VOLTAGE COLLAPSE:	2		
III. NOT-CONVERGED (MM > 0.10)	0		
TOTAL FAILED CONTINGENCIES :	55		
(OUT OF 861 CONTINGENCIES TESTED)			

Los resultados indican lo siguiente:

- El TPLAN realizó 861 contingencias de líneas de transmisión y de generación.
- 13 casos críticos presentan violación del límite inferior de voltaje de 0.837 p.u.
- Hay 43 casos de violación por sobrecarga de líneas de transmisión, los cuales no son objeto del presente estudio.
- Hay casos 2 casos de colapso de voltaje .

Un resumen detallado de los casos de bajo voltaje se muestra a continuación:

S U M M A R Y O F F A I L E D C O N T I N G E N C I E S
(OVLD> 1.00 RATEB, V.COLLAPSE<0.50, VOLT>1.10, VOLT<0.84, BUSES/ISLD>= 1)

```

CONTINGENCY 19 : BRANCH 1090 ++UNIT 302
----- POST-CONTINGENCY RESULTS -----
    
```

Escenario de demanda media del mes de marzo

SOLN	OVERLOAD	DELT-FLOW	HIGH-VOLT	LOW-VOLT	SWING GEN	ITER	MM
-	0-0.00	0- 0.0	0-0.00	1-0.83	(42, 29)	4	0.08

OUTAGES	FROM BUS	TO BUS	ID	BASE CASE	RATING-B	P.U.-B
27431	SMAR-115 115	27461 STOM-115 115	1	83	266	0.31
21172	CGRA-U2 13.8		2	68	68	

* AREA 2 * 0.7 0.9

1.1

VOLTAGE	BUS NAME	MAX.	MIN.	BASE	CONT	DEV.	*-----*
27471	PEDR-115 115	1.100	0.837	0.928	0.830	-0.098	-----*

VAR GENERATORS ON VAR
LIMIT

S U M M A R Y O F F A I L E D C O N T I N G E N C I E S
(OVLD> 1.00 RATEB, V.COLLAPSE<0.50, VOLT>1.10, VOLT<0.84, BUSES/ISLD>= 1)

CONTINGENCY 36 : BRANCH 1090 ++UNIT 303

----- POST-CONTINGENCY RESULTS -----

SOLN	OVERLOAD	DELT-FLOW	HIGH-VOLT	LOW-VOLT	SWING GEN	ITER	MM
-	0-0.00	0- 0.0	0-0.00	1-0.84	(38, 30)	3	0.09

OUTAGES	FROM BUS	TO BUS	ID	BASE CASE	RATING-B	P.U.-B
27431	SMAR-115 115	27461 STOM-115 115	1	83	266	0.31
21181	15SE-U1 13.8		1	80	80	

* AREA 2 * 0.7 0.9

1.1

VOLTAGE	BUS NAME	MAX.	MIN.	BASE	CONT	DEV.	*-----*
27471	PEDR-115 115	1.100	0.837	0.928	0.836	-0.092	-----*

VAR GENERATORS ON VAR
LIMIT

S U M M A R Y O F F A I L E D C O N T I N G E N C I E S
(OVLD> 1.00 RATEB, V.COLLAPSE<0.50, VOLT>1.10, VOLT<0.84, BUSES/ISLD>= 1)

CONTINGENCY 68 : BRANCH 1090 ++UNIT 338

----- POST-CONTINGENCY RESULTS -----

SOLN	OVERLOAD	DELT-FLOW	HIGH-VOLT	LOW-VOLT	SWING GEN	ITER	MM
-	0-0.00	0- 0.0	0-0.00	1-0.83	(36, 29)	4	0.08

OUTAGES	FROM BUS	TO BUS	ID	BASE CASE	RATING-B	P.U.-B
27431	SMAR-115 115	27461 STOM-115 115	1	83	266	0.31
21441	ATEO-GM 13.8		1	16	17	

* AREA 2 * 0.7 0.9

1.1

VOLTAGE	BUS NAME	MAX.	MIN.	BASE	CONT	DEV.	*-----*
27471	PEDR-115 115	1.100	0.837	0.928	0.833	-0.095	-----*

S U M M A R Y O F F A I L E D C O N T I N G E N C I E S
(OVLD> 1.00 RATEB, V.COLLAPSE<0.50, VOLT>1.10, VOLT<0.84, BUSES/ISLD>= 1)

CONTINGENCY 146 : BRANCH 1090 ++UNIT 287

----- POST-CONTINGENCY RESULTS -----

SOLN	OVERLOAD	DELT-FLOW	HIGH-VOLT	LOW-VOLT	SWING GEN	ITER	MM
-	0-0.00	0- 0.0	0-0.00	2-0.82	(37, 29)	5	0.10

OUTAGES	FROM BUS	TO BUS	ID	BASE CASE	RATING-B	P.U.-B
27431	SMAR-115 115	27461 STOM-115 115	1	83	266	0.31
21135	ACAJ-U5 13.8		5	50	65	

* AREA 2 * 0.7 0.9

1.1

VOLTAGE	BUS NAME	MAX.	MIN.	BASE	CONT	DEV.	*-----*
27461	STOM-115 115	1.100	0.837	0.941	0.834	-0.107	-----*

27471 PEDR-115 115 1.100 0.837 0.928 0.819 -0.109 . ----- .

S U M M A R Y O F F A I L E D C O N T I N G E N C I E S
(OVLD> 1.00 RATEB, V.COLLAPSE<0.50, VOLT>1.10, VOLT<0.84, BUSES/ISLD>= 1)

CONTINGENCY 340 : BRANCH 1090 ++BRANCH 1055

----- POST-CONTINGENCY RESULTS -----
SOLN OVERLOAD DELT-FLOW HIGH-VOLT LOW-VOLT SWING GEN ITER MM
- 1-1.25 0- 0.0 0-0.00 3-0.78 (45, 29) 4 0.09

OUTAGES	FROM BUS	TO BUS	ID	BASE	CASE	RATING-B	P.U.-B
27431	SMAR-115 115	27461 STOM-115 115	1	83		266	0.31
27131	ACAJ-115 115	27441 ATEO-115 115	1	93		266	0.35

OVERLOAD FROM BUS	TO BUS	ID	BASE	CONT	---P.U. FLOWS---
27411 SONS-115 115	27441 ATEO-115 115	1	76	166	1.47 1.25 1.25

* AREA 2 * 0.7 0.9

1.1
VOLTAGE BUS NAME MAX. MIN. BASE CONT DEV. *-----*-----*-----*-----*
27421 NCUS-115 115 1.100 0.837 0.940 0.821 -0.119 . ----- .
27461 STOM-115 115 1.100 0.837 0.941 0.797 -0.144 . ----- .
27471 PEDR-115 115 1.100 0.837 0.928 0.782 -0.146 . ----- .
VAR GENERATORS ON VAR
LIMIT

S U M M A R Y O F F A I L E D C O N T I N G E N C I E S
(OVLD> 1.00 RATEB, V.COLLAPSE<0.50, VOLT>1.10, VOLT<0.84, BUSES/ISLD>= 1)

CONTINGENCY 375 : BRANCH 1086 ++BRANCH 1078

----- POST-CONTINGENCY RESULTS -----
SOLN OVERLOAD DELT-FLOW HIGH-VOLT LOW-VOLT SWING GEN ITER MM
- 1-1.23 0- 0.0 0-0.00 2-0.82 (54, 31) 5 0.07

OUTAGES	FROM BUS	TO BUS	ID	BASE	CASE	RATING-B	P.U.-B
27421	NCUS-115 115	27441 ATEO-115 115	1	100		266	0.38
27361	SANT-115 115	27441 ATEO-115 115	1	63		266	0.24

OVERLOAD FROM BUS	TO BUS	ID	BASE	CONT	---P.U. FLOWS---
27381 OPIC-115 115	27411 SONS-115 115	1	58	-164	1.45 1.23 1.23

* AREA 2 * 0.7 0.9

1.1
VOLTAGE BUS NAME MAX. MIN. BASE CONT DEV. *-----*-----*-----*-----*
27421 NCUS-115 115 1.100 0.837 0.940 0.822 -0.118 . ----- .
27471 PEDR-115 115 1.100 0.837 0.928 0.832 -0.096 . ----- .
VAR GENERATORS ON VAR
LIMIT

S U M M A R Y O F F A I L E D C O N T I N G E N C I E S
(OVLD> 1.00 RATEB, V.COLLAPSE<0.50, VOLT>1.10, VOLT<0.84, BUSES/ISLD>= 1)

CONTINGENCY 383 : BRANCH 1070 ++BRANCH 1065

----- POST-CONTINGENCY RESULTS -----
SOLN OVERLOAD DELT-FLOW HIGH-VOLT LOW-VOLT SWING GEN ITER MM
VC- 3-1.62 0- 0.0 0-0.00 6-0.00 (-1, 30) 7 0.06

OUTAGES	FROM BUS	TO BUS	ID	BASE	CASE	RATING-B	P.U.-B
27211	BERL-115 115	27341 SMIG-115 115	1	62		133	0.47
27181	15SE-115 115	27341 SMIG-115 115	1	37		133	0.28

OVERLOAD FROM BUS	TO BUS	ID	BASE	CONT	---P.U. FLOWS---
27321 SRAF-115 115	27391 TECO-115 115	1	18	215	1.90 1.62 1.62
27341 SMIG-115 115	27401 OZAT-115 115	1	18	-179	1.58 1.35 1.35
27391 TECO-115 115	27401 OZAT-115 115	1	4	199	1.76 1.50 1.50

* AREA 2 * 0.7 0.9

1.1

VOLTAGE	BUS NAME	MAX.	MIN.	BASE	CONT	DEV.	*-----*
24341	SMIG-46 46.0	1.100	0.837	1.016	0.000	-1.016	-----
24391	TECO-46 46.0	1.100	0.837	1.003	0.662	-0.341	-----
24401	OZAT-46 46.0	1.100	0.837	1.008	0.411	-0.597	-----
27341	SMIG-115 115	1.100	0.837	0.964	0.163	-0.801	-----
27391	TECO-115 115	1.100	0.837	0.959	0.643	-0.316	-----
27401	OZAT-115 115	1.100	0.837	0.955	0.407	-0.548	-----

VAR
LIMIT

							GENERATORS ON VAR
21161	AHUA-U1 13.8	18.0	-10.0	9.9	18.0	8.1	+
21162	AHUA-U2 13.8	18.0	-10.0	9.9	18.0	8.1	+

S U M M A R Y O F F A I L E D C O N T I N G E N C I E S
(OVLVD> 1.00 RATEB, V.COLLAPSE<0.50, VOLT>1.10, VOLT<0.84, BUSES/ISLD>= 1)

CONTINGENCY 401 : BRANCH 1090 ++BRANCH 1056

----- POST-CONTINGENCY RESULTS -----

SOLN	OVERLOAD	DELT-FLOW	HIGH-VOLT	LOW-VOLT	SWING GEN	ITER	MM
-	0-0.00	0- 0.0	0-0.00	1-0.83	(37, 29)	4	0.07

OUTAGES FROM BUS TO BUS ID BASE CASE RATING-B P.U.-B

27431	SMAR-115 115	27461	STOM-115 115	1	83	266	0.31
27161	AHUA-115 115	27351	SANA-115 115	1	61	133	0.46

* AREA 2 * 0.7 0.9

1.1

VOLTAGE	BUS NAME	MAX.	MIN.	BASE	CONT	DEV.	*-----*
27471	PEDR-115 115	1.100	0.837	0.928	0.833	-0.095	-----

S U M M A R Y O F F A I L E D C O N T I N G E N C I E S
(OVLVD> 1.00 RATEB, V.COLLAPSE<0.50, VOLT>1.10, VOLT<0.84, BUSES/ISLD>= 1)

CONTINGENCY 427 : BRANCH 1090 ++BRANCH 1077

----- POST-CONTINGENCY RESULTS -----

SOLN	OVERLOAD	DELT-FLOW	HIGH-VOLT	LOW-VOLT	SWING GEN	ITER	MM
VC-	0-0.00	0- 0.0	0-0.00	7-0.74	(46, 29)	9	20.43

OUTAGES FROM BUS TO BUS ID BASE CASE RATING-B P.U.-B

27431	SMAR-115 115	27461	STOM-115 115	1	83	266	0.31
27361	SANT-115 115	27371	NEJA-115 115	1	69	266	0.26

* AREA 2 * 0.7 0.9

1.1

VOLTAGE	BUS NAME	MAX.	MIN.	BASE	CONT	DEV.	*-----*
22421	NCUS-23 23.0	1.100	0.837	0.987	0.806	-0.181	-----
24461	STOM-46 46.0	1.100	0.837	1.009	0.804	-0.205	-----
24471	PEDR-46 46.0	1.100	0.837	1.026	0.815	-0.211	-----
27361	SANT-115 115	1.100	0.837	0.955	0.803	-0.152	-----
27421	NCUS-115 115	1.100	0.837	0.940	0.777	-0.163	-----
27461	STOM-115 115	1.100	0.837	0.941	0.754	-0.187	-----
27471	PEDR-115 115	1.100	0.837	0.928	0.739	-0.189	-----

VAR
LIMIT

							GENERATORS ON VAR
20301	SOYA-G1 4.16	3.0	0.0	1.4	0.0	-1.4	-

S U M M A R Y O F F A I L E D C O N T I N G E N C I E S
(OVLVD> 1.00 RATEB, V.COLLAPSE<0.50, VOLT>1.10, VOLT<0.84, BUSES/ISLD>= 1)

CONTINGENCY 431 : BRANCH 1090 ++BRANCH 1085

----- POST-CONTINGENCY RESULTS -----

SOLN	OVERLOAD	DELT-FLOW	HIGH-VOLT	LOW-VOLT	SWING GEN	ITER	MM
-	0-0.00	0- 0.0	0-0.00	3-0.80	(38, 29)	4	0.06

OUTAGES FROM BUS TO BUS ID BASE CASE RATING-B P.U.-B

27431	SMAR-115 115	27461	STOM-115 115	1	83	266	0.31
27411	SONS-115 115	27441	ATEO-115 115	1	76	133	0.57

* AREA 2 * 0.7 0.9

1.1

VOLTAGE	BUS NAME	MAX.	MIN.	BASE	CONT	DEV.	*-----*
27421	NCUS-115 115	1.100	0.837	0.940	0.835	-0.105	-----

Escenario de demanda media del mes de marzo

27461	STOM-115	115	1.100	0.837	0.941	0.812	-0.129	.	-----	.
27471	PEDR-115	115	1.100	0.837	0.928	0.797	-0.131	.	-----	.

S U M M A R Y O F F A I L E D C O N T I N G E N C I E S
(OVLDT> 1.00 RATEB, V.COLLAPSE<0.50, VOLT>1.10, VOLT<0.84, BUSES/ISLD>= 1)

CONTINGENCY 434 : BRANCH 1090 ++BRANCH 1054

----- POST-CONTINGENCY RESULTS -----										
SOLN	OVERLOAD	DELT-FLOW	HIGH-VOLT	LOW-VOLT	SWING	GEN	ITER	MM		
-	0-0.00	0-	0.0	0-0.00	1-0.84	(34, 28)	2	0.03	

OUTAGES	FROM BUS	TO BUS	ID	BASE	CASE	RATING-B	P.U.-B		
27431	SMAR-115	115	27461	STOM-115	115	1	83	266	0.31
27131	ACAJ-115	115	27411	SONS-115	115	2	68	133	0.51

* AREA 2 * 0.7 0.9

1.1

VOLTAGE	BUS NAME	MAX.	MIN.	BASE	CONT	DEV.	*-----*	
27471	PEDR-115	115	1.100	0.837	0.928	0.836	-0.092	. ----- .

S U M M A R Y O F F A I L E D C O N T I N G E N C I E S
(OVLDT> 1.00 RATEB, V.COLLAPSE<0.50, VOLT>1.10, VOLT<0.84, BUSES/ISLD>= 1)

CONTINGENCY 435 : BRANCH 1090 ++BRANCH 1053

----- POST-CONTINGENCY RESULTS -----										
SOLN	OVERLOAD	DELT-FLOW	HIGH-VOLT	LOW-VOLT	SWING	GEN	ITER	MM		
-	0-0.00	0-	0.0	0-0.00	1-0.84	(35, 28)	2	0.06	

OUTAGES	FROM BUS	TO BUS	ID	BASE	CASE	RATING-B	P.U.-B		
27431	SMAR-115	115	27461	STOM-115	115	1	83	266	0.31
27131	ACAJ-115	115	27411	SONS-115	115	1	68	133	0.51

* AREA 2 * 0.7 0.9

1.1

VOLTAGE	BUS NAME	MAX.	MIN.	BASE	CONT	DEV.	*-----*	
27471	PEDR-115	115	1.100	0.837	0.928	0.836	-0.092	. ----- .

S U M M A R Y O F F A I L E D C O N T I N G E N C I E S
(OVLDT> 1.00 RATEB, V.COLLAPSE<0.50, VOLT>1.10, VOLT<0.84, BUSES/ISLD>= 1)

CONTINGENCY 655 : BRANCH 1090 ++BRANCH 1057

----- POST-CONTINGENCY RESULTS -----										
SOLN	OVERLOAD	DELT-FLOW	HIGH-VOLT	LOW-VOLT	SWING	GEN	ITER	MM		
-	0-0.00	0-	0.0	0-0.00	1-0.83	(34, 28)	5	0.09	

OUTAGES	FROM BUS	TO BUS	ID	BASE	CASE	RATING-B	P.U.-B		
27431	SMAR-115	115	27461	STOM-115	115	1	83	266	0.31
27161	AHUA-115	115	27411	SONS-115	115	1	12	133	0.09

* AREA 2 * 0.7 0.9

1.1

VOLTAGE	BUS NAME	MAX.	MIN.	BASE	CONT	DEV.	*-----*	
27471	PEDR-115	115	1.100	0.837	0.928	0.834	-0.094	. ----- .

S U M M A R Y O F F A I L E D C O N T I N G E N C I E S
(OVLDT> 1.00 RATEB, V.COLLAPSE<0.50, VOLT>1.10, VOLT<0.84, BUSES/ISLD>= 1)

CONTINGENCY 671 : BRANCH 1073 ++BRANCH 1070

----- POST-CONTINGENCY RESULTS -----										
SOLN	OVERLOAD	DELT-FLOW	HIGH-VOLT	LOW-VOLT	SWING	GEN	ITER	MM		
-	1-1.19	0-	0.0	0-0.00	6-0.68	(52, 30)	4	0.11	

OUTAGES	FROM BUS	TO BUS	ID	BASE	CASE	RATING-B	P.U.-B		
27321	SRAF-115	115	27391	TECO-115	115	1	18	133	0.13
27211	BERL-115	115	27341	SMIG-115	115	1	62	133	0.47

OVERLOAD	FROM BUS	TO BUS	ID	BASE	CONT	---P.U.	FLWS---
27181	15SE-115	115	27341	SMIG-115	115	1	37 158 1.40 1.19 1.19

* AREA 2 * 0.7 0.9

1.1

VOLTAGE	BUS NAME	MAX.	MIN.	BASE	CONT	DEV.	*-----*
24341	SMIG-46 46.0	1.100	0.837	1.016	0.765	-0.251	.-----.
24391	TECO-46 46.0	1.100	0.837	1.003	0.705	-0.298	.-----.
24401	OZAT-46 46.0	1.100	0.837	1.008	0.730	-0.278	.-----.
27341	SMIG-115 115	1.100	0.837	0.964	0.744	-0.220	.-----.
27391	TECO-115 115	1.100	0.837	0.959	0.682	-0.277	.-----.
27401	OZAT-115 115	1.100	0.837	0.955	0.700	-0.255	.-----.

VAR LIMIT GENERATORS ON VAR

S U M M A R Y O F F A I L E D C O N T I N G E N C I E S
(OVLD> 1.00 RATEB, V.COLLAPSE<0.50, VOLT>1.10, VOLT<0.84, BUSES/ISLD>= 1)

CONTINGENCY 832 : BRANCH 1084 ++BRANCH 1070

----- POST-CONTINGENCY RESULTS -----

SOLN	OVERLOAD	DELT-FLOW	HIGH-VOLT	LOW-VOLT	SWING GEN	ITER	MM
-	0-0.00	0- 0.0	0-0.00	2-0.80	(41, 29)	3	0.05

OUTAGES	FROM BUS	TO BUS	ID	BASE CASE	RATING-B	P.U.-B
27391	TECO-115 115	27401 OZAT-115 115	1	4	133	0.03
27211	BERL-115 115	27341 SMIG-115 115	1	62	133	0.47

* AREA 2 * 0.7 0.9

1.1

VOLTAGE	BUS NAME	MAX.	MIN.	BASE	CONT	DEV.	*-----*
27341	SMIG-115 115	1.100	0.837	0.964	0.819	-0.145	.-----.
27401	OZAT-115 115	1.100	0.837	0.955	0.800	-0.155	.-----.

El resumen de los resultados se presenta en la siguiente tabla:

Cuadro 1 – Voltaje en p.u. de barras con violaciones de voltaje (0.837 p.u.).

CONTINGENCIAS N-2 HOND->ELSA 80 MW DEM- MEDIA, MARZO	Barras con Violaciones de Voltaje						
	SMIG -115	TECO -115	OZAT -115	NCUS -115	STOM -115	PEDR -115	SANT -115
SMAR-STOM & ATEO-GM						0.833	
SMAR-STOM & 15SE-U1						0.836	
SMAR-STOM & CGRA-U1						0.830	
SMAR-STOM & ACAJ-U5					0.834	0.819	
SMAR-STOM & ACAJ-ATEO				0.821	0.797	0.782	
NCUS-ATEO & SANT-ATEO				0.822		0.832	
SMAR-STOM & AHUA-SANA						0.833	
SMAR-STOM & AHUA-SONS						0.834	
BERL-SMIG & 15SE-SMIG	V.C.	V.C.	V.C.	V.C.	V.C.	V.C.	V.C.
SRAF-TECO & BERL-SMIG	0.744*	0.682*	0.700*				
TECO-OZAT & BERL-SMIG	0.819		0.800				
SMAR-STOM & SANT-NEJA	V.C.	V.C.	V.C.	V.C.	V.C.	V.C.	V.C.
SMAR-STOM & ACAJ-SONS						0.836	
SMAR-STOM & SONS-ATEO				0.835	0.812	0.797	

Nota: (*) significa que también hay bajo voltaje en el secundario del transformador.

3.2.5. Caso E: Máxima transferencia El Salvador--> Honduras 91 MW

Archivo: MM_EH91.raw (versión 26 convertida de MM_EH91.sav)

Con el objeto de evitar el analizar los casos menos críticos, primeramente se hizo un análisis de la cantidad de casos de contingencias N-2 que se producen en función del límites inferior de voltaje para el cual se considera un abatimiento del voltaje extremo:

Límite inferior de voltaje en nodos (p.u.)	Número de casos con violación del límite inferior de voltaje	Número de casos con colapso de voltaje y de no-convergencia
0.90	156	2
0.89	86	2
0.88	75	2
0.87	71	2
0.86	71	2
0.85	69	2
0.84	16	2

Del cuadro anterior, se concluye que dos casos de “colapso de voltaje”, que son una constante en todos los escenarios posibles; y que además, como punto de partida, se analizarán los 16 casos críticos de bajo voltaje con respecto a la violación de límite inferior de 0.84 p.u. de voltaje, cuyos resultados se muestran a continuación:

```

*** CONTINGENCY RESULTS SUMMARY ***

TOTAL NO. OF CONTINGENCIES TESTED      =    986
I.   CONVERGED CONTINGENCIES            =    984
II.  VOLTAGE COLLAPSE CONTINGENCIES     =     2
III. NOT CONVERGED CONTINGENCIES        =     0

*** FAILURE SUMMARY ***

FAILURE CRITERIA                        NO. OF   WORST   CASE
-----                                FAILURES INDEX   VALUE
I.   CONVERGED ( 984 CONTINGENCIES) :
      AT LEAST ( 1) BUSES PER ISLAND      0         0 ( 0)
      OVERLOAD ABOVE (1.00) PU OF RATING (B) 29        390 ( 1.58)
      CHANGE IN FLOW ABOVE (999.0%)        0         0 ( 0.0)
      BUS VOLTAGE ABOVE ( 1.10) P.U.       0         0 ( 0.00)
      BUS VOLTAGE BELOW ( 0.84) P.U.       16        481 ( 0.70)
      SUBTOTAL                            43
II.  VOLTAGE COLLAPSE:                    2
III. NOT-CONVERGED (MM > 0.10)           0

TOTAL FAILED CONTINGENCIES :              45
(OFT OF 986 CONTINGENCIES TESTED)

```

Los resultados indican lo siguiente:

- El TPLAN realizó 986 contingencias de líneas de transmisión y de generación.
- 16 casos de contingencias presentan violación del límite inferior de voltaje (0.89 p.u.).
- Hay 29 casos de violación por sobrecarga de líneas de transmisión, los cuales no son objeto del presente estudio.
- Hay 2 casos de colapso de voltaje.

Un resumen detallado de los casos de bajo voltaje se muestra a continuación:

S U M M A R Y O F F A I L E D C O N T I N G E N C I E S
(OVLD> 1.00 RATEB, V.COLLAPSE<0.50, VOLT>1.10, VOLT<0.84, BUSES/ISLD>= 1)

CONTINGENCY 81 : BRANCH 1093 ++UNIT 338

----- POST-CONTINGENCY RESULTS -----
SOLN OVERLOAD DELT-FLOW HIGH-VOLT LOW-VOLT SWING GEN ITER MM
- 0-0.00 0- 0.0 0-0.00 1-0.84 (42, 28) 4 0.06

OUTAGES FROM BUS TO BUS ID BASE CASE RATING-B P.U.-B
27431 SMAR-115 115 27461 STOM-115 115 1 79 266 0.30
21441 ATEO-GM 13.8 1 16 17

* AREA 2 * 0.7 0.9 1.1
VOLTAGE BUS NAME MAX. MIN. BASE CONT DEV. *-----*-----*-----*
27471 PEDR-115 1.100 0.840 0.935 0.836 -0.099 . ----- .

S U M M A R Y O F F A I L E D C O N T I N G E N C I E S
(OVLD> 1.00 RATEB, V.COLLAPSE<0.50, VOLT>1.10, VOLT<0.84, BUSES/ISLD>= 1)

CONTINGENCY 311 : BRANCH 1093 ++UNIT 302

----- POST-CONTINGENCY RESULTS -----
SOLN OVERLOAD DELT-FLOW HIGH-VOLT LOW-VOLT SWING GEN ITER MM
- 0-0.00 0- 0.0 0-0.00 1-0.84 (42, 28) 4 0.02

OUTAGES FROM BUS TO BUS ID BASE CASE RATING-B P.U.-B
27431 SMAR-115 115 27461 STOM-115 115 1 79 266 0.30
21172 CGRA-U2 13.8 2 68 68

* AREA 2 * 0.7 0.9 1.1
VOLTAGE BUS NAME MAX. MIN. BASE CONT DEV. *-----*-----*-----*
27471 PEDR-115 1.100 0.840 0.935 0.838 -0.097 . ----- .

S U M M A R Y O F F A I L E D C O N T I N G E N C I E S
(OVLD> 1.00 RATEB, V.COLLAPSE<0.50, VOLT>1.10, VOLT<0.84, BUSES/ISLD>= 1)

CONTINGENCY 331 : BRANCH 1093 ++UNIT 301

----- POST-CONTINGENCY RESULTS -----
SOLN OVERLOAD DELT-FLOW HIGH-VOLT LOW-VOLT SWING GEN ITER MM
- 0-0.00 0- 0.0 0-0.00 1-0.84 (42, 28) 4 0.03

OUTAGES FROM BUS TO BUS ID BASE CASE RATING-B P.U.-B
27431 SMAR-115 115 27461 STOM-115 115 1 79 266 0.30
21171 CGRA-U1 13.8 1 68 68

* AREA 2 * 0.7 0.9 1.1
VOLTAGE BUS NAME MAX. MIN. BASE CONT DEV. *-----*-----*-----*
27471 PEDR-115 1.100 0.840 0.935 0.838 -0.097 . ----- .

S U M M A R Y O F F A I L E D C O N T I N G E N C I E S
(OVLD> 1.00 RATEB, V.COLLAPSE<0.50, VOLT>1.10, VOLT<0.84, BUSES/ISLD>= 1)

CONTINGENCY 380 : BRANCH 1093 ++UNIT 287

----- POST-CONTINGENCY RESULTS -----
SOLN OVERLOAD DELT-FLOW HIGH-VOLT LOW-VOLT SWING GEN ITER MM
- 0-0.00 0- 0.0 0-0.00 1-0.83 (40, 28) 4 0.05

OUTAGES FROM BUS TO BUS ID BASE CASE RATING-B P.U.-B
27431 SMAR-115 115 27461 STOM-115 115 1 79 266 0.30
21135 ACAJ-U5 13.8 5 57 65

* AREA 2 * 0.7 0.9 1.1
VOLTAGE BUS NAME MAX. MIN. BASE CONT DEV. *-----*-----*-----*
27471 PEDR-115 1.100 0.840 0.935 0.827 -0.108 . ----- .

S U M M A R Y O F F A I L E D C O N T I N G E N C I E S
(OVLD> 1.00 RATEB, V.COLLAPSE<0.50, VOLT>1.10, VOLT<0.84, BUSES/ISLD>= 1)

CONTINGENCY 401 : BRANCH 1093 ++BRANCH 1057

----- POST-CONTINGENCY RESULTS -----
SOLN OVERLOAD DELT-FLOW HIGH-VOLT LOW-VOLT SWING GEN ITER MM
- 1-1.23 0- 0.0 0-0.00 3-0.79 (51, 29) 4 0.10

OUTAGES FROM BUS TO BUS ID BASE CASE RATING-B P.U.-B
27431 SMAR-115 115 27461 STOM-115 115 1 79 266 0.30
27131 ACAJ-115 115 27441 ATEO-115 115 1 90 266 0.34

OVERLOAD FROM BUS TO BUS ID BASE CONT ---P.U. FLOWS---
27411 SONS-115 115 27441 ATEO-115 115 1 76 164 1.45 1.23 1.23

* AREA 2 * 0.7 0.9 1.1
VOLTAGE BUS NAME MAX. MIN. BASE CONT DEV. *-----*-----*-----*
27421 NCUS-115 1.100 0.840 0.946 0.830 -0.116 . - - - - .
27461 STOM-115 1.100 0.840 0.948 0.806 -0.142 . - - - - .
27471 PEDR-115 1.100 0.840 0.935 0.791 -0.144 . - - - - .

S U M M A R Y O F F A I L E D C O N T I N G E N C I E S
(OVLD> 1.00 RATEB, V.COLLAPSE<0.50, VOLT>1.10, VOLT<0.84, BUSES/ISLD>= 1)

CONTINGENCY 476 : BRANCH 1072 ++BRANCH 1067

----- POST-CONTINGENCY RESULTS -----
SOLN OVERLOAD DELT-FLOW HIGH-VOLT LOW-VOLT SWING GEN ITER MM
VC- 3-1.67 0- 0.0 0-0.00 6-0.00 (9, 30) 9 0.08

OUTAGES FROM BUS TO BUS ID BASE CASE RATING-B P.U.-B
27211 BERL-115 115 27341 SMIG-115 115 1 57 133 0.43
27181 15SE-115 115 27341 SMIG-115 115 1 33 133 0.25

OVERLOAD FROM BUS TO BUS ID BASE CONT ---P.U. FLOWS---
27321 SRAF-115 115 27391 TECO-115 115 1 27 222 1.96 1.67 1.67
27341 SMIG-115 115 27401 OZAT-115 115 1 9 187 1.65 1.41 1.41
27391 TECO-115 115 27401 OZAT-115 115 1 11 207 1.83 1.56 1.56

* AREA 2 * 0.7 0.9 1.1
VOLTAGE BUS NAME MAX. MIN. BASE CONT DEV. *-----*-----*-----*
24341 SMIG-46 4 1.100 0.840 1.020 0.000 -1.020 - - - - .
24391 TECO-46 4 1.100 0.840 1.011 0.692 -0.319 - - - - .
24401 OZAT-46 4 1.100 0.840 1.014 0.430 -0.584 - - - - .
27341 SMIG-115 1.100 0.840 0.968 0.171 -0.797 - - - - .
27391 TECO-115 1.100 0.840 0.966 0.670 -0.296 - - - - .
27401 OZAT-115 1.100 0.840 0.960 0.425 -0.535 - - - - .

VAR 21101 5NOV-U1 1 7.0 0.0 5.3 7.0 1.7 GENERATORS ON VAR LIMIT +

S U M M A R Y O F F A I L E D C O N T I N G E N C I E S
(OVLD> 1.00 RATEB, V.COLLAPSE<0.50, VOLT>1.10, VOLT<0.84, BUSES/ISLD>= 1)

CONTINGENCY 481 : BRANCH 1076 ++BRANCH 1072

----- POST-CONTINGENCY RESULTS -----
SOLN OVERLOAD DELT-FLOW HIGH-VOLT LOW-VOLT SWING GEN ITER MM
- 1-1.15 0- 0.0 0-0.00 6-0.70 (57, 30) 3 0.09

OUTAGES FROM BUS TO BUS ID BASE CASE RATING-B P.U.-B
27321 SRAF-115 115 27391 TECO-115 115 1 27 133 0.20
27211 BERL-115 115 27341 SMIG-115 115 1 57 133 0.43

OVERLOAD FROM BUS TO BUS ID BASE CONT ---P.U. FLOWS---
27181 15SE-115 115 27341 SMIG-115 115 1 33 153 1.35 1.15 1.15

* AREA	2 *						0.7	0.9	1.1
VOLTAGE	BUS NAME	MAX.	MIN.	BASE	CONT	DEV.	*-----*	*-----*	*-----*
24341	SMIG-46 4	1.100	0.840	1.020	0.787	-0.233	.	-----	.
24391	TECO-46 4	1.100	0.840	1.011	0.728	-0.283	.	-----	.
24401	OZAT-46 4	1.100	0.840	1.014	0.752	-0.262	.	-----	.
27341	SMIG-115	1.100	0.840	0.968	0.763	-0.205	.	-----	.
27391	TECO-115	1.100	0.840	0.966	0.703	-0.263	.	-----	.
27401	OZAT-115	1.100	0.840	0.960	0.720	-0.240	.	-----	.

S U M M A R Y O F F A I L E D C O N T I N G E N C I E S
(OVLD> 1.00 RATEB, V.COLLAPSE<0.50, VOLT>1.10, VOLT<0.84, BUSES/ISLD>= 1)

CONTINGENCY 493 : BRANCH 1093 ++BRANCH 1058

POST-CONTINGENCY RESULTS							
SOLN	OVERLOAD	DELT-FLOW	HIGH-VOLT	LOW-VOLT	SWING	GEN ITER	MM
-	0-0.00	0- 0.0	0-0.00	1-0.84	(44, 29)	4	0.05

OUTAGES	FROM BUS	TO BUS	ID	BASE	CASE	RATING-B	P.U.-B
27431	SMAR-115 115	27461 STOM-115 115	1	79	266	0.30	
27161	AHUA-115 115	27351 SANA-115 115	1	55	133	0.42	

* AREA	2 *						0.7	0.9	1.1
VOLTAGE	BUS NAME	MAX.	MIN.	BASE	CONT	DEV.	*-----*	*-----*	*-----*
27471	PEDR-115	1.100	0.840	0.935	0.837	-0.098	.	-----	.

S U M M A R Y O F F A I L E D C O N T I N G E N C I E S
(OVLD> 1.00 RATEB, V.COLLAPSE<0.50, VOLT>1.10, VOLT<0.84, BUSES/ISLD>= 1)

CONTINGENCY 513 : BRANCH 1093 ++BRANCH 1080

POST-CONTINGENCY RESULTS							
SOLN	OVERLOAD	DELT-FLOW	HIGH-VOLT	LOW-VOLT	SWING	GEN ITER	MM
VC-	0-0.00	0- 0.0	0-0.00	12-0.64	(51, 29)	2	35.58

OUTAGES	FROM BUS	TO BUS	ID	BASE	CASE	RATING-B	P.U.-B
27431	SMAR-115 115	27461 STOM-115 115	1	79	266	0.30	
27361	SANT-115 115	27371 NEJA-115 115	1	72	266	0.27	

* AREA	2 *						0.7	0.9	1.1
VOLTAGE	BUS NAME	MAX.	MIN.	BASE	CONT	DEV.	*-----*	*-----*	*-----*
21441	ATEO-GM 1	1.100	0.840	1.015	0.804	-0.211	.	-----	.
22361	SANT-23 2	1.100	0.840	1.005	0.737	-0.268	.	-----	.
22421	NCUS-23 2	1.100	0.840	0.994	0.701	-0.293	.	-----	.
23441	ATEO-34 3	1.100	0.840	1.006	0.786	-0.220	.	-----	.
24441	ATEO-46 4	1.100	0.840	1.019	0.798	-0.221	.	-----	.
24461	STOM-46 4	1.100	0.840	1.017	0.699	-0.318	.	-----	.
24471	PEDR-46 4	1.100	0.840	1.021	0.695	-0.326	.	-----	.
27361	SANT-115	1.100	0.840	0.962	0.718	-0.244	.	-----	.
27421	NCUS-115	1.100	0.840	0.946	0.685	-0.261	.	-----	.
27441	ATEO-115	1.100	0.840	0.969	0.759	-0.210	.	-----	.
27461	STOM-115	1.100	0.840	0.948	0.659	-0.289	.	-----	.
27471	PEDR-115	1.100	0.840	0.935	0.642	-0.293	.	-----	.

S U M M A R Y O F F A I L E D C O N T I N G E N C I E S
(OVLD> 1.00 RATEB, V.COLLAPSE<0.50, VOLT>1.10, VOLT<0.84, BUSES/ISLD>= 1)

CONTINGENCY 514 : BRANCH 1093 ++BRANCH 1088

POST-CONTINGENCY RESULTS							
SOLN	OVERLOAD	DELT-FLOW	HIGH-VOLT	LOW-VOLT	SWING	GEN ITER	MM
-	0-0.00	0- 0.0	0-0.00	2-0.80	(45, 29)	5	0.06

OUTAGES	FROM BUS	TO BUS	ID	BASE	CASE	RATING-B	P.U.-B
27431	SMAR-115 115	27461 STOM-115 115	1	79	266	0.30	
27411	SONS-115 115	27441 ATEO-115 115	1	76	133	0.57	

* AREA	2 *						0.7	0.9	1.1
VOLTAGE	BUS NAME	MAX.	MIN.	BASE	CONT	DEV.	*-----*	*-----*	*-----*
27461	STOM-115	1.100	0.840	0.948	0.817	-0.131	.	-----	.
27471	PEDR-115	1.100	0.840	0.935	0.802	-0.133	.	-----	.

S U M M A R Y O F F A I L E D C O N T I N G E N C I E S
(OVLD> 1.00 RATEB, V.COLLAPSE<0.50, VOLT>1.10, VOLT<0.84, BUSES/ISLD>= 1)

CONTINGENCY 516 : BRANCH 1093 ++BRANCH 1055

```

----- POST-CONTINGENCY RESULTS -----
SOLN   OVERLOAD DELT-FLOW HIGH-VOLT  LOW-VOLT  SWING GEN ITER   MM
-       0-0.00   0- 0.0   0-0.00   1-0.84   ( 42, 29)  2   0.08

OUTAGES FROM BUS           TO BUS           ID  BASE CASE  RATING-B  P.U.-B
27431 SMAR-115 115 27461 STOM-115 115 1    79    266    0.30
27131 ACAJ-115 115 27411 SONS-115 115 1    64    133    0.48

* AREA 2 *
VOLTAGE BUS NAME    MAX.    MIN.    BASE    CONT    DEV.    0.7    0.9    1.1
27471 PEDR-115    1.100  0.840  0.935  0.839  -0.096  .      -      .

```

S U M M A R Y O F F A I L E D C O N T I N G E N C I E S
(OVLD> 1.00 RATEB, V.COLLAPSE<0.50, VOLT>1.10, VOLT<0.84, BUSES/ISLD>= 1)

CONTINGENCY 517 : BRANCH 1093 ++BRANCH 1063

```

----- POST-CONTINGENCY RESULTS -----
SOLN   OVERLOAD DELT-FLOW HIGH-VOLT  LOW-VOLT  SWING GEN ITER   MM
-       0-0.00   0- 0.0   0-0.00   1-0.84   ( 42, 29)  2   0.09

OUTAGES FROM BUS           TO BUS           ID  BASE CASE  RATING-B  P.U.-B
27431 SMAR-115 115 27461 STOM-115 115 1    79    266    0.30
27171 CGRA-115 115 27371 NEJA-115 115 1    56    266    0.21

* AREA 2 *
VOLTAGE BUS NAME    MAX.    MIN.    BASE    CONT    DEV.    0.7    0.9    1.1
27471 PEDR-115    1.100  0.840  0.935  0.838  -0.097  .      -      .

```

S U M M A R Y O F F A I L E D C O N T I N G E N C I E S
(OVLD> 1.00 RATEB, V.COLLAPSE<0.50, VOLT>1.10, VOLT<0.84, BUSES/ISLD>= 1)

CONTINGENCY 518 : BRANCH 1093 ++BRANCH 1064

```

----- POST-CONTINGENCY RESULTS -----
SOLN   OVERLOAD DELT-FLOW HIGH-VOLT  LOW-VOLT  SWING GEN ITER   MM
-       0-0.00   0- 0.0   0-0.00   1-0.84   ( 42, 29)  2   0.09

OUTAGES FROM BUS           TO BUS           ID  BASE CASE  RATING-B  P.U.-B
27431 SMAR-115 115 27461 STOM-115 115 1    79    266    0.30
27171 CGRA-115 115 27371 NEJA-115 115 2    56    266    0.21

* AREA 2 *
VOLTAGE BUS NAME    MAX.    MIN.    BASE    CONT    DEV.    0.7    0.9    1.1
27471 PEDR-115    1.100  0.840  0.935  0.838  -0.097  .      -      .

```

S U M M A R Y O F F A I L E D C O N T I N G E N C I E S
(OVLD> 1.00 RATEB, V.COLLAPSE<0.50, VOLT>1.10, VOLT<0.84, BUSES/ISLD>= 1)

CONTINGENCY 682 : BRANCH 1076 ++BRANCH 1067

```

----- POST-CONTINGENCY RESULTS -----
SOLN   OVERLOAD DELT-FLOW HIGH-VOLT  LOW-VOLT  SWING GEN ITER   MM
-       0-0.00   0- 0.0   0-0.00   1-0.83   ( 42, 29)  3   0.03

OUTAGES FROM BUS           TO BUS           ID  BASE CASE  RATING-B  P.U.-B
27321 SRAF-115 115 27391 TECO-115 115 1    27    133    0.20
27181 15SE-115 115 27341 SMIG-115 115 1    33    133    0.25

```

Escenario de demanda media del mes de marzo

```
* AREA      2 *
VOLTAGE BUS NAME      MAX.      MIN.      BASE      CONT      DEV.      0.7      0.9      1.1
      27391 TECO-115    1.100    0.840    0.966    0.830    -0.136    .      -----    .
VAR
GENERATORS ON VAR LIMIT
```

S U M M A R Y O F F A I L E D C O N T I N G E N C I E S
(OVLD> 1.00 RATEB, V.COLLAPSE<0.50, VOLT>1.10, VOLT<0.84, BUSES/ISLD>= 1)

CONTINGENCY 716 : BRANCH 1093 ++BRANCH 1077

```
----- POST-CONTINGENCY RESULTS -----
SOLN  OVERLOAD DELT-FLOW HIGH-VOLT  LOW-VOLT  SWING GEN ITER  MM
      -      0-0.00  0- 0.0  0-0.00  1-0.84  ( 42, 29)  4  0.05

OUTAGES FROM BUS      TO BUS      ID  BASE CASE  RATING-B  P.U.-B
      27431 SMAR-115 115 27461 STOM-115 115 1      79      266      0.30
      27321 SRAF-115 115 27431 SMAR-115 115 1      60      266      0.22
```

```
* AREA      2 *
VOLTAGE BUS NAME      MAX.      MIN.      BASE      CONT      DEV.      0.7      0.9      1.1
      27471 PEDR-115    1.100    0.840    0.935    0.839    -0.096    .      -----    .
```

S U M M A R Y O F F A I L E D C O N T I N G E N C I E S
(OVLD> 1.00 RATEB, V.COLLAPSE<0.50, VOLT>1.10, VOLT<0.84, BUSES/ISLD>= 1)

CONTINGENCY 744 : BRANCH 1093 ++BRANCH 1059

```
----- POST-CONTINGENCY RESULTS -----
SOLN  OVERLOAD DELT-FLOW HIGH-VOLT  LOW-VOLT  SWING GEN ITER  MM
      -      0-0.00  0- 0.0  0-0.00  1-0.84  ( 42, 29)  4  0.09

OUTAGES FROM BUS      TO BUS      ID  BASE CASE  RATING-B  P.U.-B
      27431 SMAR-115 115 27461 STOM-115 115 1      79      266      0.30
      27161 AHUA-115 115 27411 SONS-115 115 1      15      133      0.11
```

```
* AREA      2 *
VOLTAGE BUS NAME      MAX.      MIN.      BASE      CONT      DEV.      0.7      0.9      1.1
      27471 PEDR-115    1.100    0.840    0.935    0.835    -0.100    .      -----    .
```

S U M M A R Y O F F A I L E D C O N T I N G E N C I E S
(OVLD> 1.00 RATEB, V.COLLAPSE<0.50, VOLT>1.10, VOLT<0.84, BUSES/ISLD>= 1)

CONTINGENCY 806 : BRANCH 1093 ++BRANCH 1082

```
----- POST-CONTINGENCY RESULTS -----
SOLN  OVERLOAD DELT-FLOW HIGH-VOLT  LOW-VOLT  SWING GEN ITER  MM
      -      0-0.00  0- 0.0  0-0.00  1-0.84  ( 42, 29)  4  0.02

OUTAGES FROM BUS      TO BUS      ID  BASE CASE  RATING-B  P.U.-B
      27431 SMAR-115 115 27461 STOM-115 115 1      79      266      0.30
      27371 NEJA-115 115 27381 OPIC-115 115 1      48      266      0.18
```

```
* AREA      2 *
VOLTAGE BUS NAME      MAX.      MIN.      BASE      CONT      DEV.      0.7      0.9      1.1
      27471 PEDR-115    1.100    0.840    0.935    0.839    -0.096    .      -----    .
```

S U M M A R Y O F F A I L E D C O N T I N G E N C I E S
(OVLD> 1.00 RATEB, V.COLLAPSE<0.50, VOLT>1.10, VOLT<0.84, BUSES/ISLD>= 1)

CONTINGENCY 909 : BRANCH 1087 ++BRANCH 1072

```
----- POST-CONTINGENCY RESULTS -----
SOLN  OVERLOAD DELT-FLOW HIGH-VOLT  LOW-VOLT  SWING GEN ITER  MM
      -      0-0.00  0- 0.0  0-0.00  2-0.81  ( 48, 29)  3  0.09

OUTAGES FROM BUS      TO BUS      ID  BASE CASE  RATING-B  P.U.-B
      27391 TECO-115 115 27401 OZAT-115 115 1      11      133      0.08
      27211 BERL-115 115 27341 SMIG-115 115 1      57      133      0.43
```

VOLTAGE	BUS NAME	MAX.	MIN.	BASE	CONT	DEV.	0.7	0.9	1.1
27341	SMIG-115	1.100	0.840	0.968	0.826	-0.142	.	-----	.
27401	OZAT-115	1.100	0.840	0.960	0.807	-0.153	.	-----	.

El resumen de los resultados se presenta en la siguiente tabla:

Cuadro 1 – Voltaje en p.u. de barras con violaciones de voltaje (0.84 p.u.).

CONTINGENCIAS N-2 ELSA->HOND 91 MW DEM. MEDIA, MARZO	Barras con Violaciones de Voltaje							
	SMIG -115	TECO -115	OZAT -115	NCUS -115	STOM -115	PEDR -115	SANT -115	
SMAR-STOM & ATEO-GM						0.836		
SMAR-STOM & NEJA-OPIC						0.839		
SMAR-STOM & CGRA-U1						0.838		
SMAR-STOM & ACAJ-U5						0.827		
SMAR-STOM & ACAJ-ATEO				0.830	0.806	0.791		
SMAR-STOM & CGRA-NEJA						0.838		
SMAR-STOM & SRAF-SMAR						0.839		
SMAR-STOM & AHUA-SANA						0.837		
SMAR-STOM & AHUA-SONS						0.835		
BERL-SMIG & 15SE-SMIG	V.C.	V.C.	V.C.	V.C.	V.C.	V.C.	V.C.	
SRAF-TECO & BERL-SMIG	0.763*	0.703*	0.720*					
TECO-OZAT & BERL-SMIG	0.826		0.807					
SRAF-TECO & 15SE-SMIG		0.830						
SMAR-STOM & SANT-NEJA	V.C.	V.C.	V.C.	V.C.	V.C.	V.C.	V.C.	
SMAR-STOM & ACAJ-SONS						0.839		
SMAR-STOM & SONS-ATEO					0.817	0.802		

Nota: (*) significa que también hay bajo voltaje en el secundario del transformador.

3.3. Resultados y conclusiones:

a. Un cuadro resumen de resultados para las contingencias N-1 es el siguiente:

CONTINGENCIAS N-1	NODO 115 KV	caso base	G->E 40	E->G 106	H->E 80	E->H 91
BERL-SMIG	SMIG	0.893	0.891		0.889	
SRAF-TECO	TECO	0.897	0.896			
SANT-NEJA	SANT		0.898			
NCUS-ATEO	NCUS	0.888	0.886	0.895	0.883	0.894
	PEDR	0.896	0.893		0.891	
SMAR-STOM	NCUS	0.877	0.871	0.881	0.876	0.879
	STOM	0.855	0.848	0.859	0.854	0.858
	PEDR	0.841	0.834	0.845	0.840	0.843

b. Un cuadro resumen de resultados para las contingencias N-2 es el siguiente:

CONTINGENCIAS N-2	NODO 115 KV	caso base	G->E 40	E->G 106	H->E 80	E->H 91
BERL-SMIG & 15SE-SMIG		V.C.	V.C.	V.C.	N.C.	N.C.
SMAR-STOM & CGRA-U1	PEDR	0.835	0.827	0.840	0.830	0.838
SMAR-STOM & ACAJ-U5	PEDR		0.807	0.829	0.819	0.827
SMAR-STOM & ATEO-GM	PEDR	0.819	0.826	0.838	0.833	0.836
SMAR-STOM & 15SE-U1	PEDR				0.836	
BERL-SMIG & 15SE-U1	SMIG	0.833	0.828			
BERL-SMIG & CGRA-U1	SMIG		0.827			
SANT-NEJA & ACAJ-ATEO	SANT	0.835				
SMAR-STOM & ACAJ-ATEO	NCUS	0.823	0.821	0.833	0.821	0.830
	STOM	0.799	0.797	0.810	0.797	0.806
	PEDR	0.783	0.781	0.794	0.782	0.791
SMAR-STOM & SRAF-SMAR	PEDR			0.841		0.839
SMAR-STOM & NEJA-OPIC						0.839
SMAR-STOM & AHUA-SANA	PEDR	0.837	0.822		0.833	0.837
NCUS-ATEO & SANT-ATEO	NCUS		0.828		0.822	
SMAR-STOM & AHUA-SONS	PEDR	0.838	0.823	0.837	0.834	0.835
SMAR-STOM & SANT-NEJA		V.C.	V.C.	V.C.	V.C.	V.C.
SMAR-STOM & CGRA-NEJA	PEDR		0.829	0.840		0.838
SMAR-STOM & ACAJ-SONS	PEDR			0.841	0.836	0.839
SMAR-STOM & SONS-ATEO	STOM	0.813	0.806	0.821	0.812	0.817
	PEDR	0.798	0.791	0.806	0.797	0.802
SMAR-STOM & 15SE-SMAR	STOM			0.841		
SRAF-TECO & 15SE-SMIG	TECO	0.813	0.810	0.837		0.830
	OZAT	0.827	0.824			
SMAR-STOM & SANT-ATEO	NCUS			0.840		
	STOM			0.816		
	PEDR			0.801		
SRAF-TECO & BERL-SMIG	SMIG	0.726*	0.722*	0.770*	0.744*	0.763*
	TECO	0.661*	0.657*	0.711*	0.682*	0.703*
	OZAT	0.679*	0.675*	0.728*	0.700*	0.720*
TECO-OZAT & BERL-SMIG	SMIG	0.807	0.805	0.830	0.819	0.826
	OZAT	0.788	0.786	0.811	0.800	0.807

- c. Los nodos afectados (de mayor a menor) por bajo voltaje son: PEDR, SMIG, STOM, OZAT, TECO, NCUS y SANT.
- d. La contingencia que mas problemas provoca son las que tiene asociada el disparo de la línea SMAR-STOM.
- e. El escenario que presenta los peores perfiles de voltaje corresponde a la importación de 40 MW desde Guatemala.
- f. Se comprueba que una vez determinado cuál escenario de transferencia provoca los peores resultados para contingencias N-1, el escenario de transferencia que provoca los peores resultados para contingencias N-2 es el mismo.

4. SELECCIÓN DE CONTINGENCIAS CRÍTICAS

Del análisis precedente se vió que el peor escenario corresponde a la importación de Guatemala hacia El Salvador de 40 MW, el cual será el caso base en el presente análisis. Se efectuará el análisis modelando la carga como el 50% de potencia activa a corriente constante y el 50% de potencia reactiva a impedancia constante, lo cual supone que una parte de la carga es dependiente del voltaje y su efecto sobre el margen de potencia reactiva antes de llegar al punto de colapso de voltaje. Este modelo es mejor que considerar toda la carga a potencia constante, sin embargo, tampoco es tan optimista que si se modelara toda la carga a impedancia constante.

La metodología para el presente análisis, consiste en analizar las curvas V-Q de los nodos más afectados por abatimiento del voltaje cuando ocurre una contingencia N-1 y N-2.

4.1. Reserva de reactivos para contingencias N-1

De los análisis precedentes, los nodos que aparecieron con problemas de violación del límite inferior de la banda de voltaje de operación de emergencia son los siguientes:

Nodo 115 kV	Causa
San Miguel	Disparo de línea BERL-SMIG
Tecoluca y Ozatlán	Disparo de línea SRAF-TECO
Nuevo Cuscatlán, Santo Tomás y Pedregal	Disparo de línea SMAR-STOM Disparo de línea NCUS-ATEO
San Antonio Abad	Disparo de línea SANT-NEJA

A continuación se muestran las curvas V-Q para el caso base en condiciones normales de operación de estos nodos y en condiciones N-1.

4.1.1. Nodo 115 kV de San Miguel

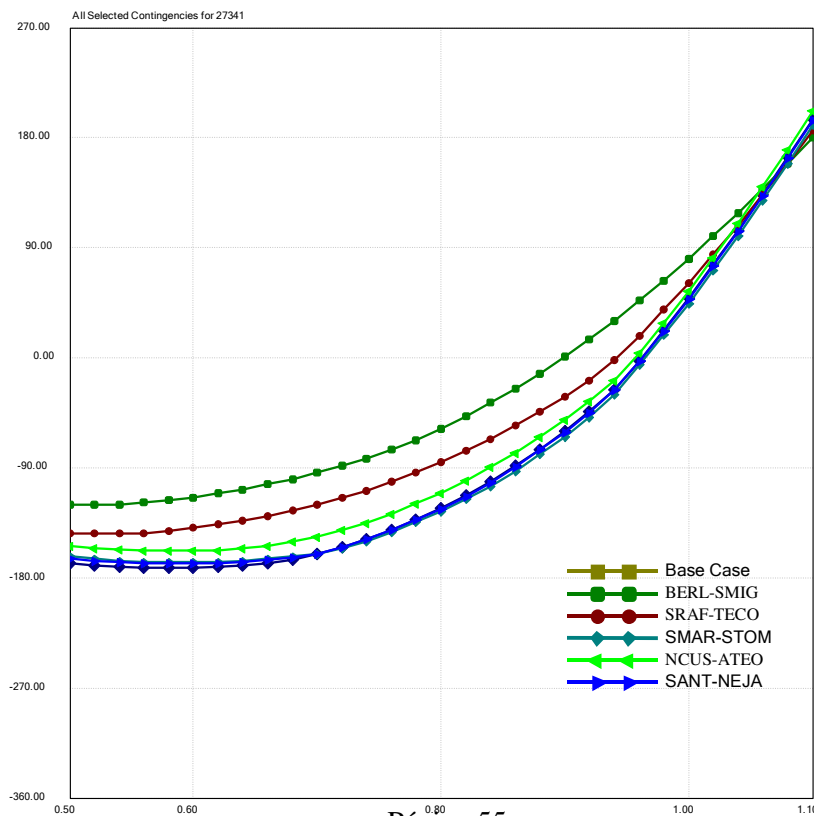

4.1.2. Nodo 115 kV de Tecoluca

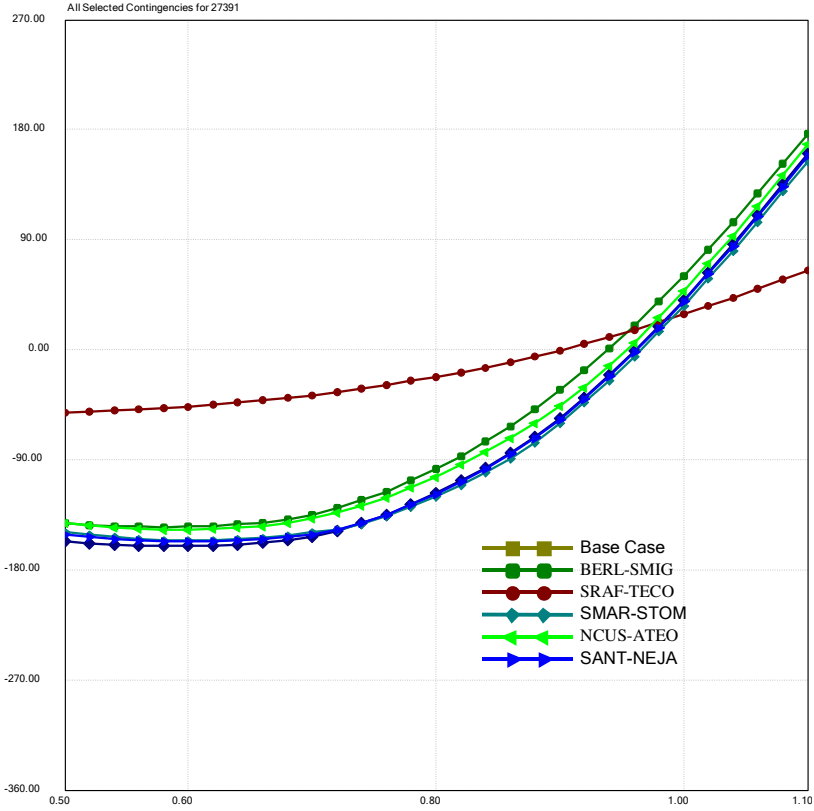

4.1.3. Nodo 115 kV de Ozatlán

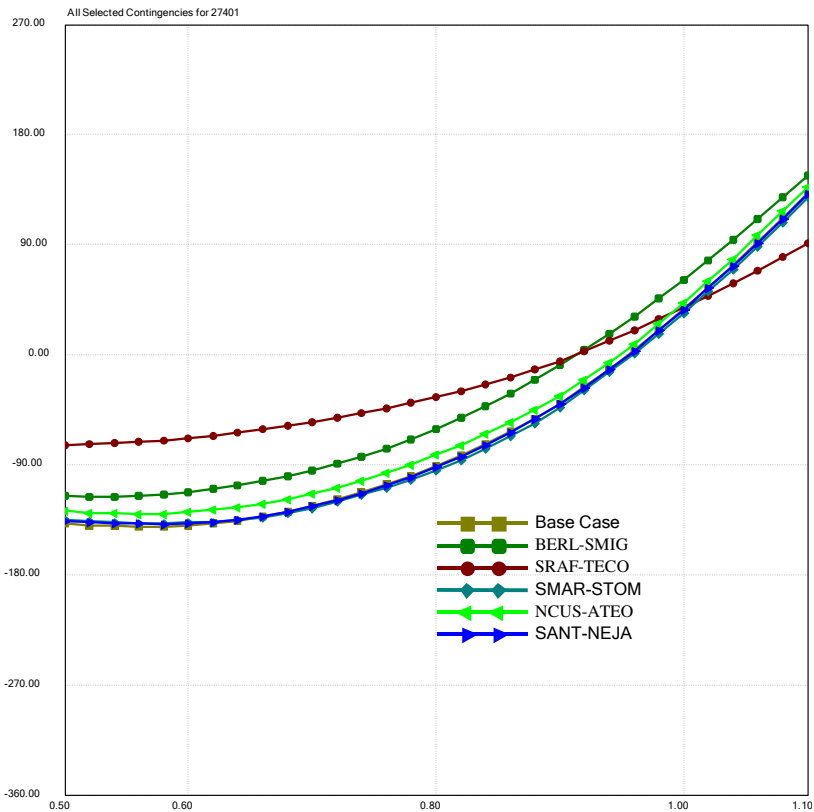

4.1.4. Nodos 115 kV de Santo Tomás

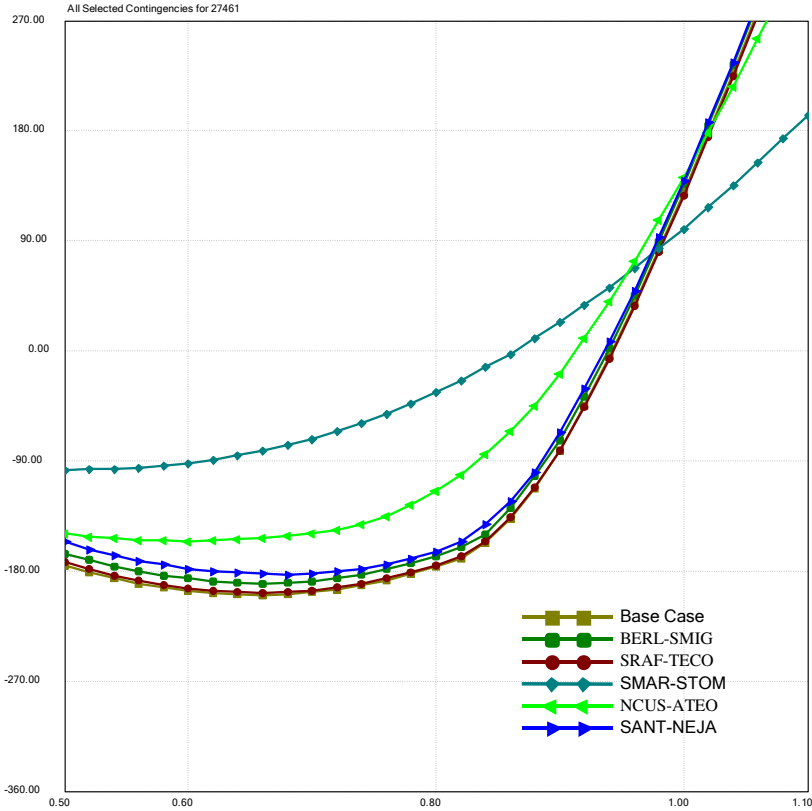

4.1.5. Nodos 115 kV de El Pedregal

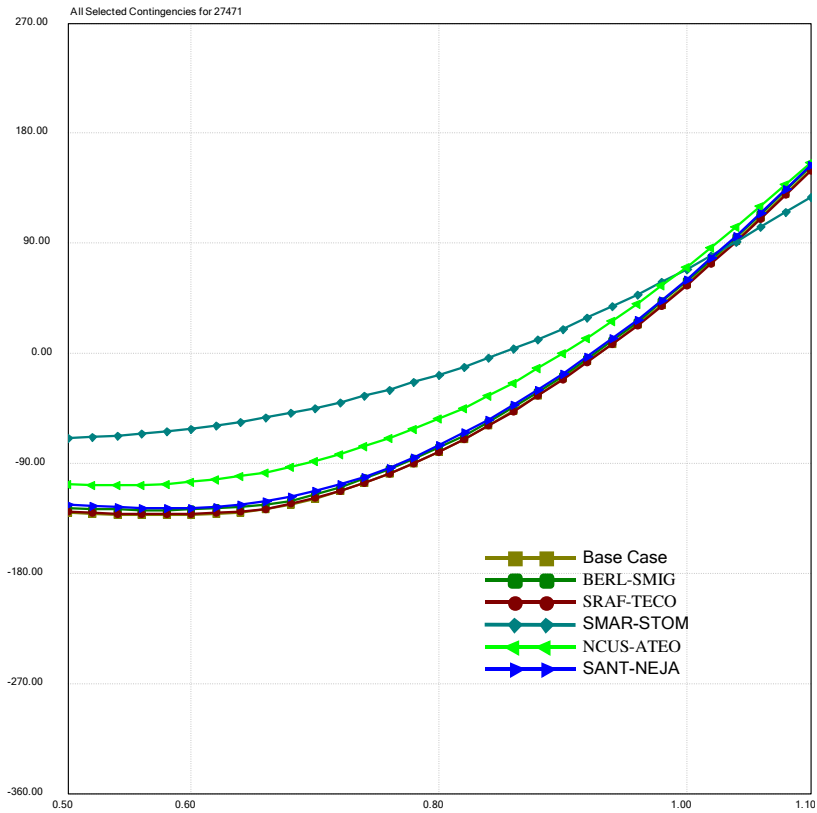

4.1.6. Nodo 115 kV de San Antonio Abad

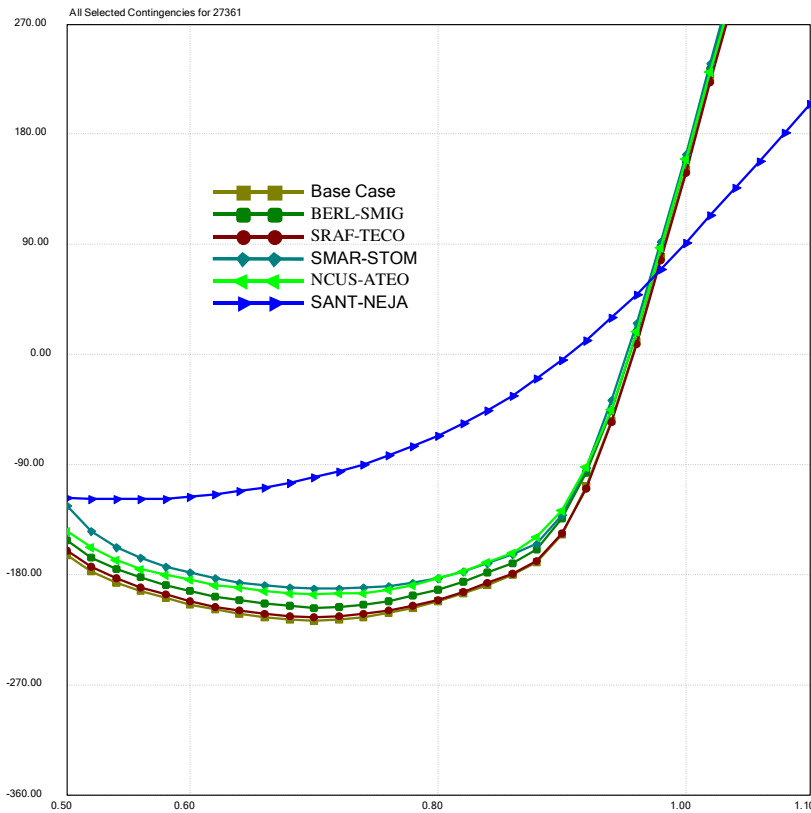

La siguiente tabla muestra los nodos más débiles y la reserva de potencia reactiva por contingencia y por bus analizado:

CASO: MX_GE56.CNV	BUSES					
	TECO-115	OZAT-115	SMIG-115	SANT-115	STOM-115	PEDR-115
BASE	161	141	172	217	200	132
BERL-SMIG	145	116	120	207	190	128
SRAF-TECO	51	74	144	215	198	132
SMAR-STOM	156	138	167	192	97	69
NCUS-ATEO	147	130	158	196	155	108
SANT-NEJA	157	139	168	118	183	127

4.2. Reserva de reactivos para contingencias N-2

Continuando el mismo análisis para las contingencias N-2:

CASO: GUAT => ELSA 56 MW	BUSES						TOTAL
	TECO-115	OZAT-115	SMIG-115	SANT-115	STOM-115	PEDR-115	
BERL-SMIG & 15SE-SMIG	97	40	13	166	154	109	579
SMAR-STOM & CGRA-U1	137	122	149	166	84	62	720
SMAR-STOM & ACAJ-U5	137	123	145	159	82	61	707
SMAR-STOM & ATEO-GM	138	125	150	160	82	61	716
SMAR-STOM & 15SE-U1	136	120	145	167	84	62	714
BERL-SMIG & 15SE-U1	124	100	104	174	162	111	775
BERL-SMIG & CGRA-U1	126	102	106	175	162	111	782
SANT-NEJA & ACAJ-ATEO	144	129	155	97	155	112	792
SMAR-STOM & ACAJ-ATEO	143	129	155	167	84	61	739
SMAR-STOM & SRAF-SMAR	149	135	165	184	95	68	796
SMAR-STOM & NEJA-OPIC	148	133	160	181	97	68	787
SMAR-STOM & AHUA-SANA	143	128	155	169	91	67	753
NCUS-ATEO & SANT-ATEO	117	106	129	141	122	84	699
SMAR-STOM & AHUA-SONS	140	127	153	150	80	61	711
SMAR-STOM & SANT-NEJA	123	115	135	18	7	3	401
SMAR-STOM & CGRA-NEJA	152	135	164	183	94	68	796
SMAR-STOM & ACAJ-SONS	155	137	166	188	96	69	811
SMAR-STOM & SONS-ATEO	143	129	155	164	81	59	731
SMAR-STOM & 15SE-SMAR	152	136	164	178	93	68	791
SRAF-TECO & 15SE-SMIG	34	46	77	208	191	129	685
SMAR-STOM & SANT-ATEO	155	137	167	188	56	42	745
SRAF-TECO & BERL-SMIG	27	37	67	199	183	126	639
TECO-OZAT & BERL-SMIG	137	53	86	211	194	130	811

Del cuadro precedente, se presenta el mismo listado de contingencias ordenados por el total; esto dará una indicación de cuáles son las peores contingencias.

No.	CONTINGENCIA	TOTAL MVARs	No.	CONTINGENCIA	TOTAL MVARs
1	SMAR-STOM & SANT-NEJA	401	12	SMAR-STOM & ACAJ-ATEO	739
2	BERL-SMIG & 15SE-SMIG	579	13	SMAR-STOM & SANT-ATEO	745
3	SRAF-TECO & BERL-SMIG	639	14	SMAR-STOM & AHUA-SANA	753
4	SRAF-TECO & 15SE-SMIG	685	15	BERL-SMIG & 15SE-U1	775
5	NCUS-ATEO & SANT-ATEO	699	16	BERL-SMIG & CGRA-U1	782
6	SMAR-STOM & ACAJ-U5	707	17	SMAR-STOM & NEJA-OPIC	787
7	SMAR-STOM & AHUA-SONS	711	18	SMAR-STOM & 15SE-SMAR	791
8	SMAR-STOM & 15SE-U1	714	19	SANT-NEJA & ACAJ-ATEO	792
9	SMAR-STOM & ATEO-GM	716	20	SMAR-STOM & SRAF-SMAR	796
10	SMAR-STOM & CGRA-U1	720	21	SMAR-STOM & CGRA-NEJA	796
11	SMAR-STOM & SONS-ATEO	731	22	SMAR-STOM & ACAJ-SONS	811
			23	TECO-OZAT & BERL-SMIG	811

Análisis:

- Los nodos más débiles son Tecoluca y Ozatlán, seguido muy de cerca por San Miguel y El Pedregal; y el nodo crítico en este escenario de demanda es Tecoluca ante disparo de SRAF-TECO.
- La contingencia que presenta menos reserva de reactivos para el control del voltaje corresponde al disparo de la línea San Rafael Cedros- Tecoluca, dejando a Tecoluca con un margen de reserva de 51 Mvars, seguido por Ozatlán con un margen de 74 Mvars aproximadamente.

- La peor contingencia que puede ocurrir después de ocurrir la peor contingencia listadas en la Tabla son las siguientes:

CASO	PEORES CONTINGENCIAS N-1	SIGUIENTE PEOR CONTINGENCIA N-2 CON COLAPSO.	ID	SIGUIENTE PEOR CONTINGENCIA N-2 SIN C.V.	ID
1	SMAR-STOM	SANT-NEJA	1	ACAJ-U5	16
2	BERL-SMIG	15SE-SMIG	2	15SE-U1	16
3	SRAF-TECO	BERL-SMIG	3	15SE-SMIG	4
4	NCUS-ATEO			SANT-ATEO	5
5	SANT-NEJA	SMAR-STOM	1	ACAJ-ATEO	19

4.3. Cálculo del margen de reserva reactiva

A continuación se muestran las gráficas QV del caso base (MM_GE56.cnv) con la carga aumentada al 105% para las siguientes contingencias críticas:

- Contingencia 1: BERL-SMIG
- Contingencia 2: SRAF-TECO
- Contingencia 3: SMAR-STOM
- Contingencia 4: NCUS-ATEO
- Contingencia 5: SANT-NEJA

Las gráficas QV corresponde a los nodos críticos.

Nodo San Miguel 115 kV:

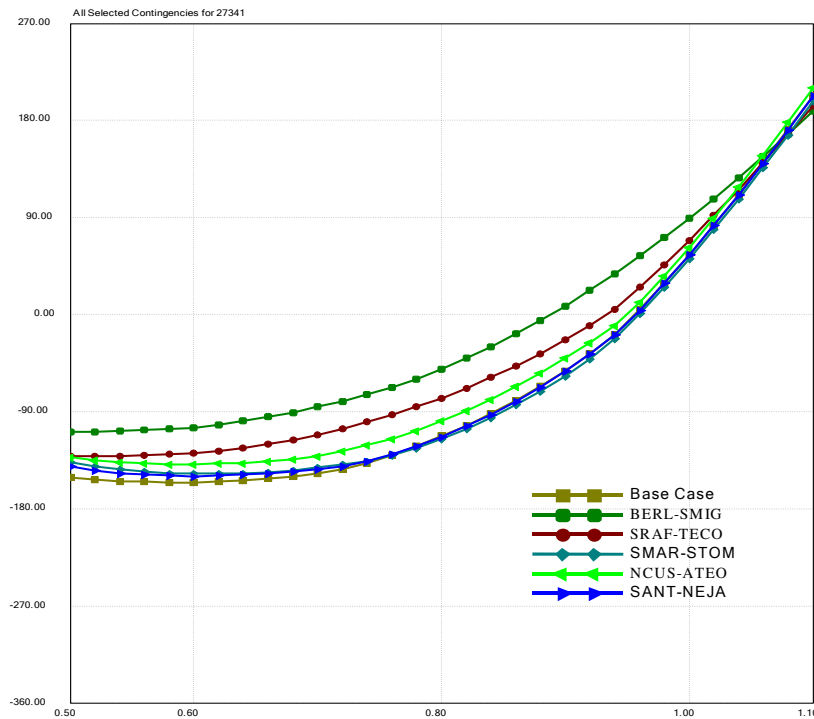

Nodo Ozatlan 115 kV:

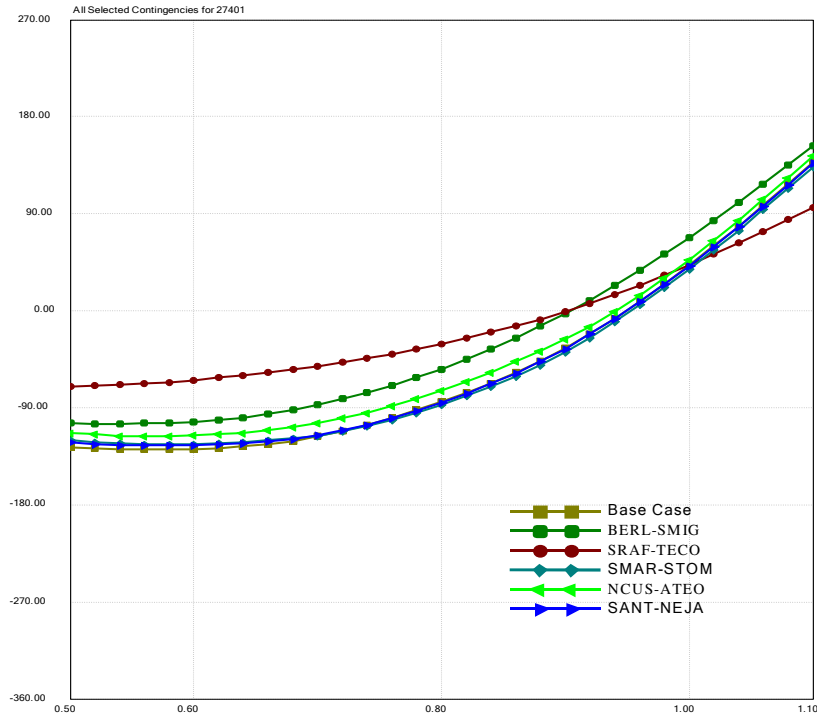

Nodo Tecoluca 115 kV:

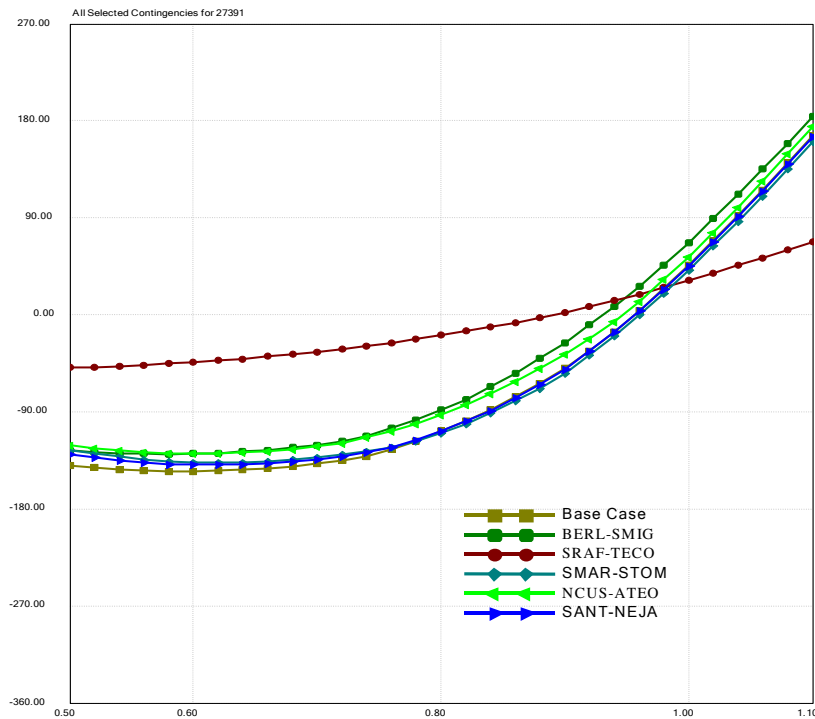

Nodo Santo Tomás 115 kV:

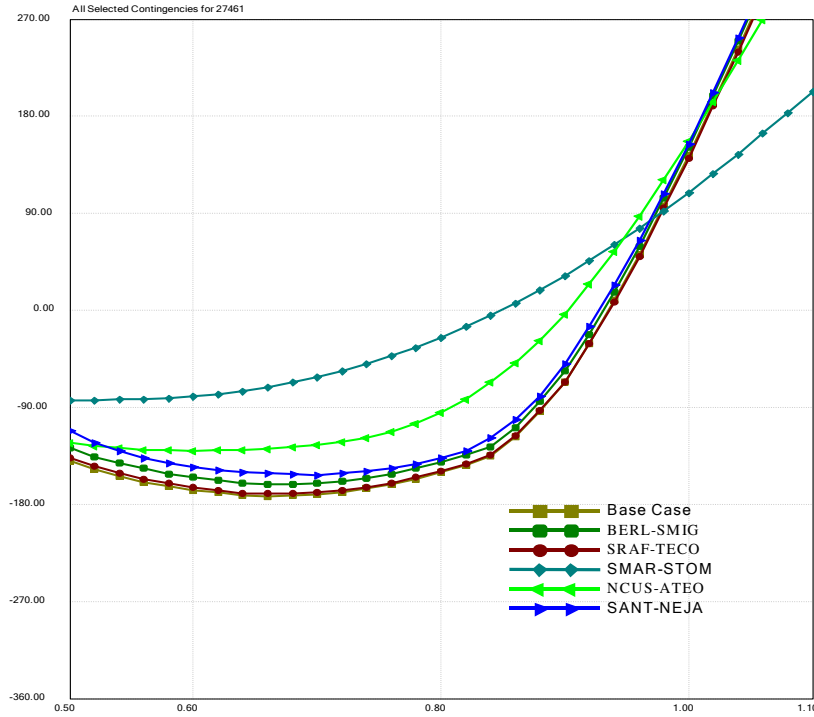

Nodo El Pedregal 115 kV:

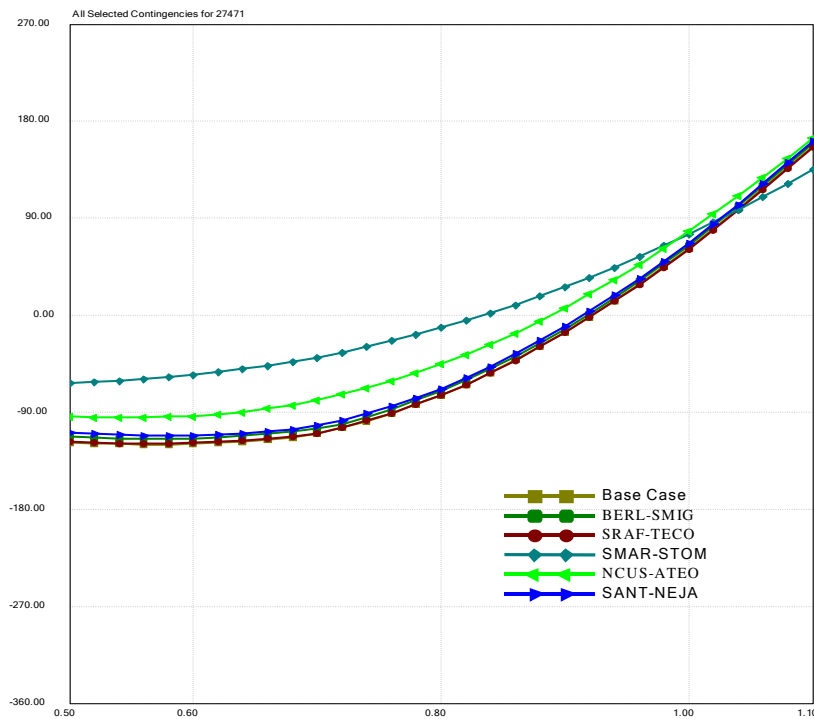

Nodo San Antonio Abad 115 kV:

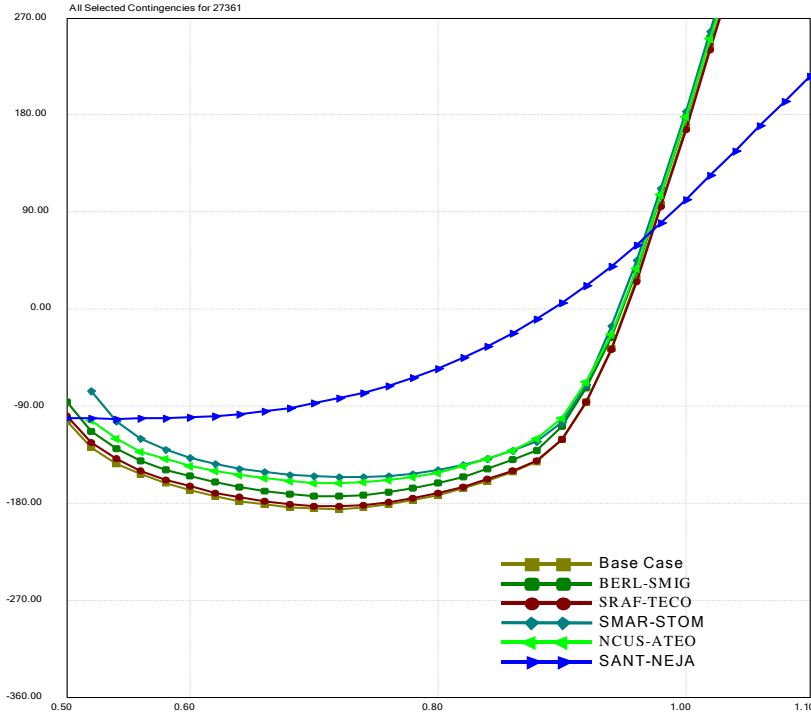

La siguiente tabla muestra los nodos más débiles y el margen de potencia reactiva por contingencia y por bus analizado:

CASO MXA_GE56.CNV	BUSES					
	TECO-115	OZAT-115	SANT-115	SMIG-115	STOM-115	PEDR-115
BERL-SMIG	129	105	174	109	162	115
SRAF-TECO	49	71	183	131	170	119
SMAR-STOM	137	124	156	148	84	63
NCUS-ATEO	129	116	162	139	130	95
SANT-NEJA	139	125	102	150	153	112

CASO	BUS VOLTAJE	MARGEN DE POTENCIA REACTIVA (MVAR)			MARGEN REQUERIDO (MVAR)	CUMPLIMIENTO DE CRITERIO?
		N-0 CASO BASE	N-1 CARGA 100%	N-1 CARGA +5%		
BERL-SMIG	SMIG-115 KV	172	120	109	11	Si
	OZAT-115 KV	141	116	105	11	Si
SRAF-TECO	TECO-115 KV	161	51	49	2	Si
	OZAT-115KV	141	74	71	3	Si
SMAR-STOM	STOM-115 KV	200	97	84	13	Si
	PEDR-115 KV	132	69	63	6	Si
NUCS-ATEO	PEDR-115 KV	132	108	95	13	Si
SANT-NEJA	SANT-115 KV	217	118	102	16	Si

4.4. Determinación de las curvas P-V de las contingencias críticas

Para el presente análisis, se ha modelado la carga convirtiéndolo el total de potencia activa en 50% a corriente constante y convirtiéndolo el total de potencia reactiva en 50% a impedancia constante.

Para obtener las curvas PV, inicialmente se realizó una disminución de la generación y carga con el método explicado arriba, en un 20% (*MM_GE56d.SAV*) como punto de partida o de origen de dicha curva:

X-- AREA --X	FROM GENERATION	TO LOAD	TO BUS SHUNT	TO LINE SHUNT	FROM CHARGING	TO NET INT	LOSSES	DESIRED NET INT
2	660.8	655.4	0.0	0.0	0.0	-12.8	11.1	0.0
SALVADOR	199.7	212.9	-73.1	0.0	88.5	8.2	124.2	
TOTALS	660.8	655.4	0.0	0.0	0.0	-12.8	11.1	0.0
	199.7	212.9	-73.1	0.0	88.5	8.2	124.2	

Los casos a analizar son tomados de la Tabla xx, que se repite a continuación:

CASO ⁶	PEORES CONTINGENCIAS N-1	SIGUIENTE PEOR CONTINGENCIA N-2 CON COLAPSO.	ID	SIGUIENTE PEOR CONTINGENCIA N-2 SIN C.V.	ID
5	SMAR-STOM	SANT-NEJA	1	ACAJ-U5	16
6	BERL-SMIG	15SE-SMIG	2	15SE-U1	16
7	SRAF-TECO	BERL-SMIG	3	15SE-SMIG	4
8	NCUS-ATEO			SANT-ATEO	5
9	SANT-NEJA	SMAR-STOM	1	ACAJ-ATEO	19

Por comparación, además de los casos de la tabla anterior, se ha complementado con los casos no repetidos del escenario de demanda máxima:

CASO	PEORES CONTINGENCIAS N-1	ID	SIGUIENTE PEOR CONTINGENCIA N-2 SIN C.V.	
1	BERL-SMIG	1	SMIG-OZAT	16
2	SMAR-STOM	4	ACAJ-ATEO	15
3	SRAF-TECO	2	15SE-U1	5
4	SRAF-TECO	3	NCUS-ATEO	6

⁶ Se ha usado la misma numeración del Anexo 1 para mantener la correspondencias por fines de comparación.

4.4.1. Caso 1: BERL-SMIG & SMIG-OZAT

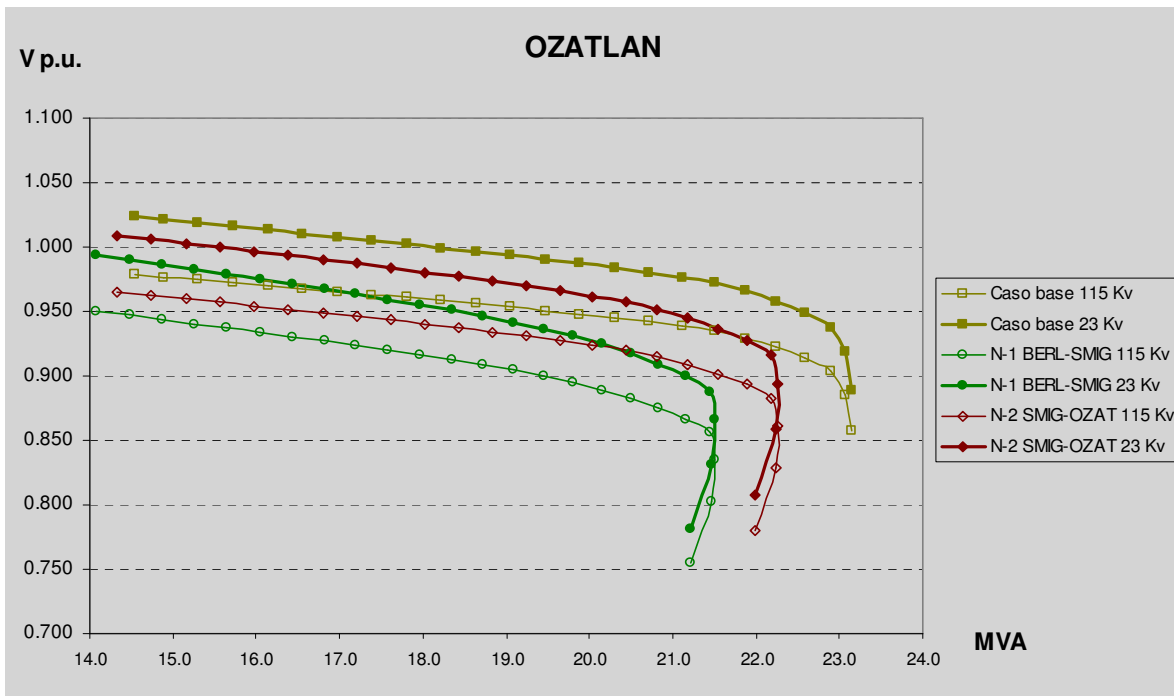
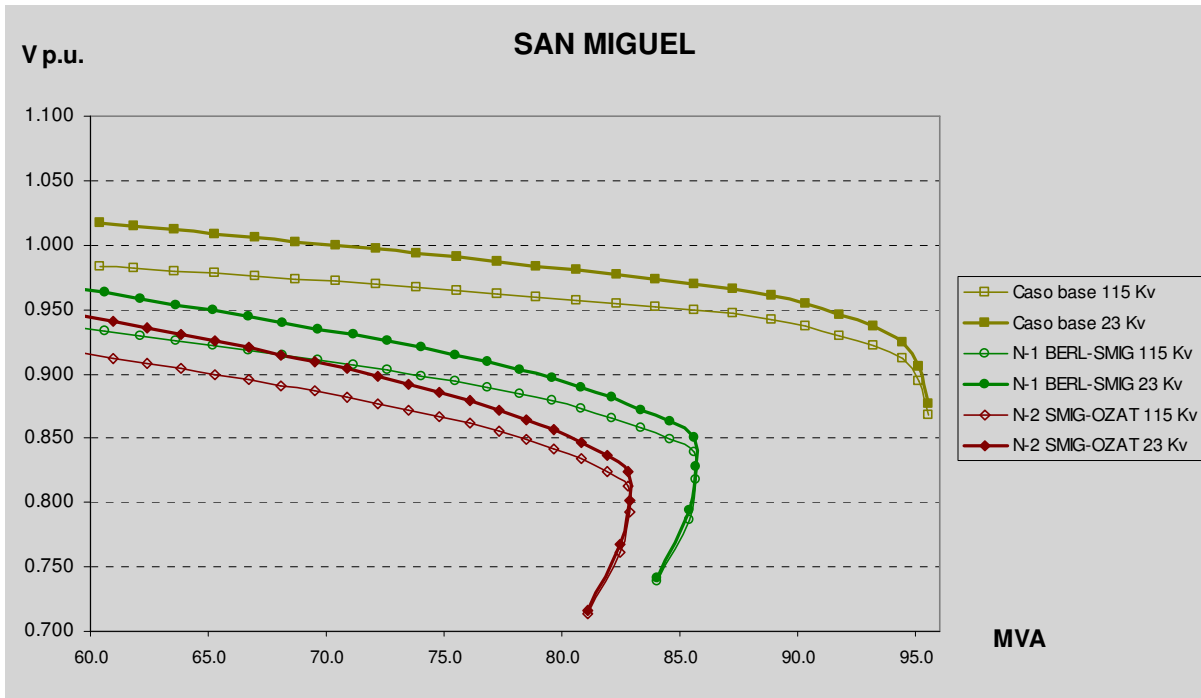

4.4.2. Caso 2: SMAR-STOM & ACAJ-ATEO

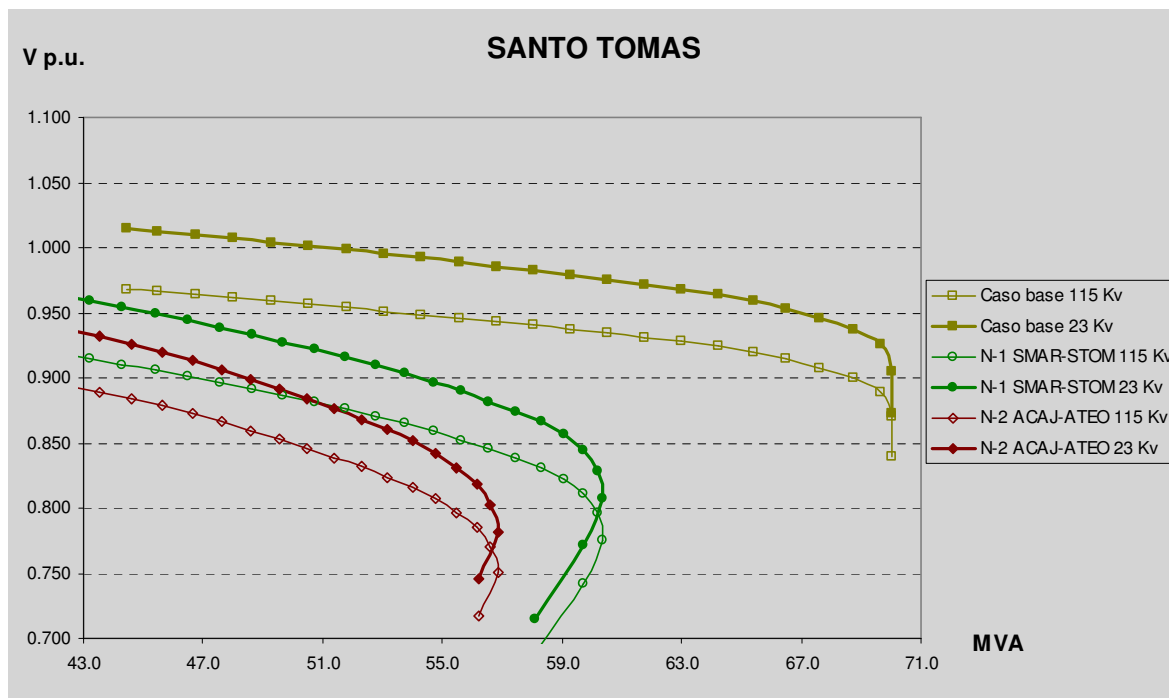
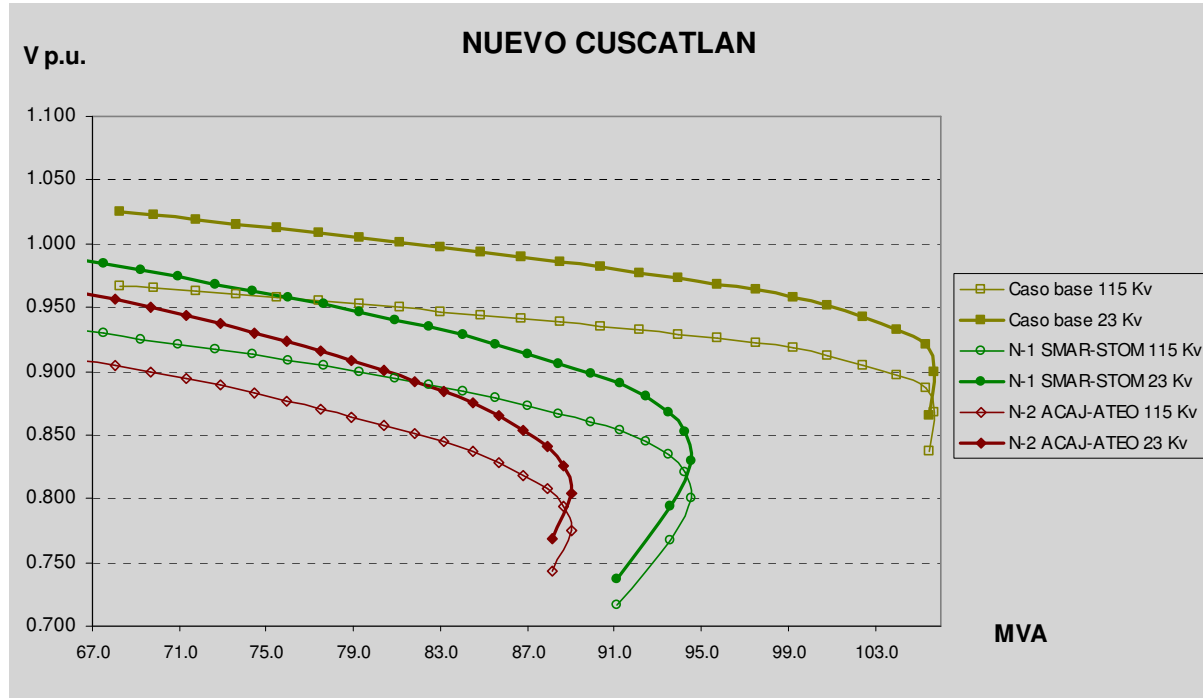

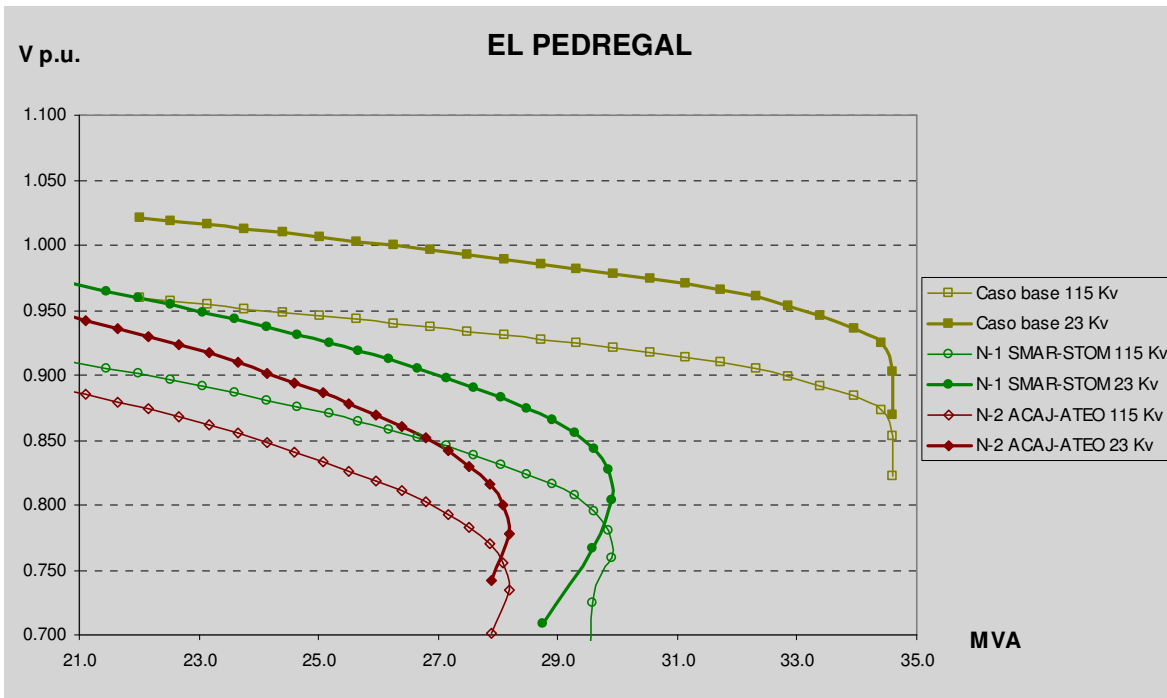

4.4.3. Caso3.: SRAF-TECO & 15SE-U1

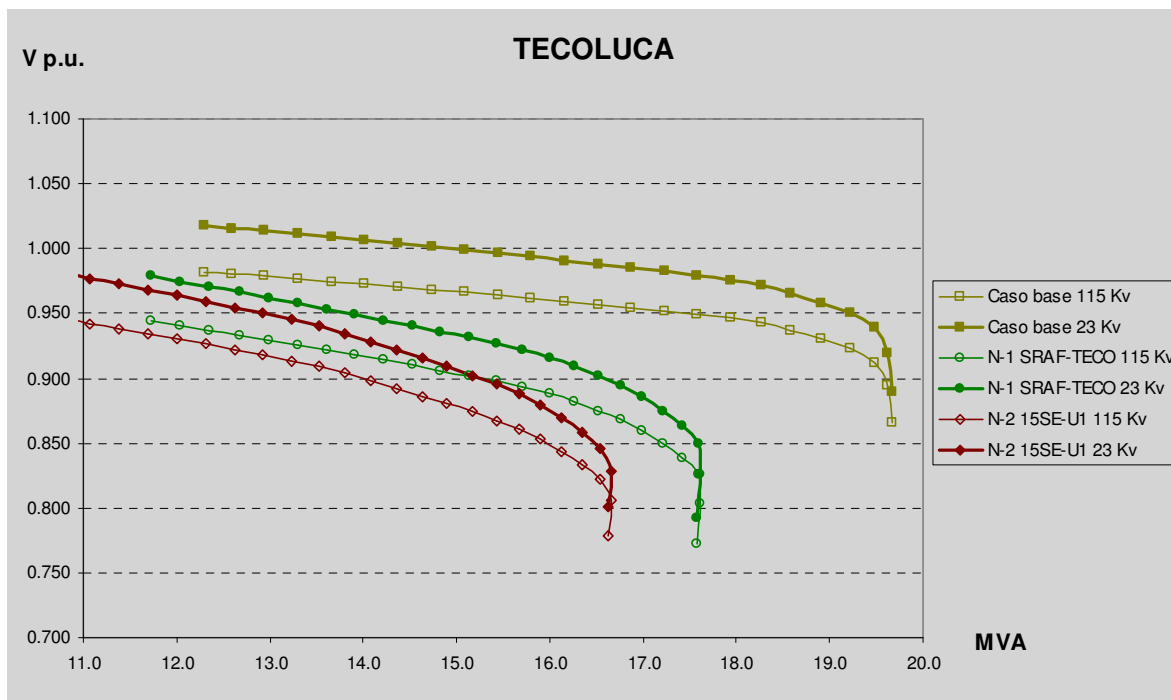

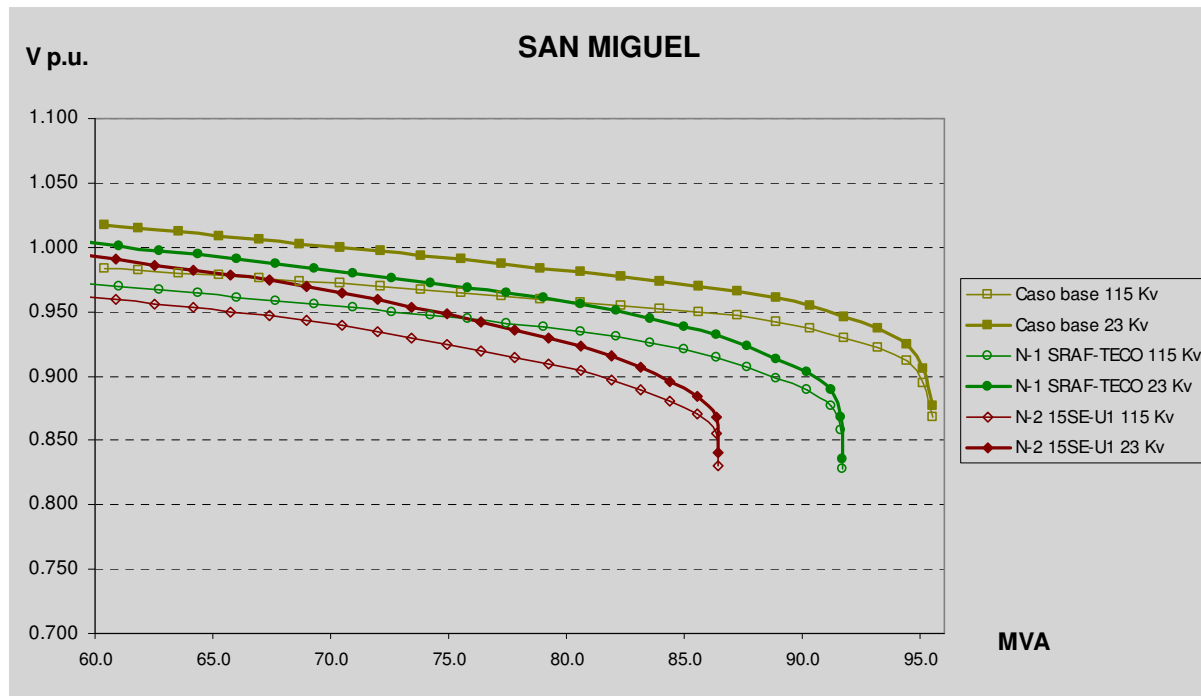
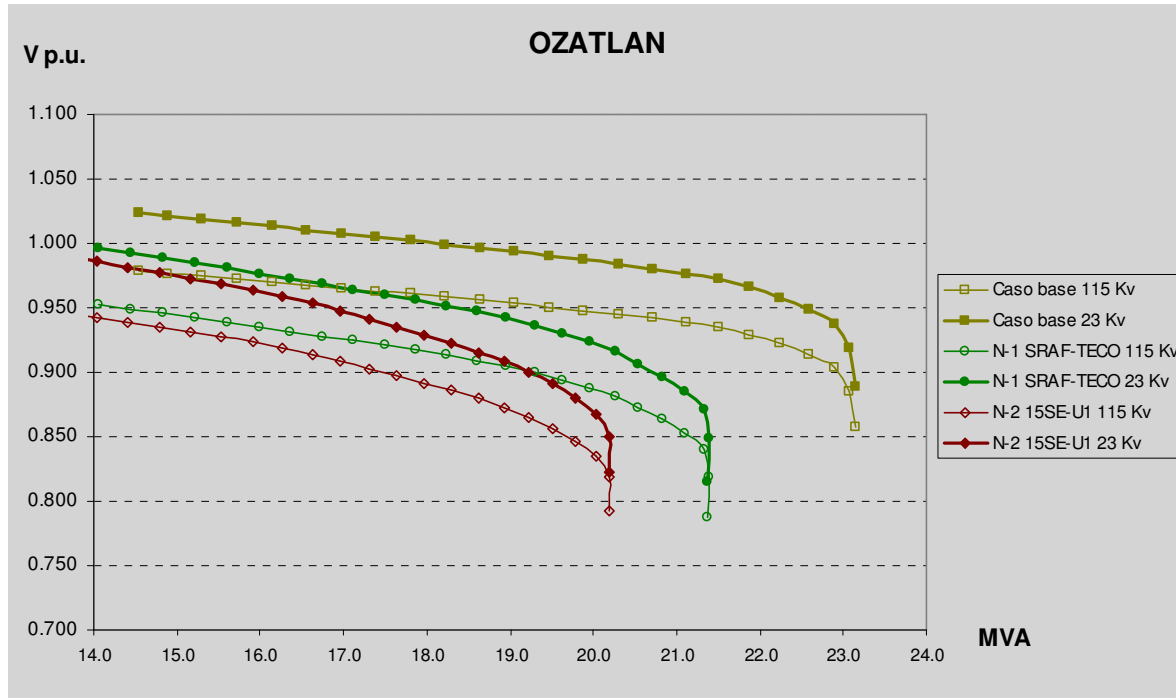

4.4.4. Caso 4: SRAF-TECO & NCUS-ATEO

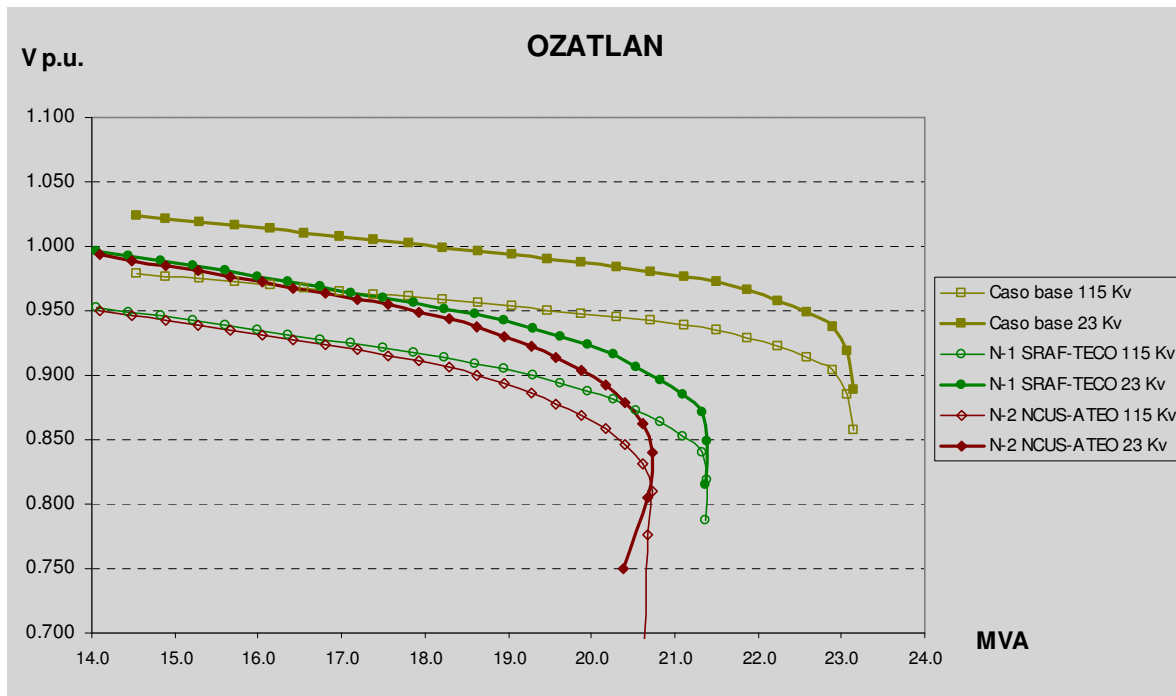
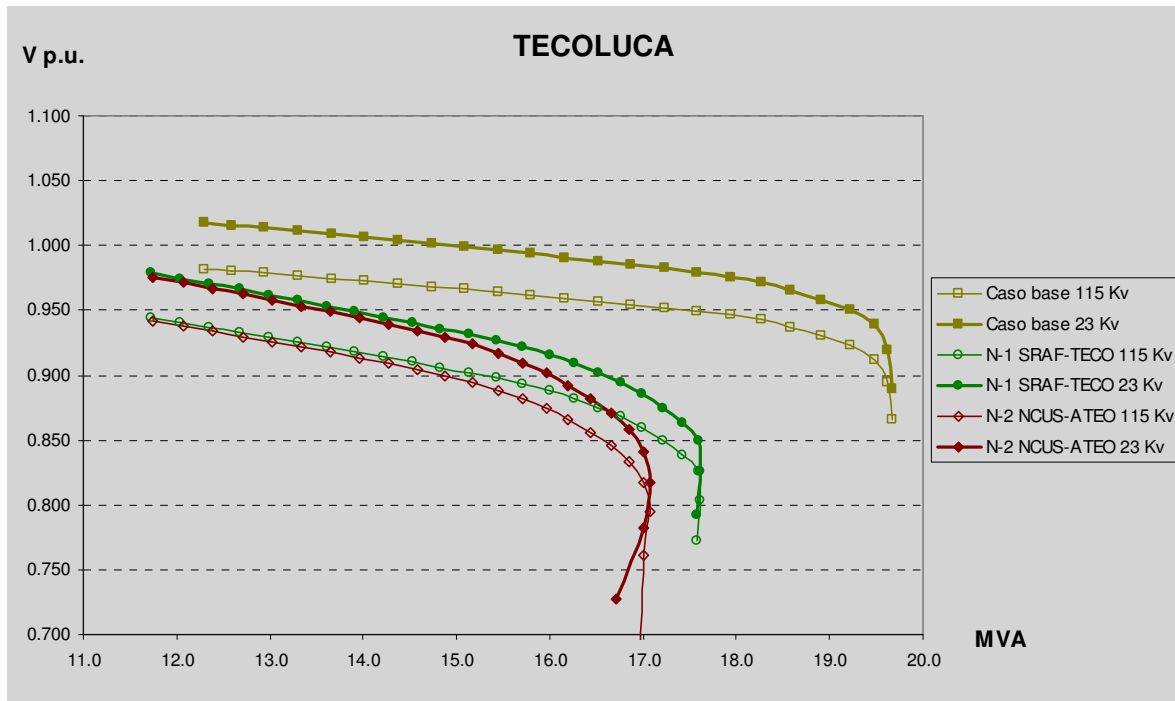

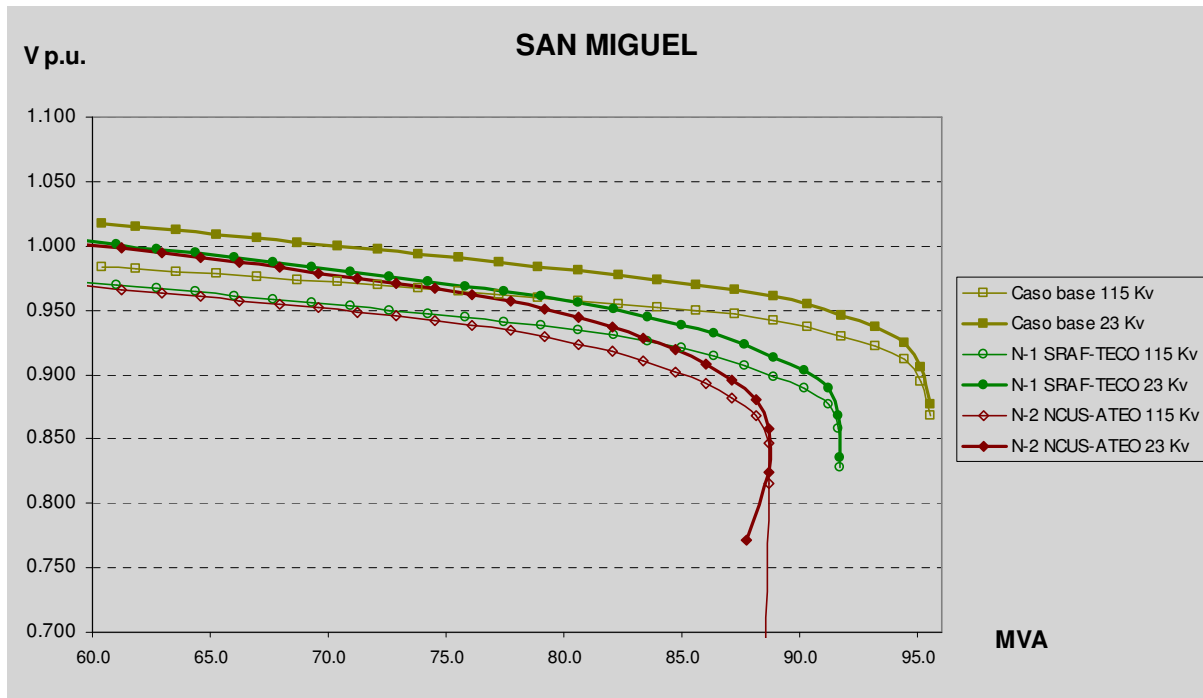

4.4.5. Casos 5: SMAR-STOM & ACAJ-U5

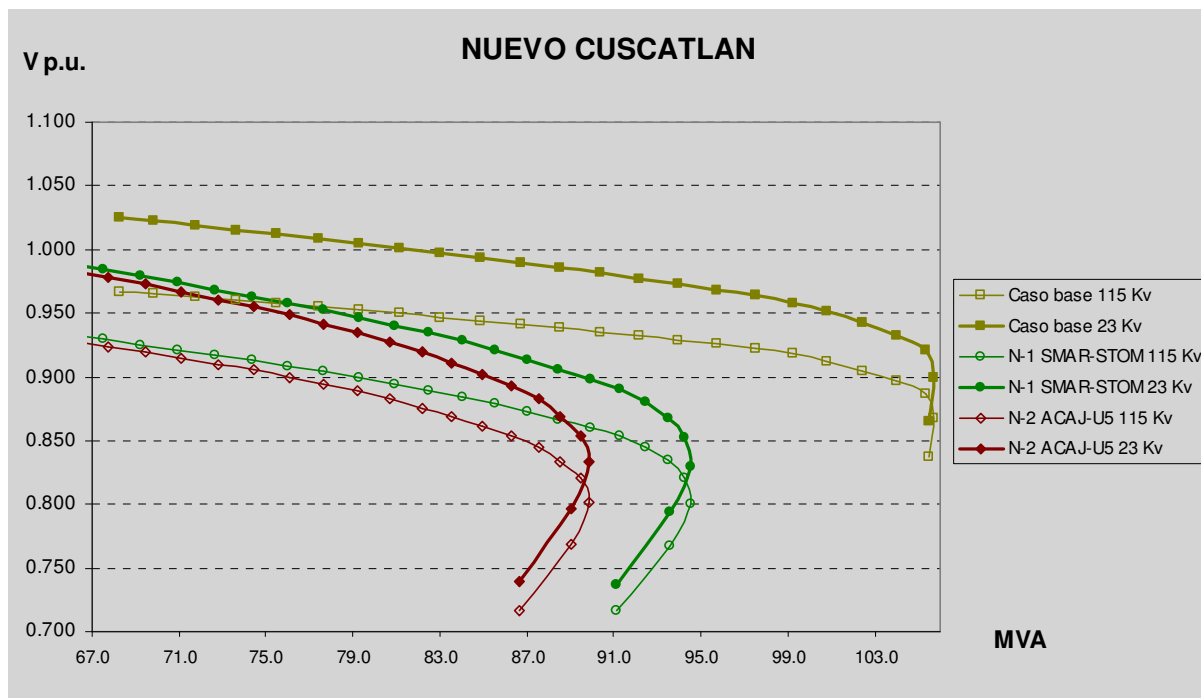

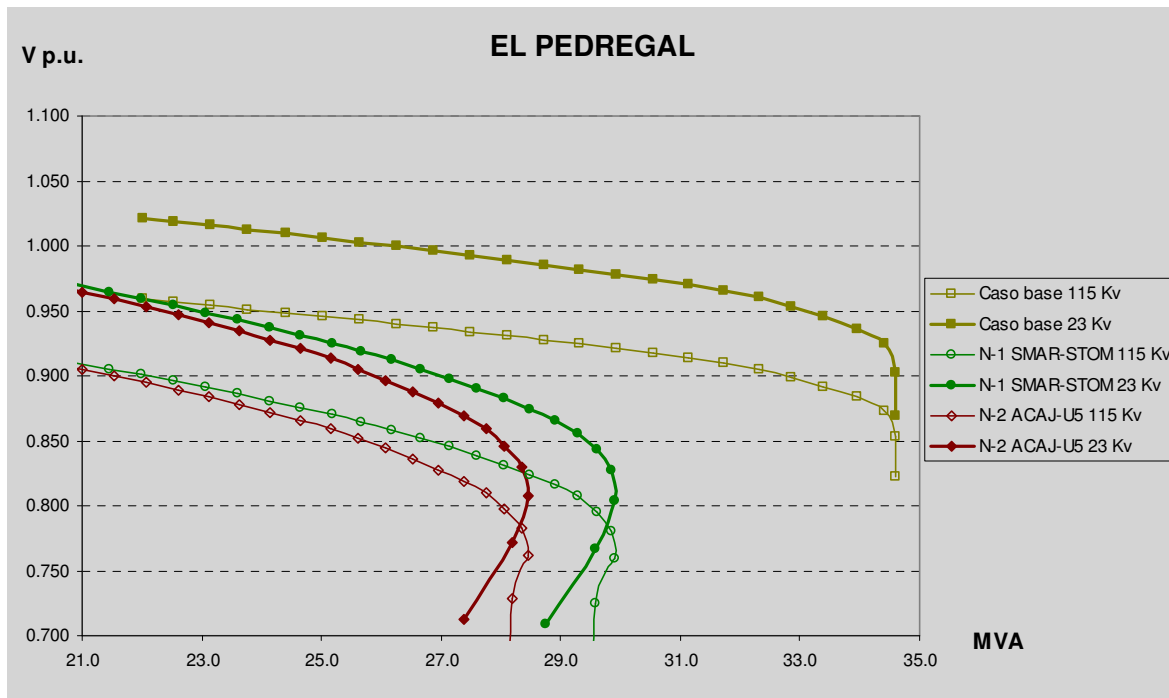
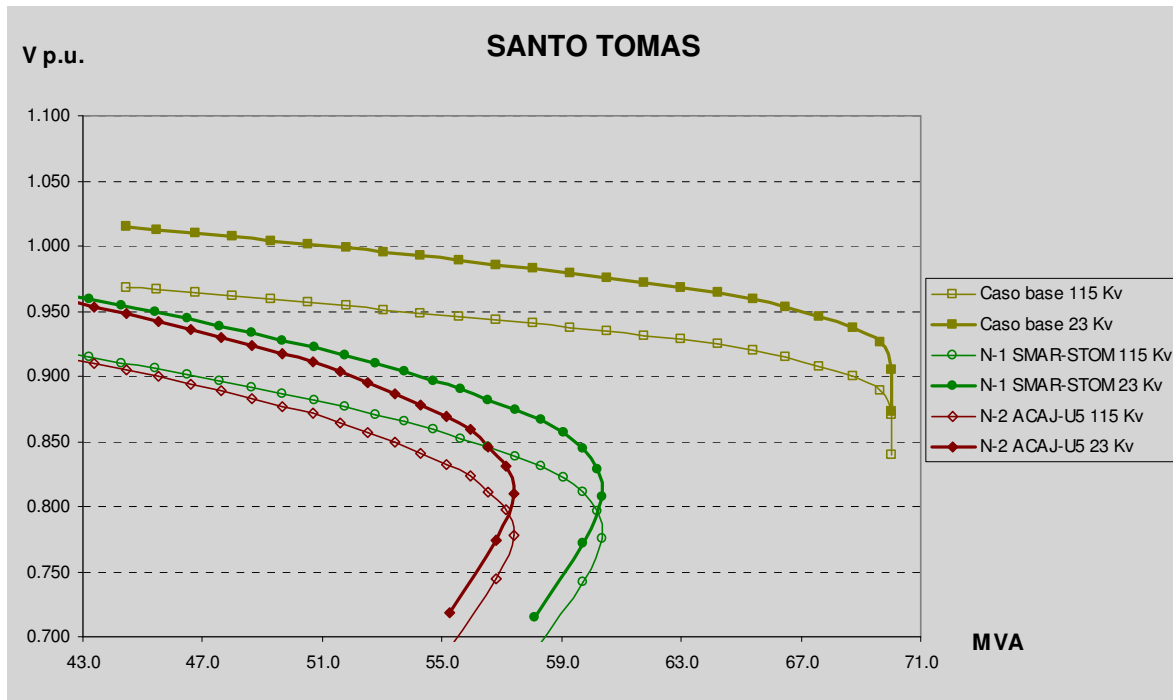

4.4.6. Caso 6: BERL-SMIG & 15SE-U1

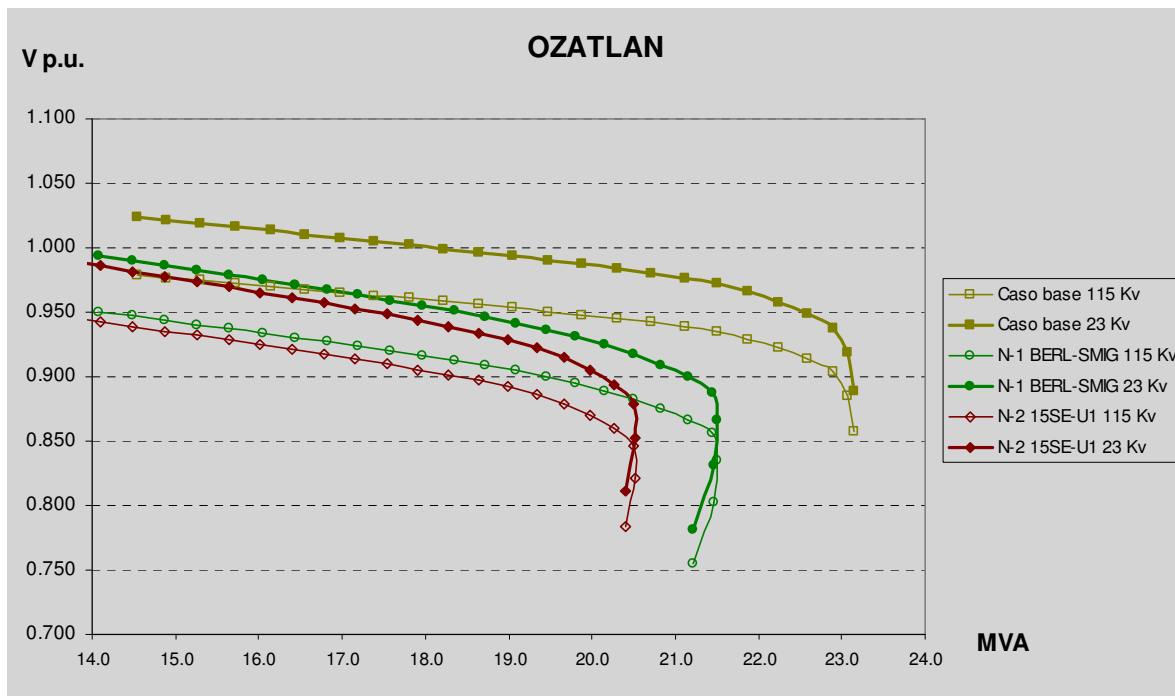
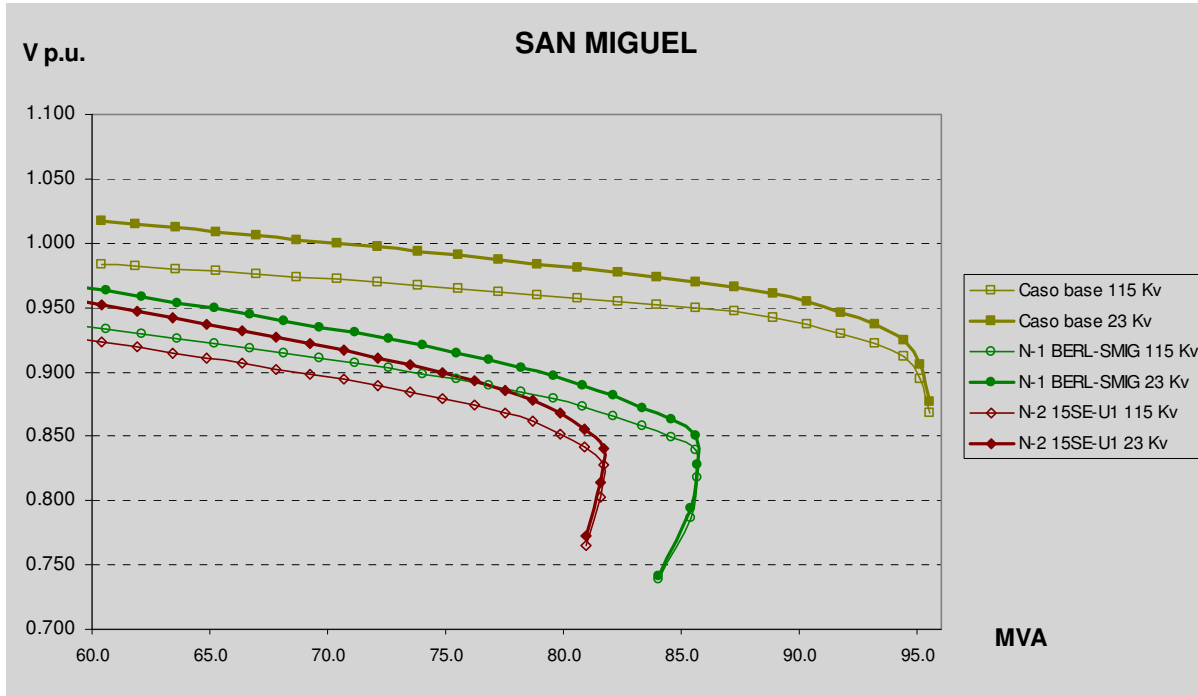

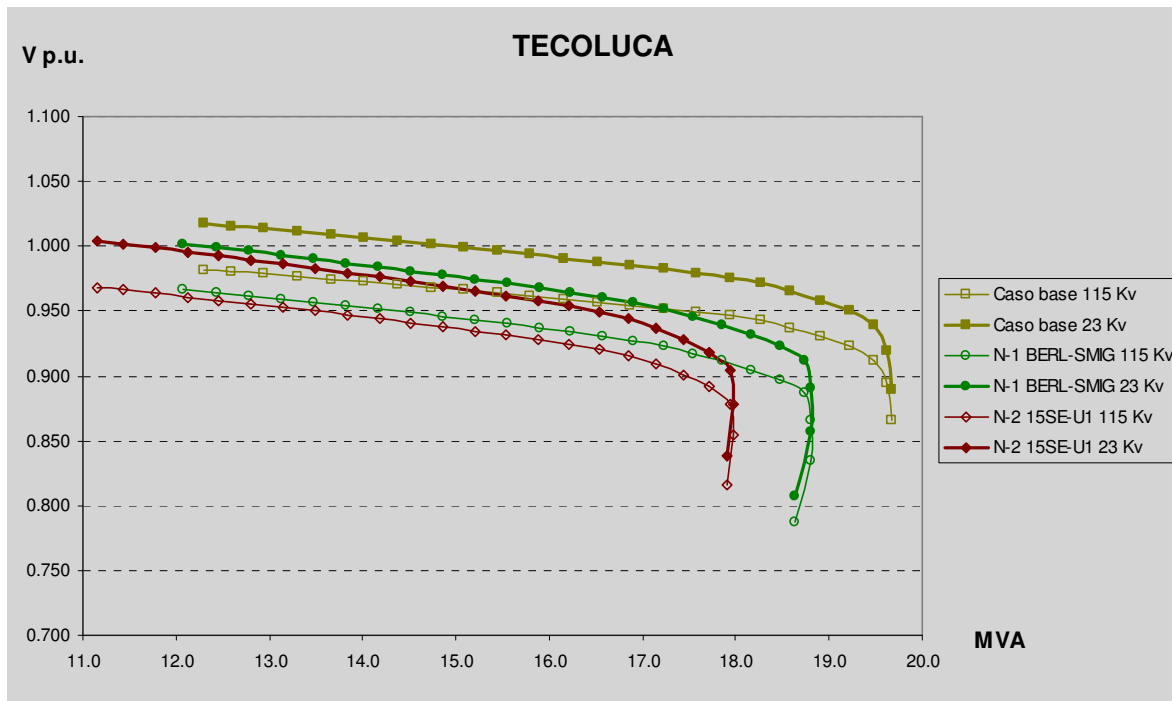

4.4.7. Caso 7: SRAF-TECO & 15SE-SMIG

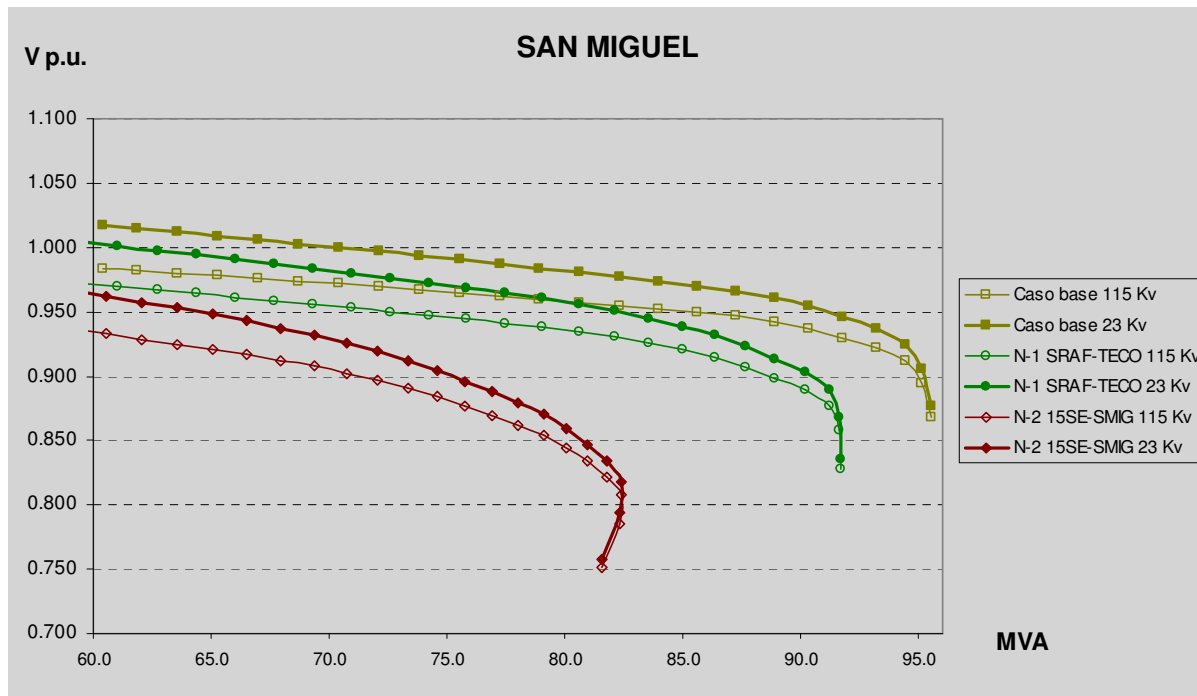

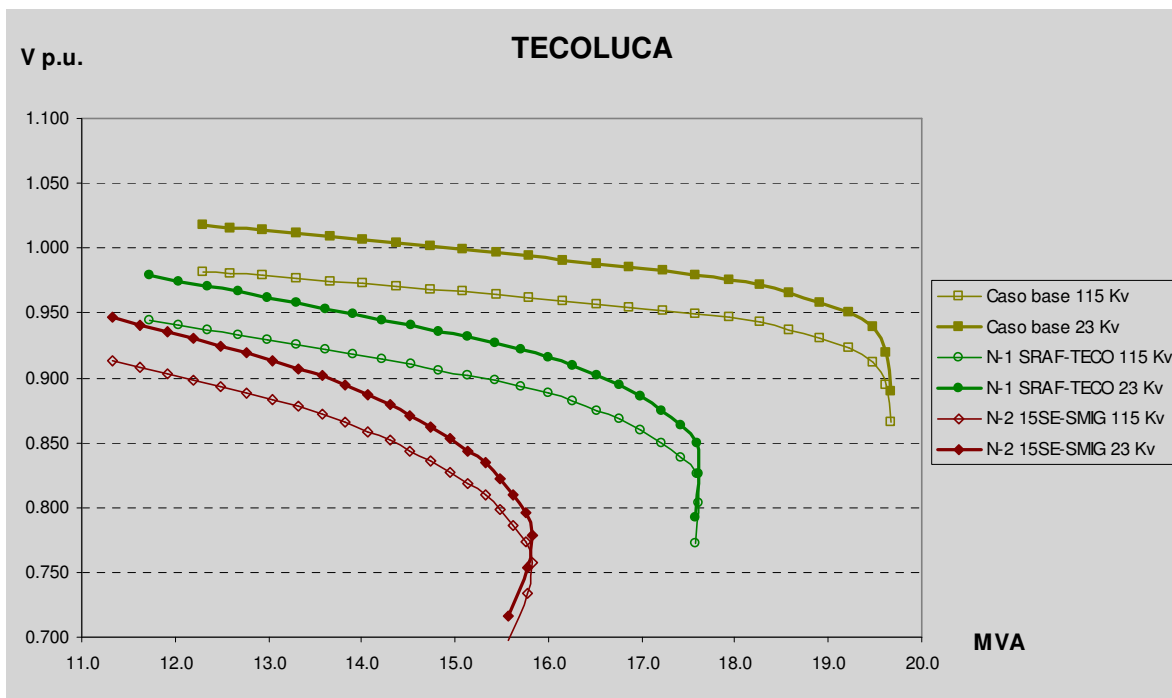
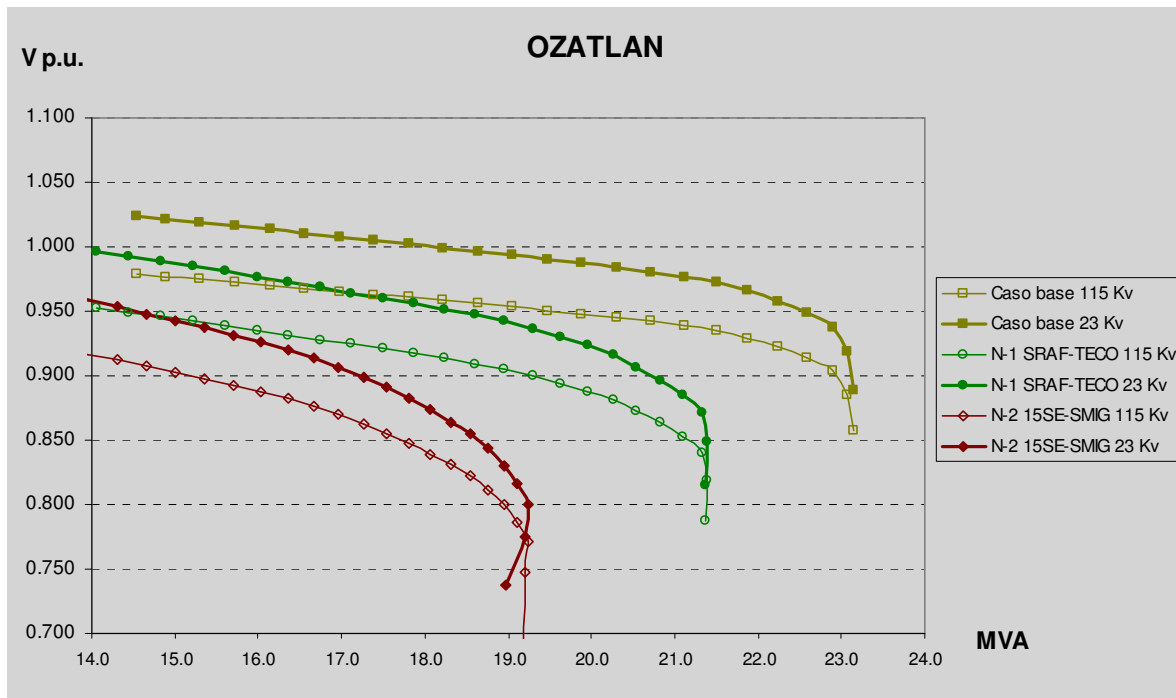

4.4.8. Caso 8: NCUS-ATEO & SANT-ATEO

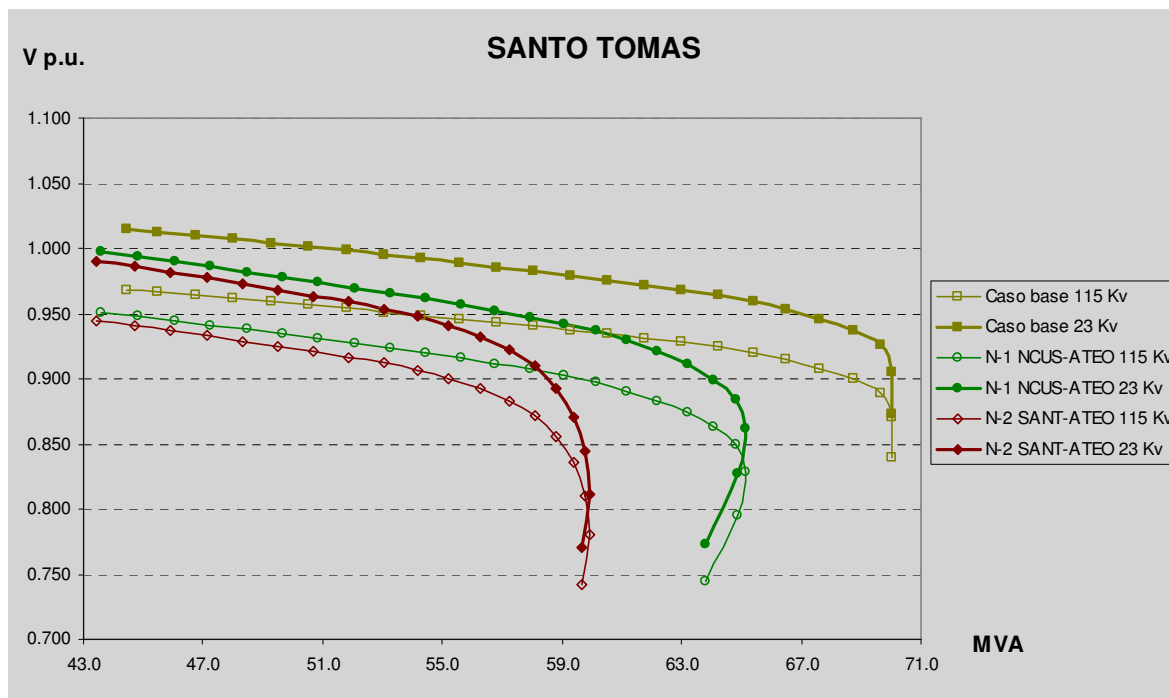
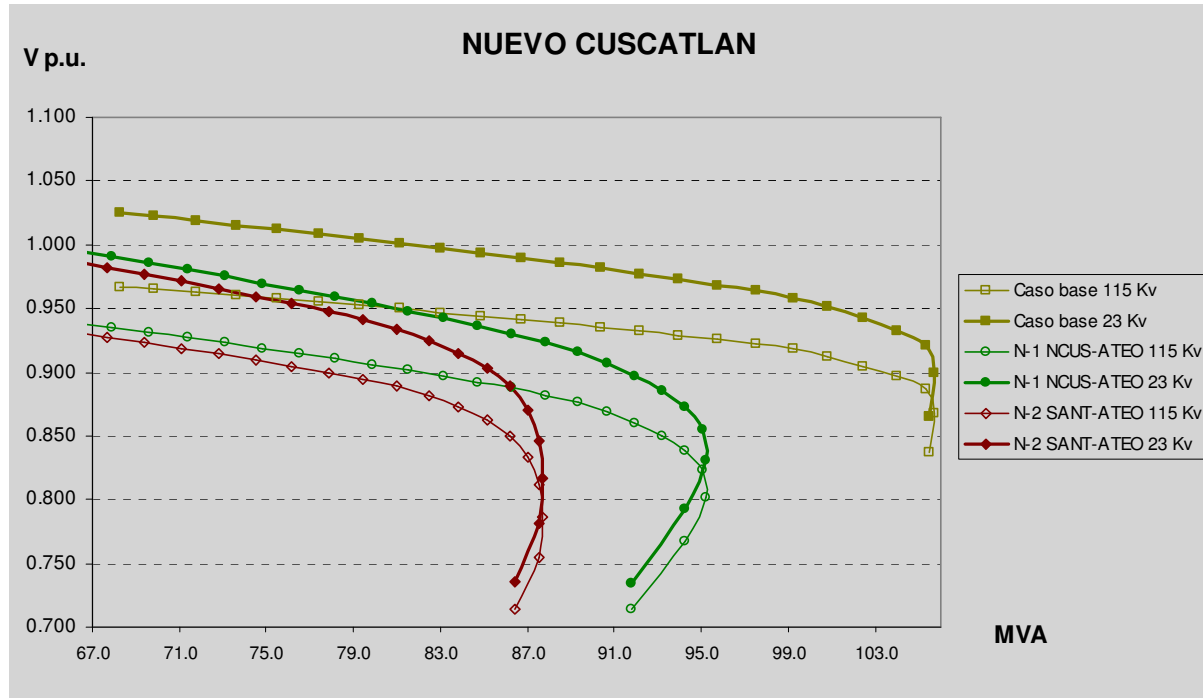

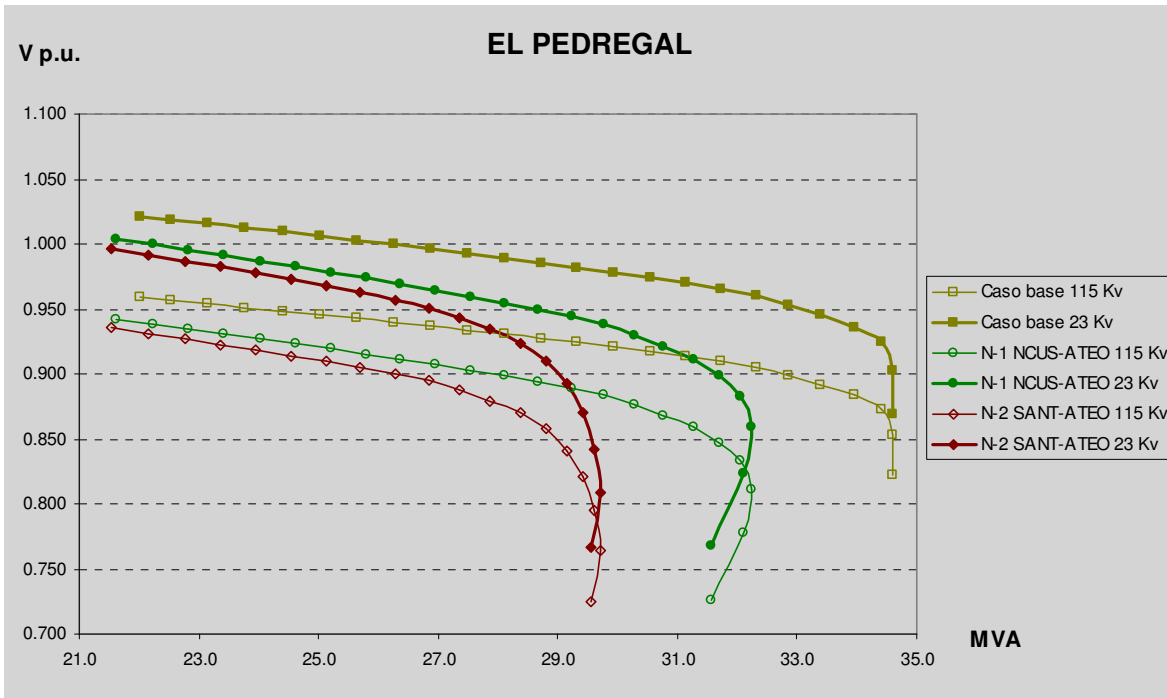

4.4.9. Caso 9: SANT-NEJA & ACAJ-ATEO

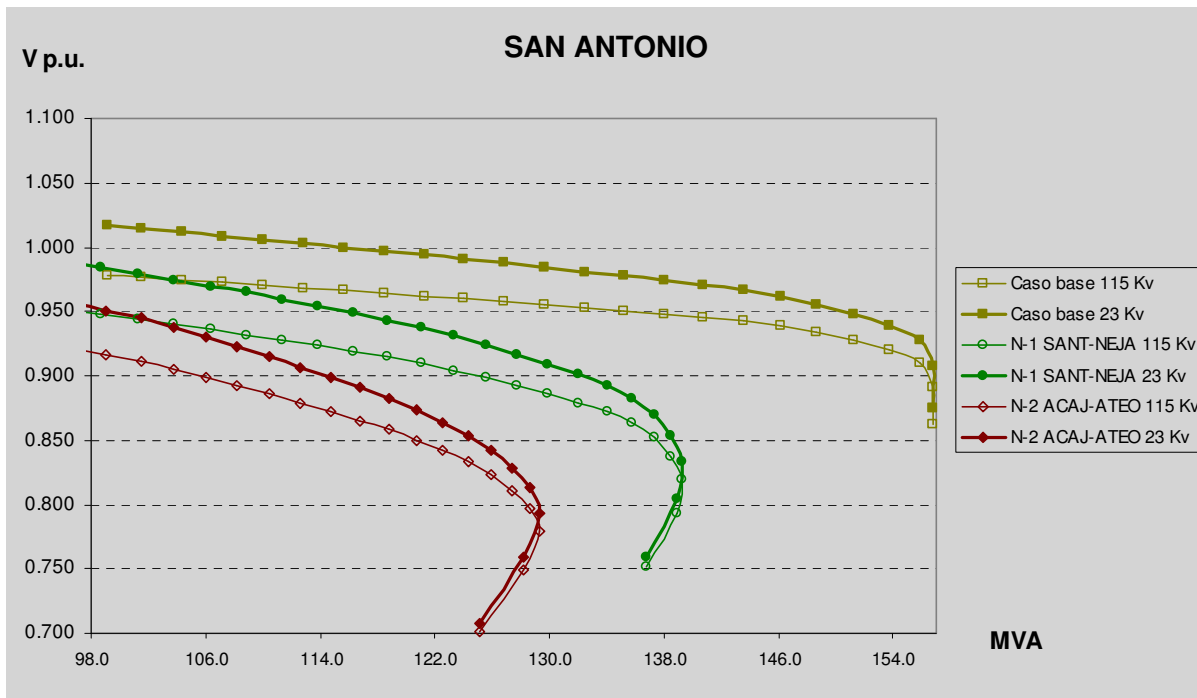

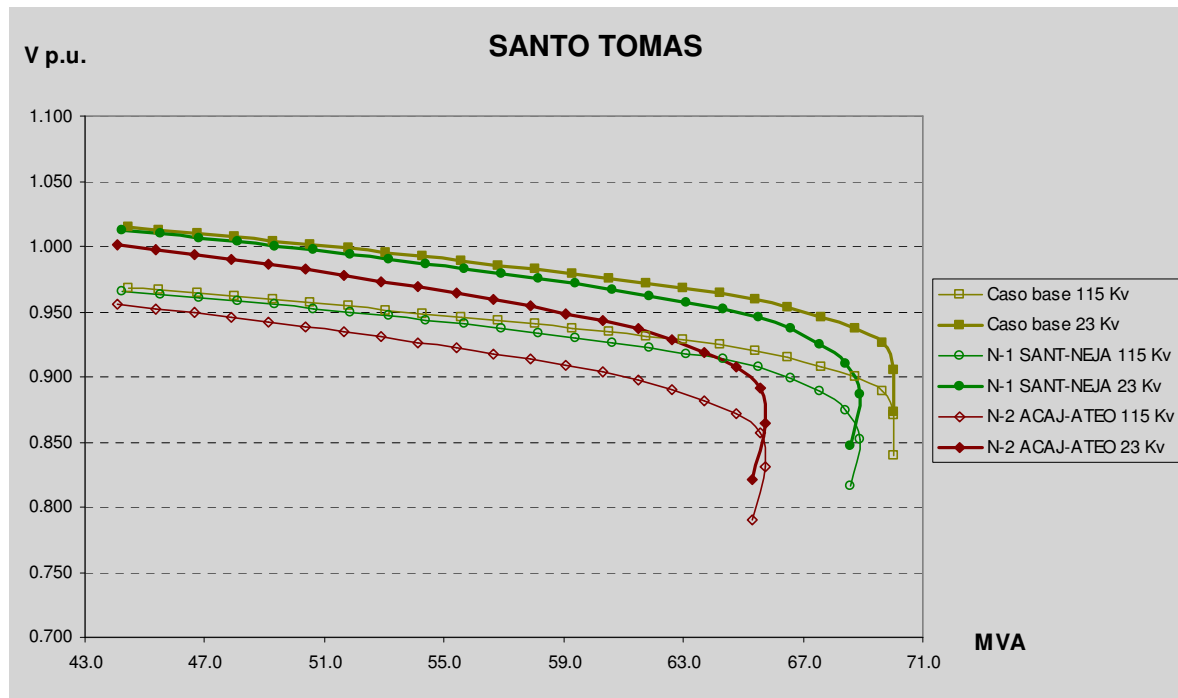
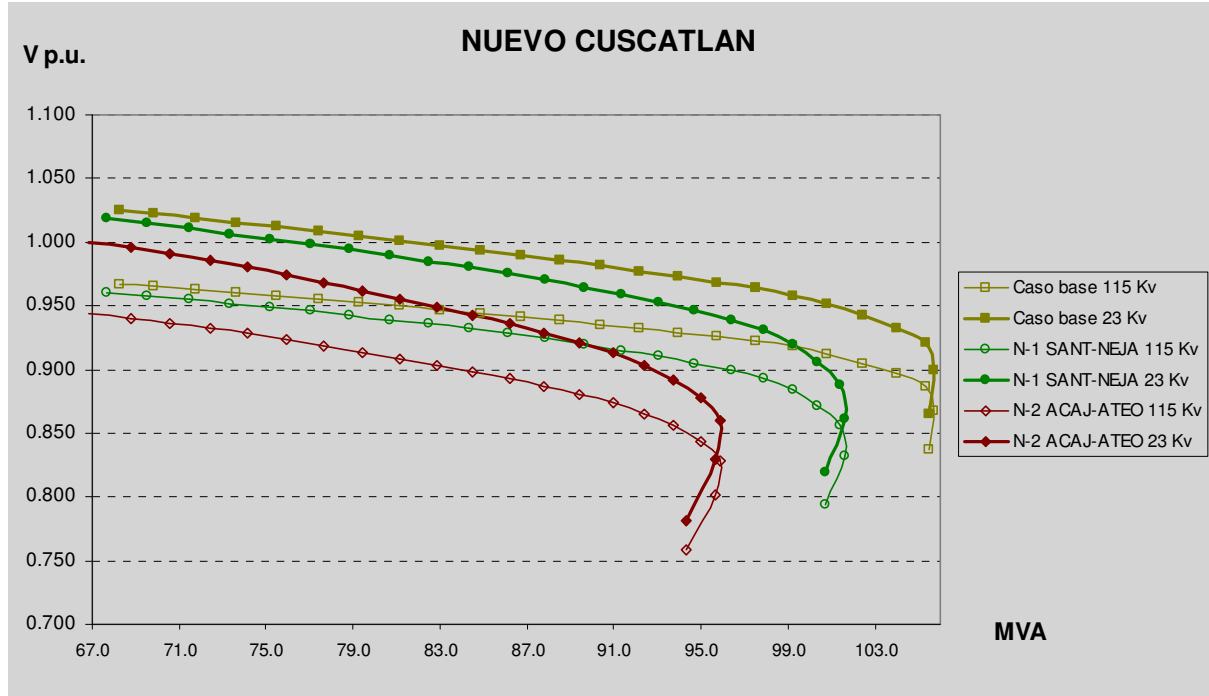

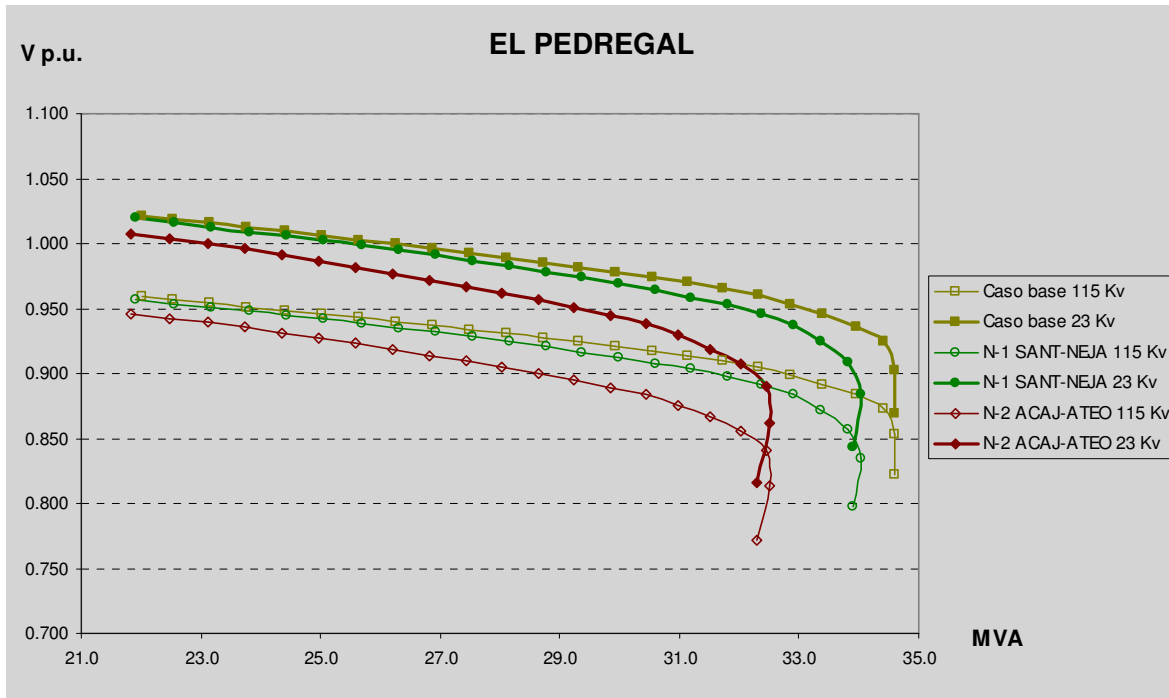

4.5. Análisis de las curvas PV

Caso	SUB	Punto de Colapso		Punto de Recuperación			Disparo para el presente escenario		Punto de disparo en condición N-1				Punto de disparo en condición N-2			
	SUB	V_{N-1}^C	P^C	V_{N-1}^R	V_{N-2}^R	P^R	P_{actual}	P_{shed}	P^F	V_{N-1}^F	Punto N-1	%L _F	P^S	V_{N-1}^S	Punto N-2	%L _F
BERL-SMIG & SMIG-OZAT	PEDR	0.869	34	0.902	0.902	32	27		32.3	0.902	15	0.9%	32	0.902	17	0.0%
	TECO	0.9	18.8	0.934	0.948	16	14		17.9	0.925	18	10.4%	17	0.942	15	5.9%
	OZAT	0.856	21	0.9	0.931	19	17		20.0	0.895	16	4.8%	21	0.909	20	9.5%
	SMIG	0.839	85	0.926	0.904	64	69	5	80.8	0.873	17	20.7%	73.5	0.901	13	12.9%
SMAR-STOM & ACAJ-ATEO	NCUS	0.801	94	0.929	0.909	66	76	7	89.3	0.866	15	26.1%	79	0.899	4	16.5%
	STOM	0.796	60	0.925	0.9	41	49	8	57.0	0.845	15	28.1%	48	0.897	10	14.6%
	PEDR	0.78	30	0.92	0.91	19	27	7	28.5	0.831	15	33.3%	22	0.896	10	13.6%
SRAF-TECO & 15SE-U1	SMIG	0.858	92	0.953	0.902	71	69		87.4	0.91	19	18.8%	79.2	0.938	17	10.4%
	OZAT	0.84	21	0.942	0.902	15	17	2	20.0	0.888	17	24.8%	19	0.9	16	21.1%
	TECO	0.825	18	0.918	0.9	12	14	2	17.1	0.859	19	29.8%	16	0.893	18	25.0%
SRAF-TECO & NCUS-ATEO	SMIG	0.858	92	0.92	0.902	85	69		87.4	0.91	19	2.7%	89	0.899	16	4.5%
	TECO	0.825	17	0.91	0.905	14	14		16.2	0.888	15	13.3%	15	0.898	13	6.7%
	OZAT	0.84	21	0.913	0.906	18	17		20.0	0.888	17	9.8%	19	0.9	15	5.3%
SMAR-STOM & ACAJ-U5	NCUS	0.801	94	0.909	0.900	76	76		89.3	0.869	15	14.9%	79	0.899	14	3.8%
	STOM	0.776	60	0.91	0.905	44	49	5	57.0	0.84	15	22.8%	48	0.897	15	8.3%
	PEDR	0.78	30	0.906	0.91	20	27	6	28.5	0.824	16	29.8%	23	0.896	15	13.0%
BERL-SMIG & 15SE-U1	TECO	0.866	19	0.92	0.901	17	14		18.1	0.911	18	5.8%	17.2	0.925	19	1.2%
	OZAT	0.856	21	0.915	0.901	18	17		20.0	0.895	16	9.8%	18.7	0.909	16	3.7%
	SMIG	0.839	85	0.917	0.902	68	69	1	80.8	0.873	17	15.8%	76	0.892	17	10.5%
SRAF-TECO & 15SE-SMIG	SMIG	0.858	91	0.956	0.908	69	69		86.5	0.914	18	20.2%	67	0.959	8	-3.0%
	OZAT	0.84	21	0.946	0.902	15	17	2	20.0	0.888	17	24.8%	19	0.9	8	21.1%
	TECO	0.825	17	0.941	0.9	12	14	2	16.2	0.881	16	25.7%	15	0.898	7	20.0%
NCUS-ATEO & SANT-ATEO	STOM	0.828	65	0.919	0.905	54	49		61.8	0.891	16	12.6%	60	0.898	12	10.0%
	PEDR	0.812	32	0.915	0.902	26	27	1	30.4	0.883	15	14.5%	28	0.899	11	7.1%
	NCUS	0.802	95	0.915	0.903	76	76		90.3	0.872	16	15.8%	83	0.897	12	8.4%
SANT-NEJA & ACAJ-ATEO	STOM	0.852	69	0.926	0.903	60	49		65.6	0.907	18	8.5%	59.1	0.93	13	-1.5%
	NCUS	0.856	101	0.936	0.904	83	76		96.0	0.9	17	13.5%	84.5	0.932	10	1.8%
	PEDR	0.835	34	0.925	0.904	28	27		32.3	0.892	18	13.3%	29.1	0.917	13	3.8%
	SANT	0.819	139	0.94	0.905	104	108	4	132.1	0.879	16	21.2%	126	0.898	9	17.5%

Las siguientes cantidades son identificadas a partir de las curvas P-V para obtener los parámetros de las curvas P-V:

Donde:

- Punto de colapso de la curva P-V, corresponde con el par ordenado V_{N-1}^C, P^C ;
- Punto de recuperación de la curva P-V, corresponde a la tríada V_{N-1}^R, V_{N-2}^R , y P^R , los cuales son el voltaje de recuperación sobre la curva P-V en condición N-1, voltaje de recuperación de la curva P-V en condición N-2 y Potencia del punto de recuperación, respectivamente.
- Punto mínimo de operación de disparo en condición N-1 que corresponde al par P^F, V_{N-1}^F y Punto N-1, los cuales son potencia, voltaje sobre la curva P-V y punto N-1, es el número de incremento en la secuencia de construcción de la curva P-V.
- Punto de mínimo de operación de disparo en condición N-2 que corresponde al par P^S, V_{N-1}^S y Punto N-2, es el número de incremento en la secuencia de construcción de la curva P-V.
- La condición de Punto N-1 o Punto N-2, da la indicación de orden de ocurrencia.

Los resultados por subestación son los siguientes:

Nuevo Cuscatlan

Caso	Punto de Colapso		Punto de Recuperación			Disparo para el presente escenario		Punto de disparo en condición N-1			Punto de disparo en condición N-2		
	V_{N-1}^C	P^C	V_{N-1}^R	V_{N-2}^R	P^R	P_{actual}	P_{shed}	P^F	V_{N-1}^F	$\%L_F$	P^S	V_{N-1}^S	$\%L_F$
SMAR-STOM & ACAJ-ATEO	0.801	94	0.929	0.909	66	76	7	89.3	0.866	26.1%	79	0.899	16.5%
SMAR-STOM & ACAJ-U5	0.801	94	0.909	0.900	76	76		89.3	0.869	14.9%	79	0.899	3.8%
NCUS-ATEO & SANT-ATEO	0.802	95	0.915	0.903	76	76		90.3	0.872	15.8%	83	0.897	8.4%
SANT-NEJA & ACAJ-ATEO	0.856	101	0.936	0.904	83	76		96.0	0.9	13.5%	84.5	0.932	1.8%

San Antonio Abad

Caso	Punto de Colapso		Punto de Recuperación			Disparo para el presente escenario		Punto de disparo en condición N-1			Punto de disparo en condición N-2		
	V_{N-1}^C	P^C	V_{N-1}^R	V_{N-2}^R	P^R	P_{actual}	P_{shed}	P^F	V_{N-1}^F	$\%L_F$	P^S	V_{N-1}^S	$\%L_F$
SANT-NEJA & ACAJ-ATEO	0.819	139	0.94	0.905	104	108	4	132.1	0.879	21.2%	126	0.898	17.5%

Santo Tomás

Caso	Punto de Colapso		Punto de Recuperación			Disparo para el presente escenario		Punto de disparo en condición N-1			Punto de disparo en condición N-2		
	V_{N-1}^C	P^C	V_{N-1}^R	V_{N-2}^R	P^R	P_{actual}	P_{shed}	P^F	V_{N-1}^F	$\%L_F$	P^S	V_{N-1}^S	$\%L_F$
SMAR-STOM & ACAJ-ATEO	0.796	60	0.925	0.9	41	49	8	57.0	0.845	28.1%	48	0.897	14.6%
SMAR-STOM & ACAJ-U5	0.776	60	0.91	0.905	44	49	5	57.0	0.84	22.8%	48	0.897	8.3%
NCUS-ATEO & SANT-ATEO	0.828	65	0.919	0.905	54	49		61.8	0.891	12.6%	60	0.898	10.0%
SANT-NEJA & ACAJ-ATEO	0.852	69	0.926	0.903	60	49		65.6	0.907	8.5%	59.1	0.930	-1.5%

El Pedregal

Caso	Punto de Colapso		Punto de Recuperación			Disparo para el presente escenario		Punto de disparo en condición N-1			Punto de disparo en condición N-2		
	V_{N-1}^C	P^C	V_{N-1}^R	V_{N-2}^R	P^R	P_{actual}	P_{shed}	P^F	V_{N-1}^F	$\%L_F$	P^S	V_{N-1}^S	$\%L_F$
BERL-SMIG & SMIG-OZAT	0.869	34	0.902	0.902	32	27		32.3	0.902	0.9%	32	0.902	0.0%
SMAR-STOM & ACAJ-ATEO	0.78	30	0.92	0.91	19	27	7	28.5	0.831	33.3%	22	0.896	13.6%
SMAR-STOM & ACAJ-U5	0.78	30	0.906	0.91	20	27	6	28.5	0.824	29.8%	23	0.896	13.0%
NCUS-ATEO & SANT-ATEO	0.812	32	0.915	0.902	26	27	1	30.4	0.883	14.5%	28	0.899	7.1%
SANT-NEJA & ACAJ-ATEO	0.835	34	0.925	0.904	28	27		32.3	0.892	13.3%	29.1	0.917	3.8%

San Miguel

Caso	Punto de Colapso		Punto de Recuperación			Disparo para el presente escenario		Punto de disparo en condición N-1			Punto de disparo en condición N-2		
	V_{N-1}^C	P^C	V_{N-1}^R	V_{N-2}^R	P^R	P_{actual}	P_{shed}	P^F	V_{N-1}^F	$\%L_F$	P^S	V_{N-1}^S	$\%L_F$
BERL-SMIG & SMIG-OZAT	0.839	85	0.926	0.904	64	69	5	80.8	0.873	20.7%	73.5	0.901	12.9%
SRAF-TECO & 15SE-U1	0.858	92	0.953	0.902	71	69		87.4	0.91	18.8%	79.2	0.938	10.4%
SRAF-TECO & NCUS-ATEO	0.858	92	0.92	0.902	85	69		87.4	0.91	2.7%	89	0.899	4.5%
BERL-SMIG & 15SE-U1	0.839	85	0.917	0.902	68	69	1	80.8	0.873	15.8%	76	0.892	10.5%
SRAF-TECO & 15SE-SMIG	0.858	91	0.956	0.908	69	69		86.5	0.914	20.2%	67	0.959	-3.0%

Ozatlan

Caso	Punto de Colapso		Punto de Recuperación			Disparo para el presente escenario		Punto de disparo en condición N-1			Punto de disparo en condición N-2		
	V_{N-1}^C	P^C	V_{N-1}^R	V_{N-2}^R	P^R	P_{actual}	P_{shed}	P^F	V_{N-1}^F	$\%L_F$	P^S	V_{N-1}^S	$\%L_F$
BERL-SMIG & SMIG-OZAT	0.856	21	0.9	0.931	19	17		20.0	0.895	4.8%	21	0.909	9.5%
SRAF-TECO & 15SE-U1	0.84	21	0.942	0.902	15	17	2	20.0	0.888	24.8%	19	0.9	21.1%
SRAF-TECO & NCUS-ATEO	0.84	21	0.913	0.906	18	17		20.0	0.888	9.8%	19	0.9	5.3%
BERL-SMIG & 15SE-U1	0.856	21	0.915	0.901	18	17		20.0	0.895	9.8%	18.7	0.909	3.7%
SRAF-TECO & 15SE-SMIG	0.84	21	0.946	0.902	15	17	2	20.0	0.888	24.8%	19	0.9	21.1%

Tecoluca

Caso	Punto de Colapso		Punto de Recuperación			Disparo para el presente escenario		Punto de disparo en condición N-1			Punto de disparo en condición N-2		
	V_{N-1}^C	P^C	V_{N-1}^R	V_{N-2}^R	P^R	P_{actual}	P_{shed}	P^F	V_{N-1}^F	$\%L_F$	P^S	V_{N-1}^S	$\%L_F$
BERL-SMIG & SMIG-OZAT	0.9	18.8	0.934	0.948	16	14		17.9	0.925	10.4%	17	0.942	5.9%
SRAF-TECO & 15SE-U1	0.825	18	0.918	0.9	12	14	2	17.1	0.859	29.8%	16	0.893	25.0%
SRAF-TECO & NCUS-ATEO	0.825	17	0.91	0.905	14	14		16.2	0.888	13.3%	15	0.898	6.7%
BERL-SMIG & 15SE-U1	0.866	19	0.92	0.901	17	14		18.1	0.911	5.8%	17.2	0.925	1.2%
SRAF-TECO & 15SE-SMIG	0.825	17	0.941	0.9	12	14	2	16.2	0.881	25.7%	15	0.898	20.0%

Un resumen analítico de los voltajes mínimo de operación de disparo se muestra en la siguiente tabla, en la cual, se tiene identificado dos grupos de cargas y el voltaje asociado en cada caso para cada nodo:

V_{N-1}^F	SMIG	OZAT	TECO	NCUS	STOM	PEDR	SANT
BERL-SMIG & 15SE-U1	0.873	0.895	0.911				
BERL-SMIG & SMIG-OZAT	0.873	0.895	0.925				
SRAF-TECO & 15SE-SMIG	0.914	0.888	0.881				
SRAF-TECO & 15SE-U1	0.91	0.888	0.859				
SRAF-TECO & NCUS-ATEO	0.91	0.888	0.888				
NCUS-ATEO & SANT-ATEO				0.872	0.891	0.883	
SANT-NEJA & ACAJ-ATEO				0.9	0.907	0.892	0.879
SMAR-STOM & ACAJ-ATEO				0.866	0.845	0.831	
SMAR-STOM & ACAJ-U5				0.869	0.84	0.824	

V_{N-1}^S	SMIG	OZAT	TECO	NCUS	STOM	PEDR	SANT
BERL-SMIG & 15SE-U1	0.892	0.909	0.925				
BERL-SMIG & SMIG-OZAT	0.901	0.909	0.942				
SRAF-TECO & 15SE-SMIG	0.959	0.9	0.898				
SRAF-TECO & 15SE-U1	0.938	0.9	0.893				
SRAF-TECO & NCUS-ATEO	0.899	0.9	0.898				
NCUS-ATEO & SANT-ATEO				0.897	0.898	0.899	
SANT-NEJA & ACAJ-ATEO				0.932	0.93	0.917	0.898
SMAR-STOM & ACAJ-ATEO				0.899	0.897	0.896	
SMAR-STOM & ACAJ-U5				0.899	0.897	0.896	

Se ajusta el disparo de las etapas en cada nodo disparando carga para el peor de los casos; es decir, los porcentajes de carga asignados corresponde al peor de los casos. Los voltajes V^S y V^F se seleccionan talque $V^F < V^S$ & $V^S \leq 0.9$ (la idea es la de tratar de mantenerse por debajo de la banda de voltaje de emergencia cuando sea posible), y el valor seleccionado de V^F ó V^S , que cubra o proteja la mayoría de los casos de contingencias. La coordinación del EDCBV será posible solamente con las pruebas de efectividad mediante simulaciones dinámicas.

EDBV	MEDIANA			RAPIDA		
	V_{N-1}^S	DELAY	%S ₂	V_{N-1}^F	DELAY	%S ₁
SANT	0.898	3	17.5	0.879	1.5	21.2
NCUS	0.899	3	16.5	0.872	1.5	26.1
SMIG	0.901	3	12.9	0.873	1.5	20.7
TECO	0.898	3	25.0	0.888	1.5	29.8
OZAT	0.909	3	21.1	0.888	1.5	24.8
STOM	0.897	3	14.6	0.845	1.5	28.1
PEDR	0.899	3	13.6	0.831	1.5	33.3

4.6. Determinación del tiempo de retardo para iniciar disparo de carga

Para determinar el tiempo de retardo, se simulará todas las contingencias simples y dobles críticas observadas para el presente escenario de demanda; se indica que el tiempo de retardo será el lapso después de que una falla es limpiada hasta que el voltaje alcance un valor estable.

4.6.1. Falla trifásica y disparo de línea BERL-SMIG

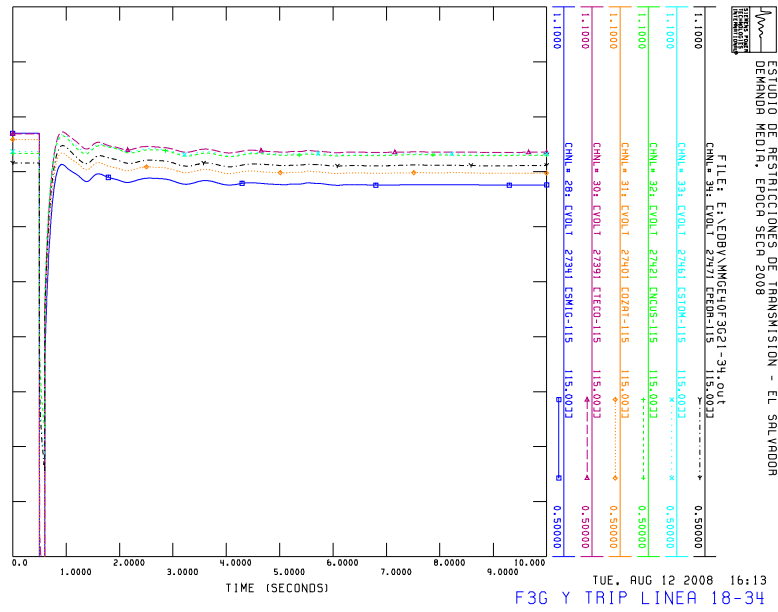

4.6.2. Falla trifásica y disparo de línea SRAF-TECO

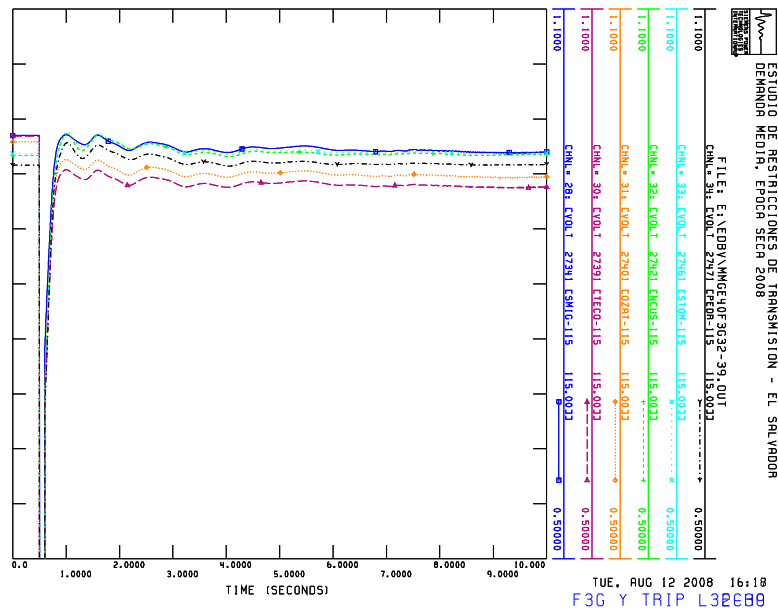

4.6.3. Falla trifásica y disparo de línea SANT-NEJA

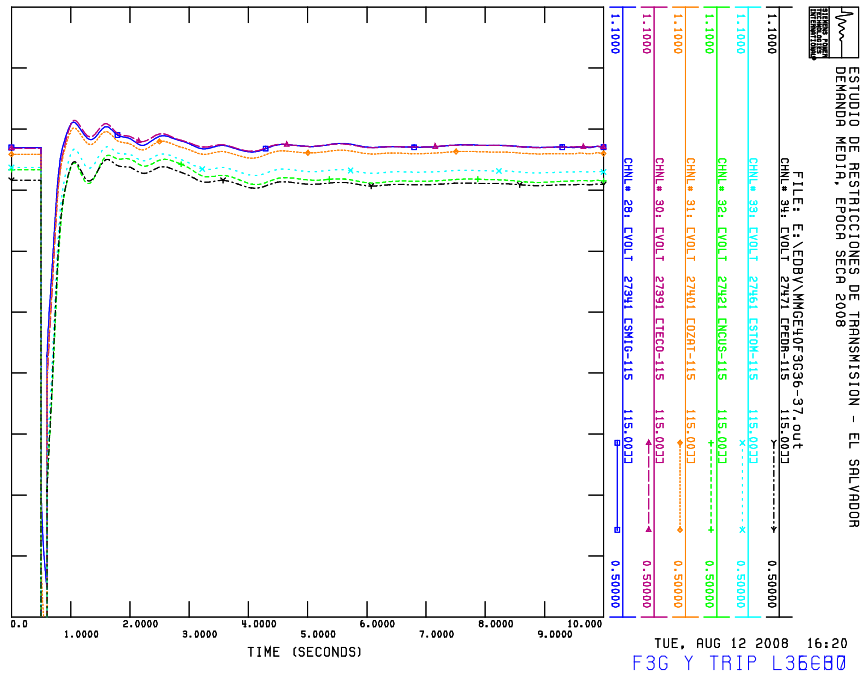

4.6.4. Falla trifásica y disparo de línea SMAR-STOM

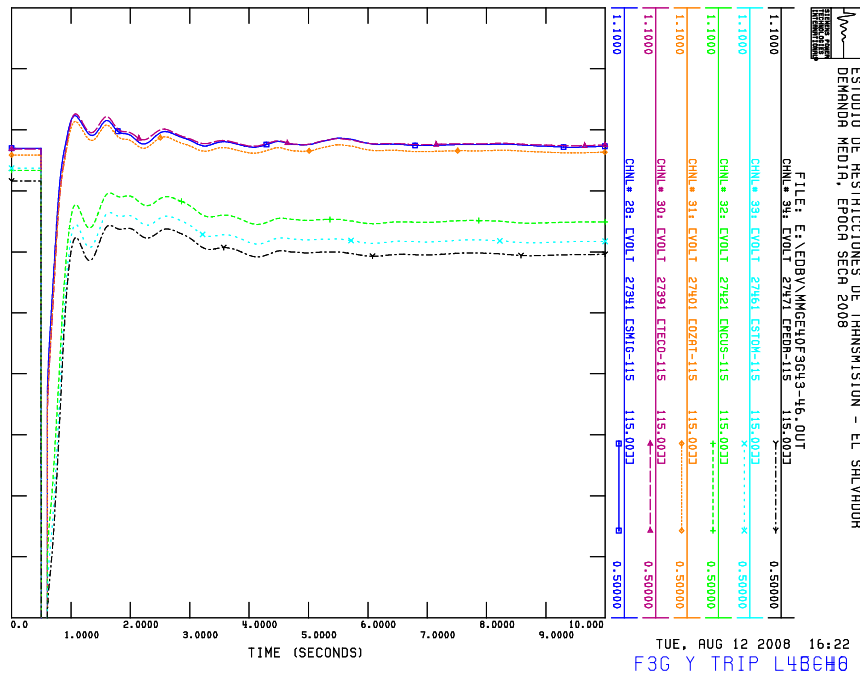

4.6.5. Falla triásica y disparo de línea BERL-SMIG y disparo de 15SE-UI

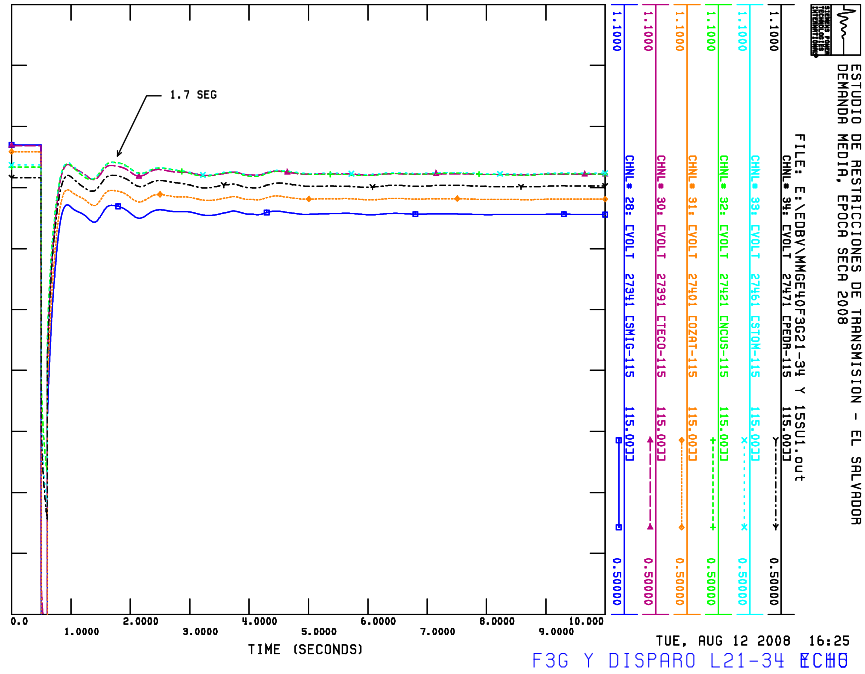

4.6.6. Falla trifásica en bus 115 kV de SMIG y disparo de líneas BERL-SMIG Y SMIG-OZAT

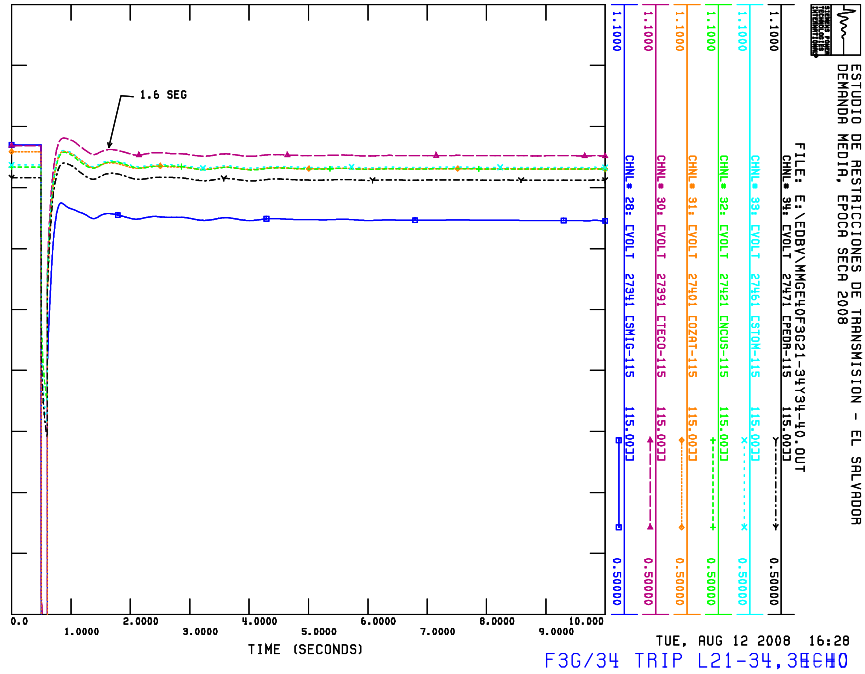

4.6.7. Falla trifásica en línea SRAF-TECO y disparo de SRAF-TECO Y 15SE-UI

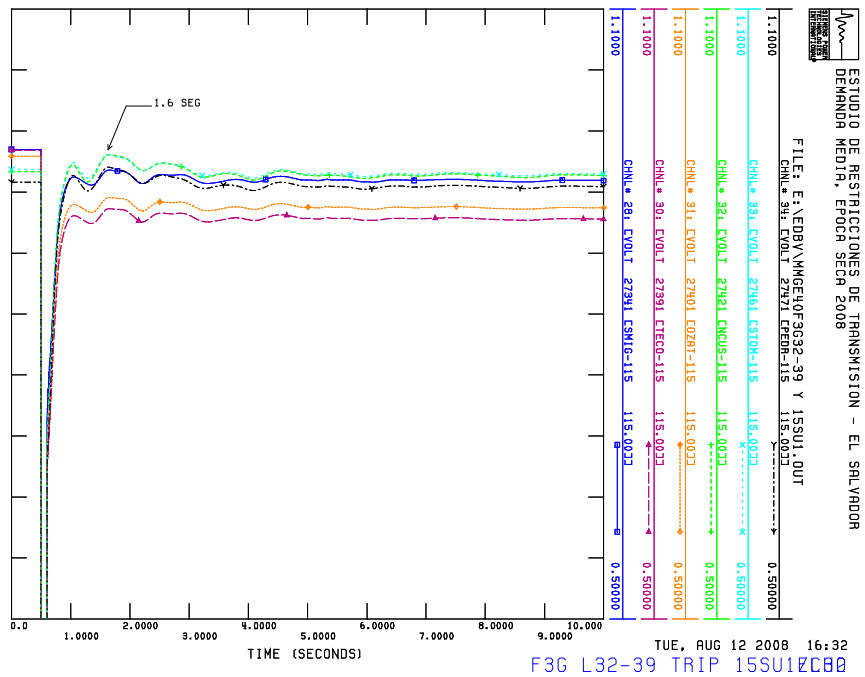

4.6.8. Falla trifásica en línea SRAF-15SE y disparo de líneas SRAF-TECO y 15SE-SMIG

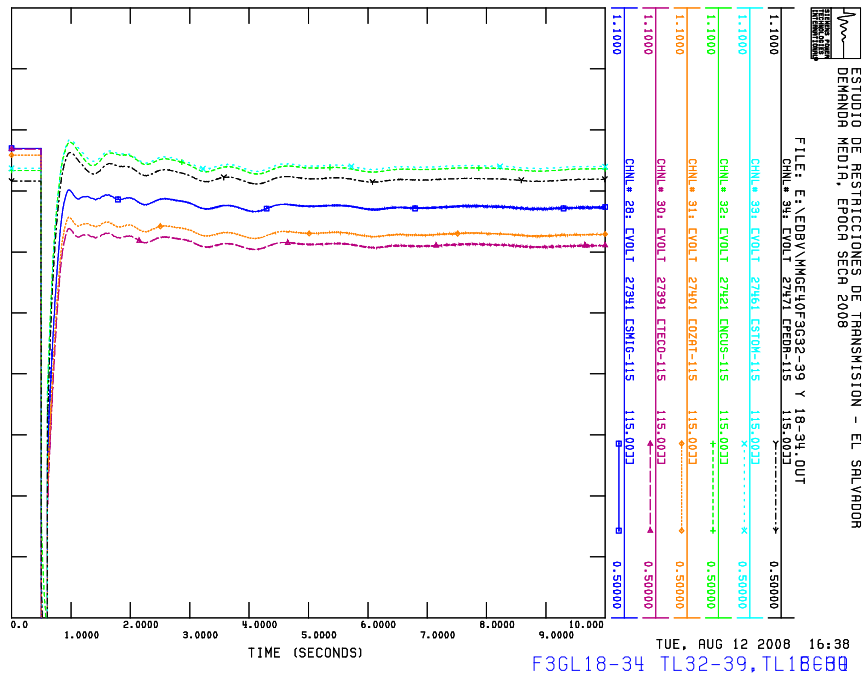

4.6.9. Falla trifásica y disparo línea SRAF-TECO, en mantenimiento NCUS-ATEO

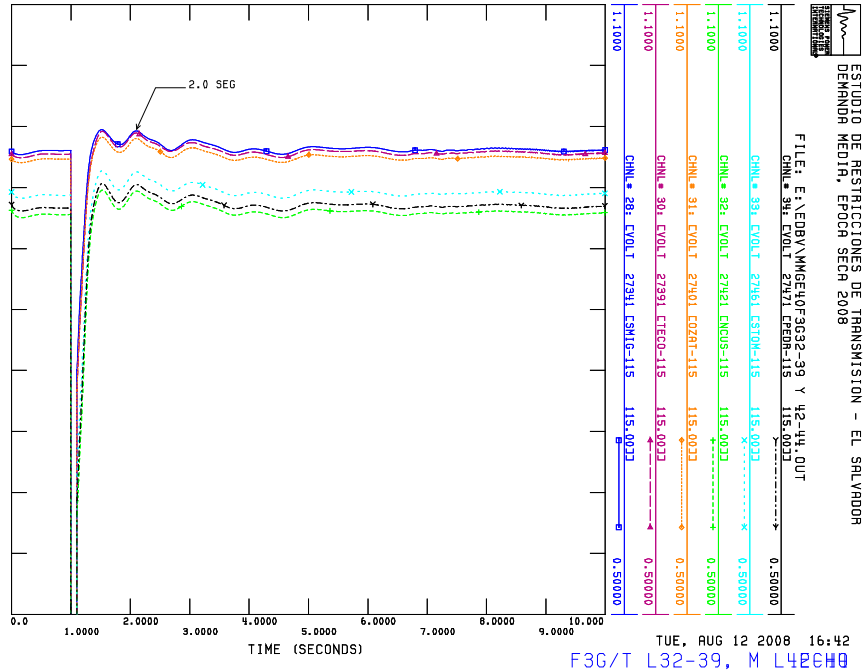

4.6.10. Falla trifásica en línea SANT-ATEO, disparo de líneas SANT-NEJA Y ACAJ-ATEO

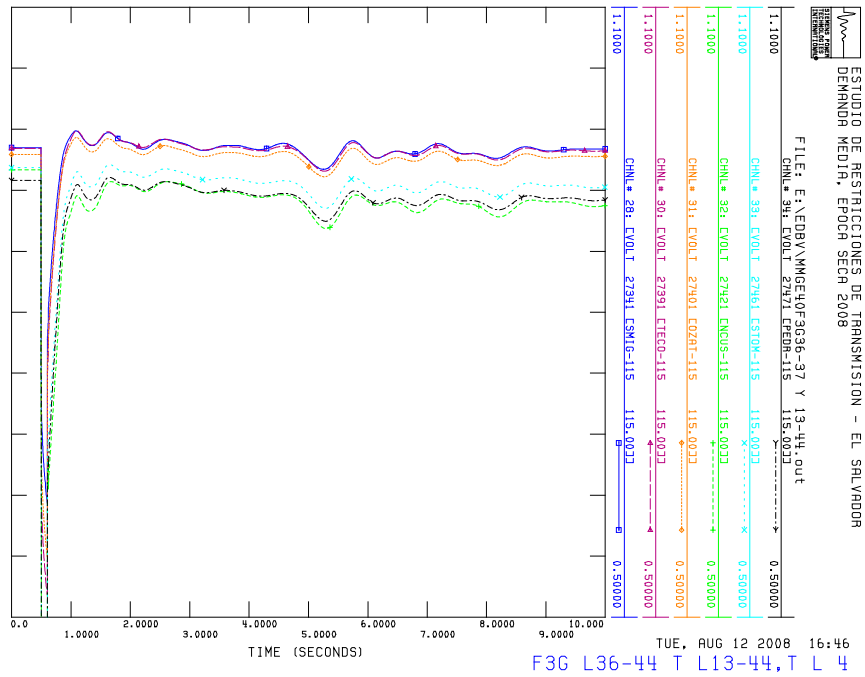

4.6.11. Falla trifásica en bus 115 kV de ATEO y disparo de líneas SANT-ATEO y NCUS-ATEO

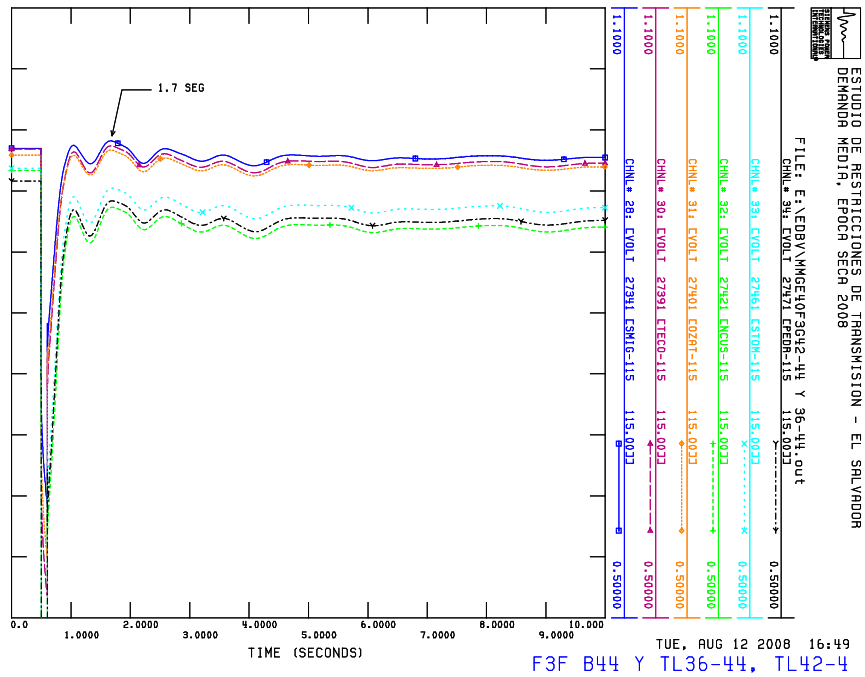

4.6.12. Falla trifásica y disparo de línea SMAR-STOM y disparo de ACAJ-U5

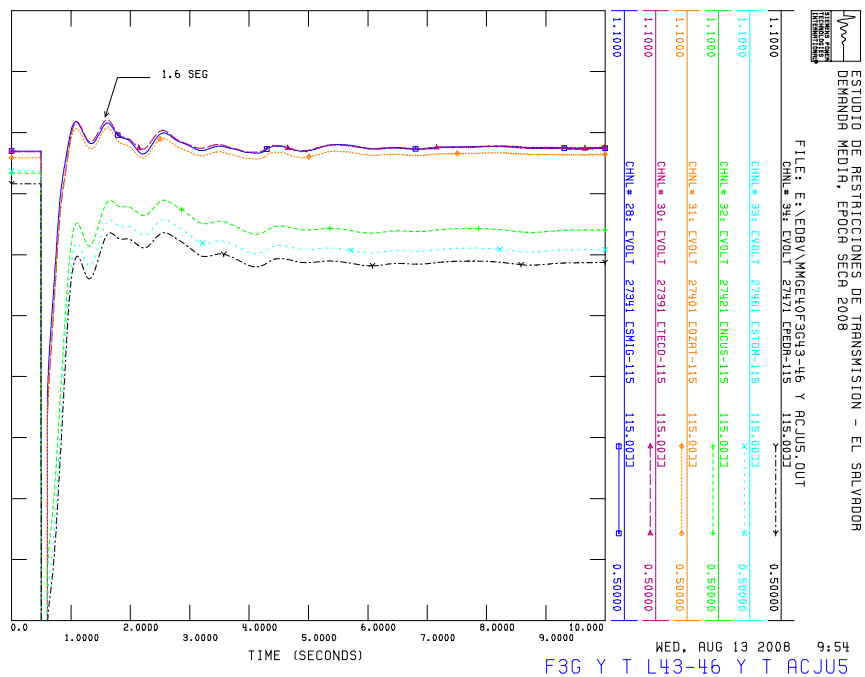

4.6.13. Falla trifásica en línea NCUS-ATEO, disparo de líneas ACAJ-ATEO y SMAR-STOM

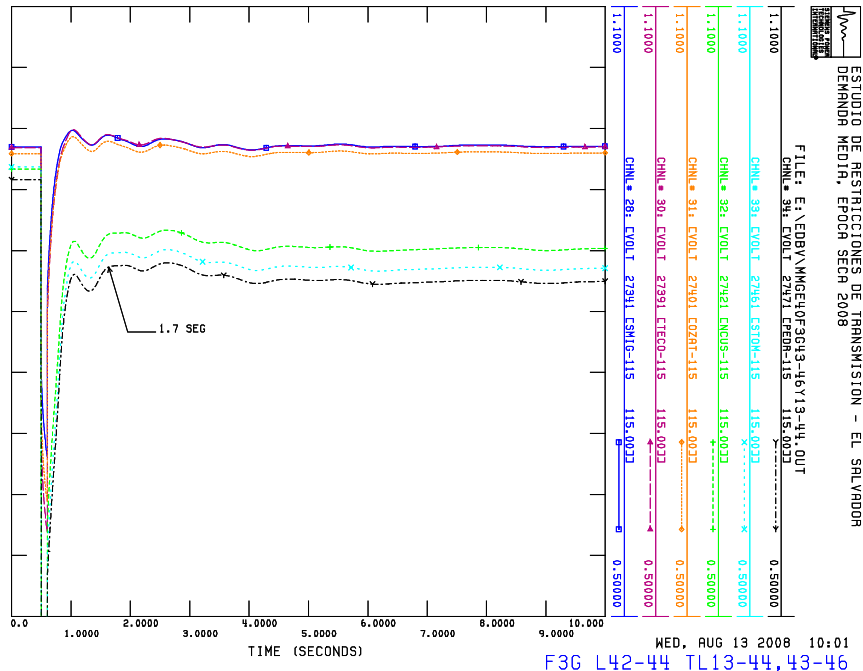

De las gráficas precedentes, se estima que la duración máxima de un disturbio es de 1.5 segundos; donde el transitorio mas larga corresponde a una falla trifásica en la línea SRAF-TECO con previa apertura de la línea NCUS-ATEO.

4.7. Verificación de parámetros con análisis en el dominio del tiempo del EDCBV

El objetivo es el de comprobar mediante simulaciones dinámicas, que los ajustes previos al EDBV obtenidos de las curvas P-V, son válidos; además, se harán los ajustes en la carga a disparar para llevar al sistema a las condiciones de recuperación.

4.7.1. *Falla trifásica y disparo de línea BERL-SMIG*

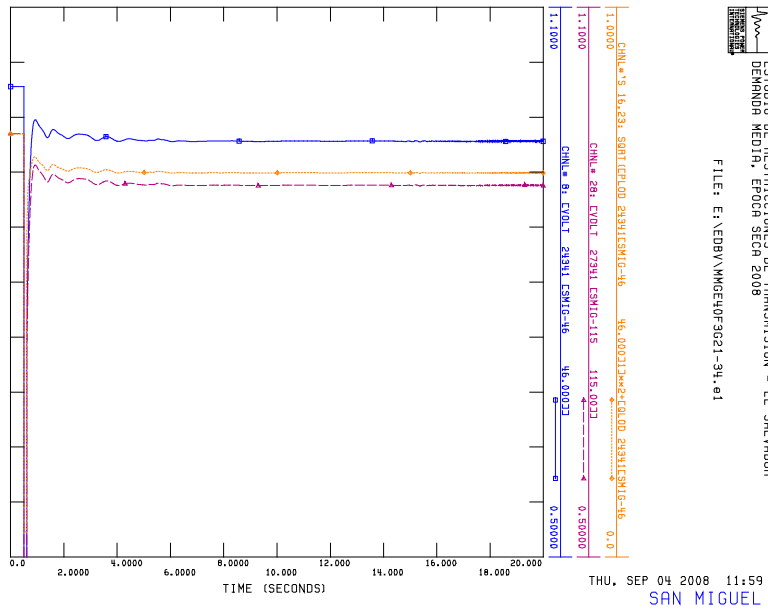

SUB	Disparo esperado	V _{ini}	S _{ini}	Etapa	V _{fin}	S _{fin}	ΔS	AJUSTE	
SMIG	0	0.903	69.7	x					
OZAT	0	0.921	17.4	x					
TECO	0	0.941	15.2	x					x

4.7.2. *Falla trifásica y disparo de línea SRAF-TECO*

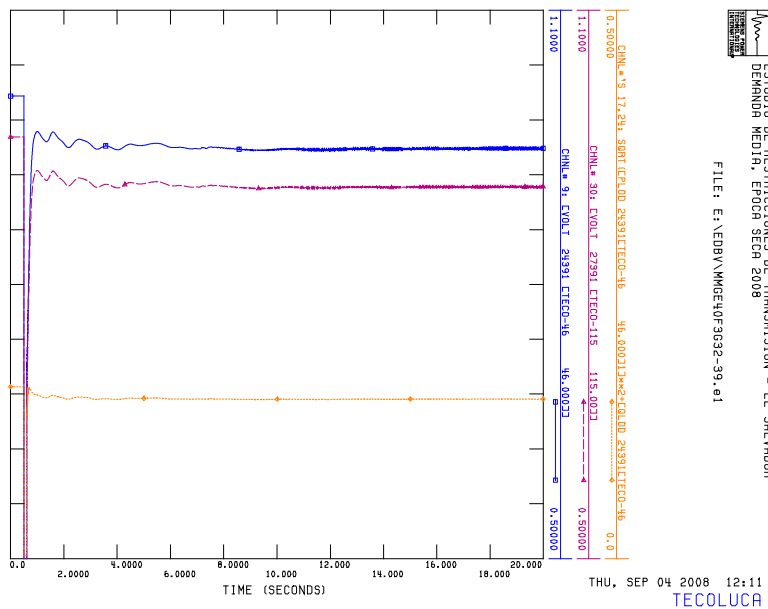

SUB	Disparo esperado	V _{ini}	S _{ini}	Etapa	V _{fin}	S _{fin}	ΔS	AJUSTE	
TECO	0	0.904	14.7	x					
OZAT	0	0.919	17.4	x					
SMIG	0	0.942	74.8	x					

4.7.3. Falla trifásica y disparo de línea SANT-NEJA

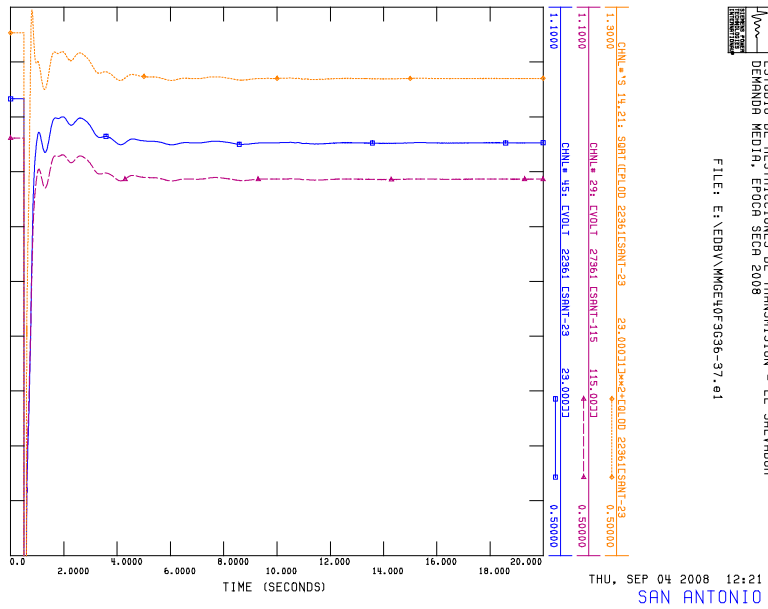

SUB	Disparo esperado	V _{ini}	S _{ini}	Etapa	V _{fin}	S _{fin}	ΔS	AJUSTE	
SANT	0	0.912	120	x					
PEDR	0	0.926	28.1	x					
STOM	0	0.939	56.3	x					
NCUS	0	0.927	85.9	x					

4.7.4. Falla trifásica y disparo de línea SMAR-STOM

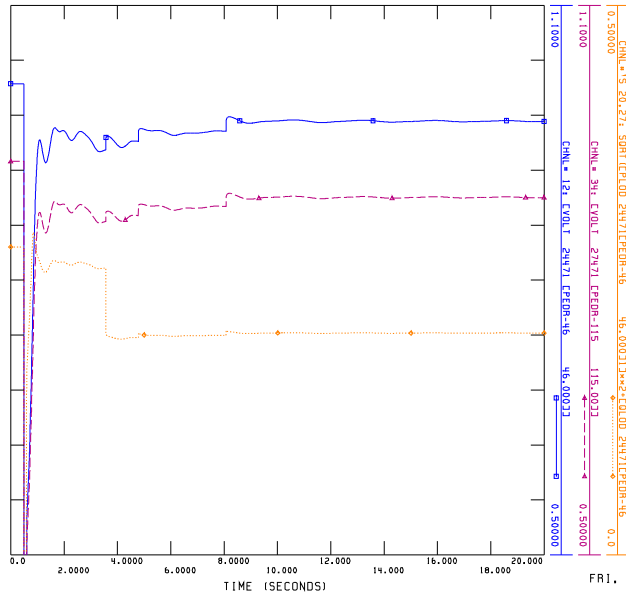

ESTUDIO DE RESTRICCIONES DE TRANSMISION - EL SALVADOR
DEMANDA MEDIA, EPOCA SECH 2008
FILE: E:\EDBY\WMOE40F3043-46.E1

FRI, SEP 05 2008 9:40
EL PEDREGAL

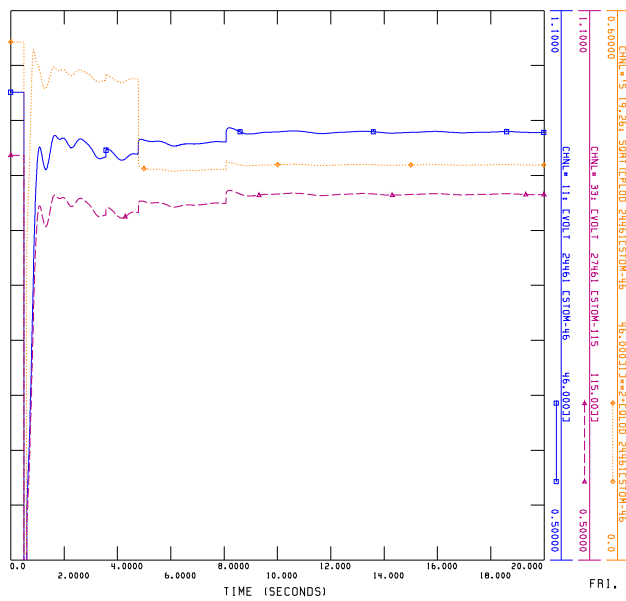

ESTUDIO DE RESTRICCIONES DE TRANSMISION - EL SALVADOR
DEMANDA MEDIA, EPOCA SECH 2008
FILE: E:\EDBY\WMOE40F3043-46.E1

FRI, SEP 05 2008 9:44
SANTO TOMAS

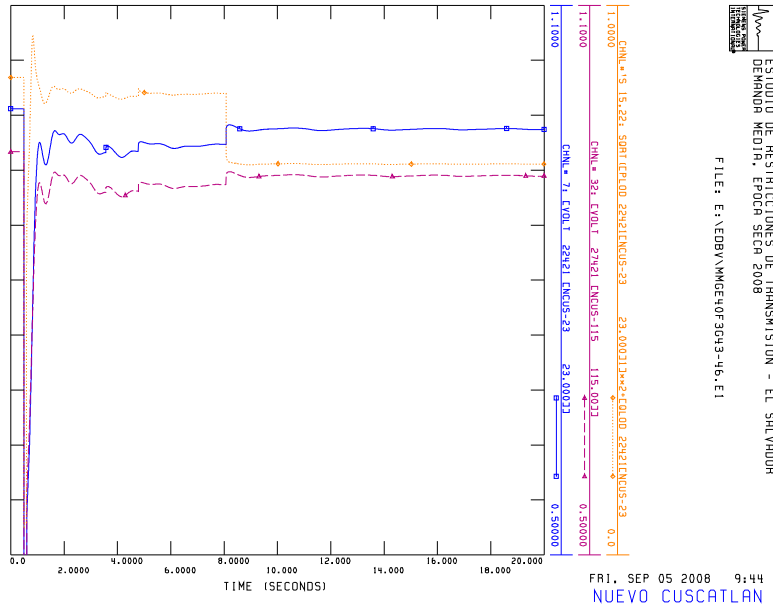

SUB	Disparo esperado	V _{ini}	S _{ini}	Etapa	V _{fin}	S _{fin}	ΔS	AJUSTE	
								%Ls	25%
PEDR	7	0.863	26.1	1	0.883	23.1	-3	%Ls	25%
STOM	8	0.878	52.5	1	0.895	45.7	-6.8	%Ls	20%
NCUS	7	0.894	83.5	1	0.91	70.8	-12.7	V _s	0.905

4.7.5. *Falla triásica y disparo de línea NCUS-ATEO y disparo*

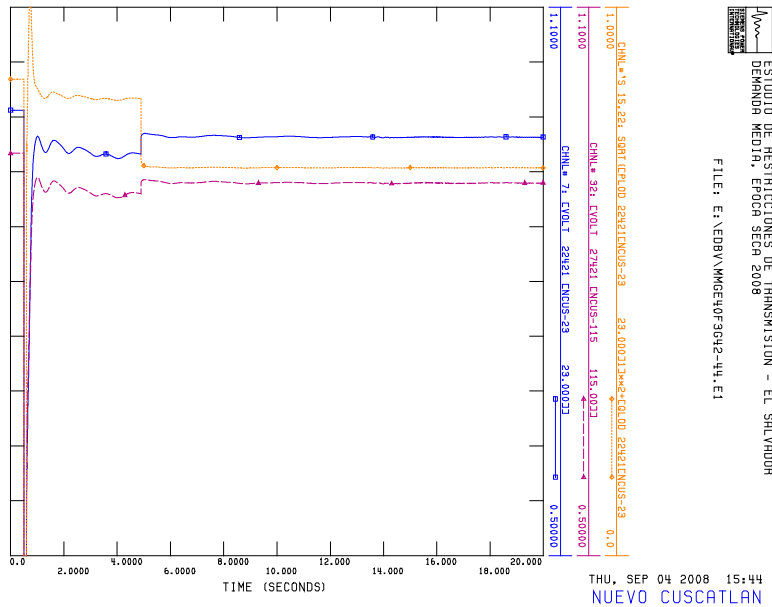

SUB	Disparo esperado	V _{ini}	S _{ini}	Etapa	V _{fin}	S _{fin}	ΔS	AJUSTE	
PEDR	1	0.904	27.3	x	0.909	27.4			
NCUS	0	0.896	83.4	1	0.908	70.8	-12.6		
STOM	0	0.916	54.9	x	0.921	55.2			

4.7.6. *Falla triásica y disparo de línea BERL-SMIG y disparo de 15SE-U1*

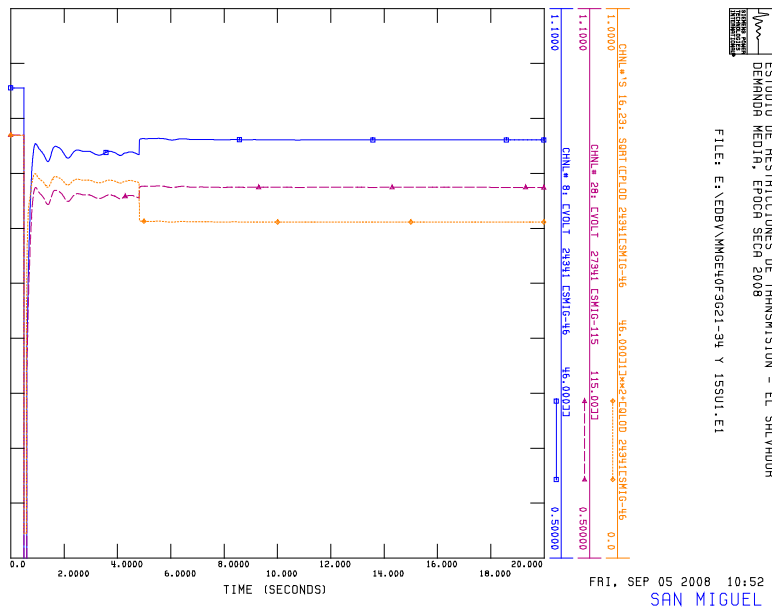

SUB	Disparo esperado	V _{ini}	S _{ini}	Etapa	V _{fin}	S _{fin}	ΔS	AJUSTE	
SMIG	1	0.894	68.8	1	0.907	61.2	-7.6		
OZAT	0	0.910	17.1	x	0.913	17.4			
TECO	0	0.935	15.2	x	0.937	15.2			

4.7.7. Falla trifásica en bus 115 kV de SMIG y disparo de líneas BERL-SMIG Y SMIG-OZAT

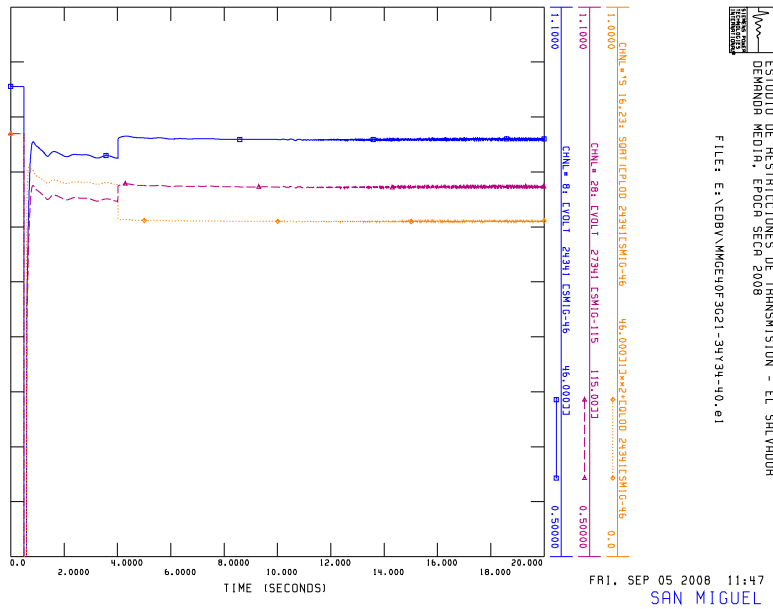

SUB	Disparo esperado	V _{ini}	S _{ini}	Etapa	V _{fin}	S _{fin}	ΔS	AJUSTE	
OZAT	0	0.939	18.1	x	0.937	18			
SMIG	5	0.888	67.9	1	0.903	61.2	-6.7		
TECO	0	0.954	15.5	x	0.952	15.5			

4.7.8. Falla trifásica en línea SRAF-TECO y disparo de SRAF-TECO Y 15SE-UI

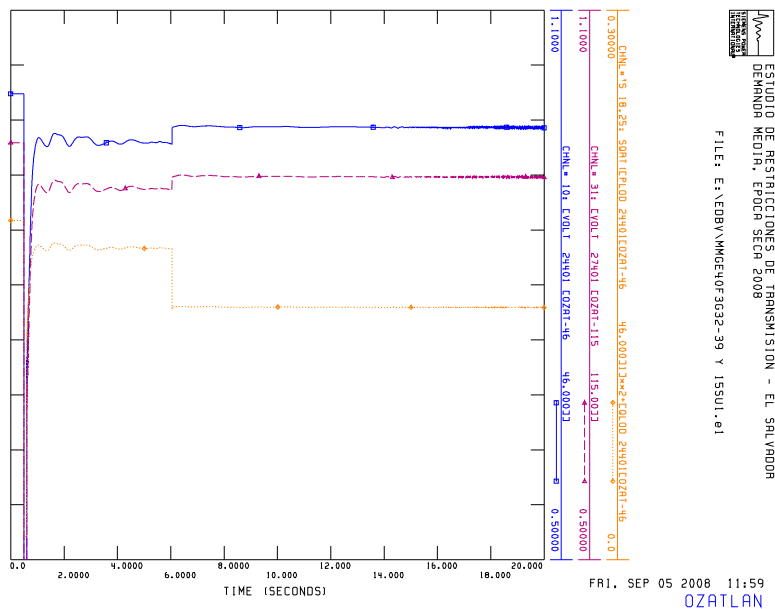
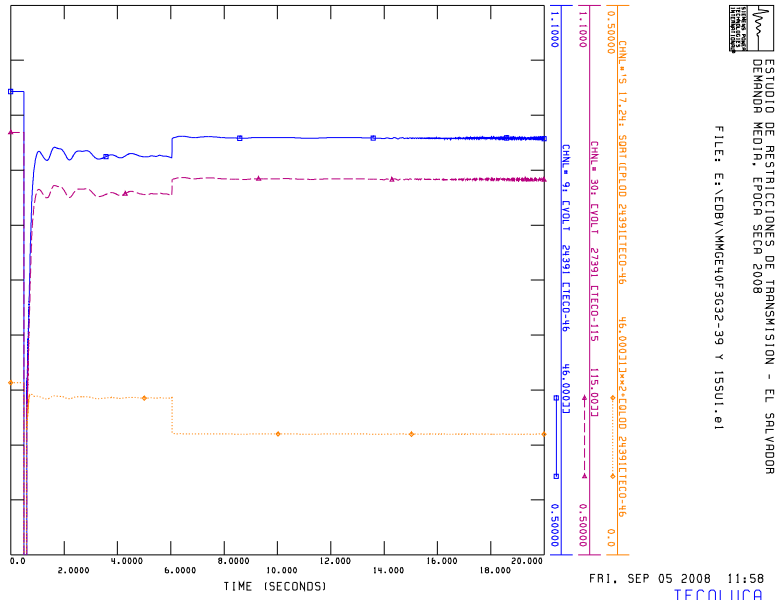

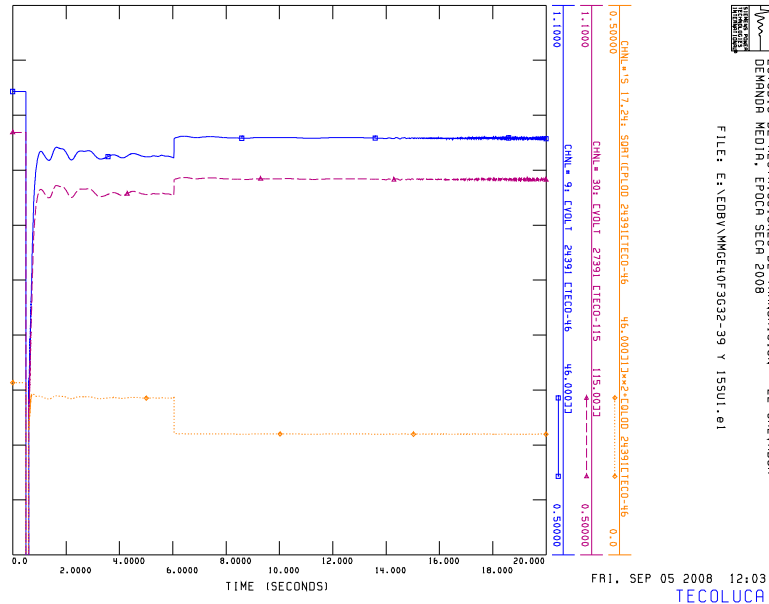

SUB	Disparo esperado	V _{ini}	S _{ini}	Etapa	V _{fin}	S _{fin}	ΔS	AJUSTE	
TECO	2	0.893	14.4	1	0.913	11.1	-3.3		
OZAT	2	0.905	17.1	1	0.919	13.9	-3.2		
SMIG	0	0.934	73.3	x	0.935	73.7			

4.7.9. Falla trifásica en línea SRAF-15SE y disparo de líneas SRAF-TECO y 15SE-SMIG

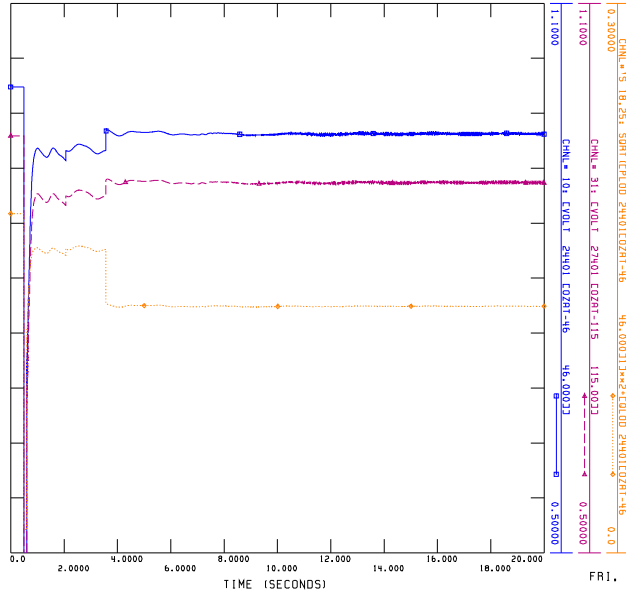

ESTUDIO DE RESTRICCIONES DE TRANSMISION - EL SALVADOR
 DEMANDA MEDIA, EPOCA SECA 2008
 FILE: E:\EDBY\WME40F3032-39 Y 18-34.e1

FRI, SEP 05 2008 14:33
 OZATLAN

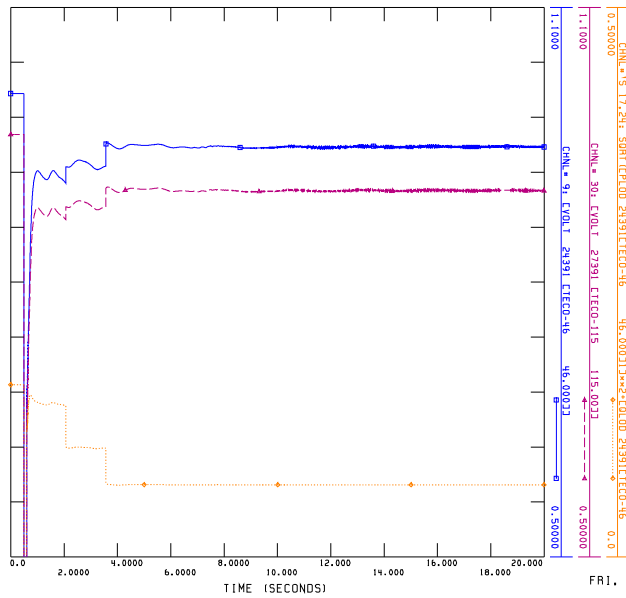

ESTUDIO DE RESTRICCIONES DE TRANSMISION - EL SALVADOR
 DEMANDA MEDIA, EPOCA SECA 2008
 FILE: E:\EDBY\WME40F3032-39 Y 18-34.e1

FRI, SEP 05 2008 14:32
 TECOLUCA

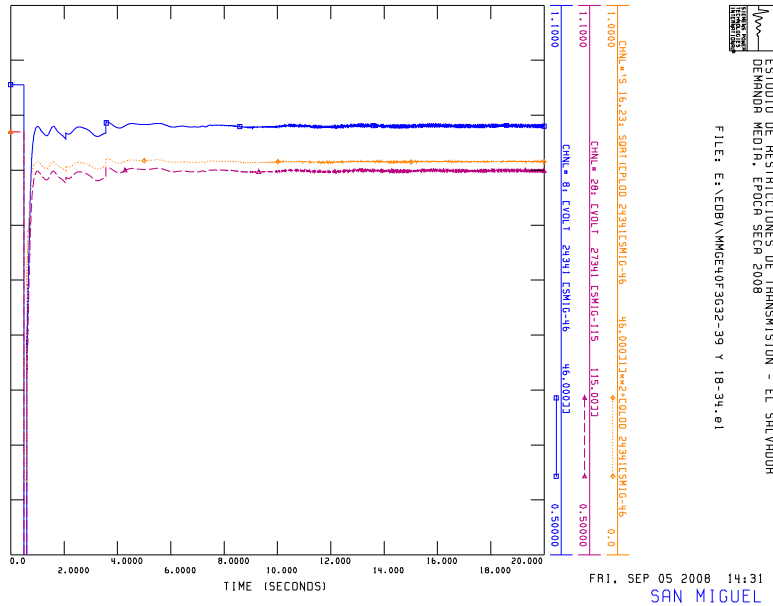

SUB	Disparo esperado	V _{ini}	S _{ini}	Etapa	V _{fin}	S _{fin}	ΔS	AJUSTE	
TECO	2	0.874	13.9	1,2	0.898	6.6	-7.3		
OZAT	2	0.886	16.6	1	0.904	13.5	-3.1		
SMIG	0	0.909	70.5	x	0.92	71.3			

4.7.10. Falla trifásica y disparo línea SRAF-TECO, NCUS-ATEO

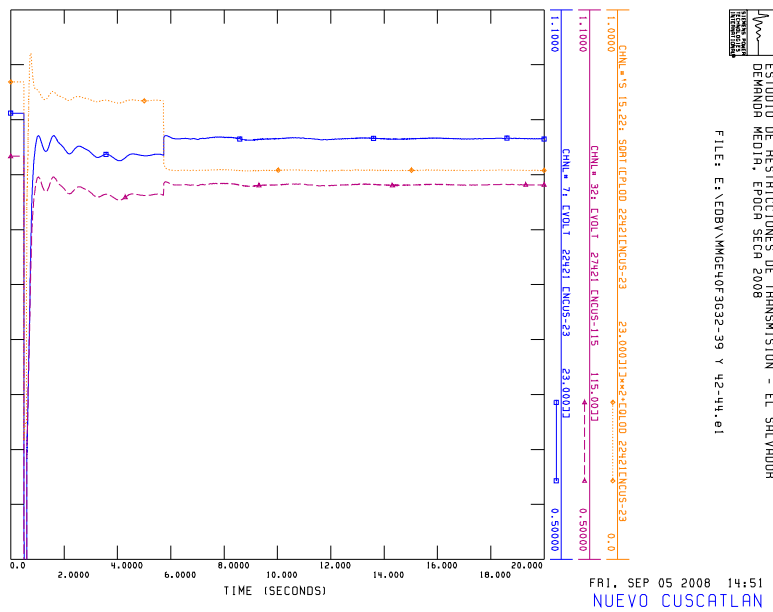

SUB	Disparo esperado	V _{ini}	S _{ini}	Etapa	V _{fin}	S _{fin}	ΔS	AJUSTE	
TECO	0	0.904	14.4	x	0.903	14.3			
OZAT	0	0.915	17.4	x	0.913	17.3			
NCUS		0.899	83.6	1	0.911	70.4	-13.2		

4.7.11. *Falla trifásica en bus 115 kV de ATEO y disparo de líneas NCUS-ATEO Y SANT-ATEO*

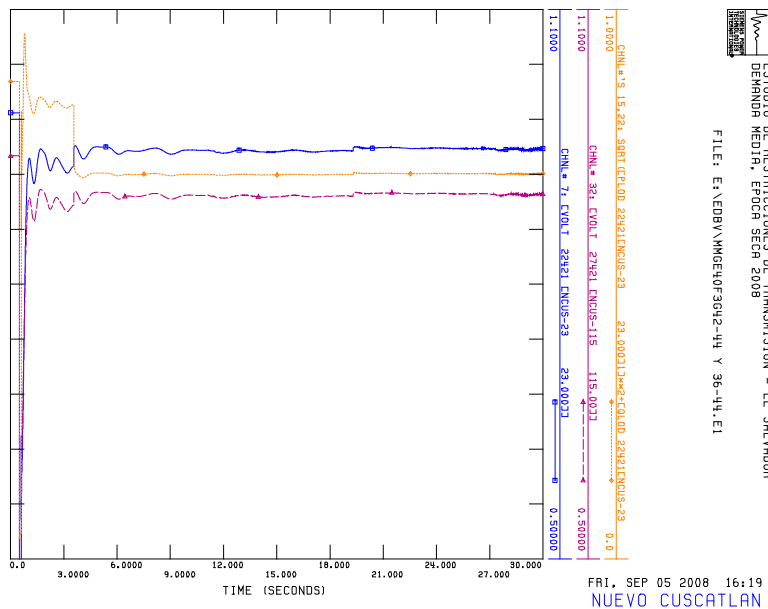
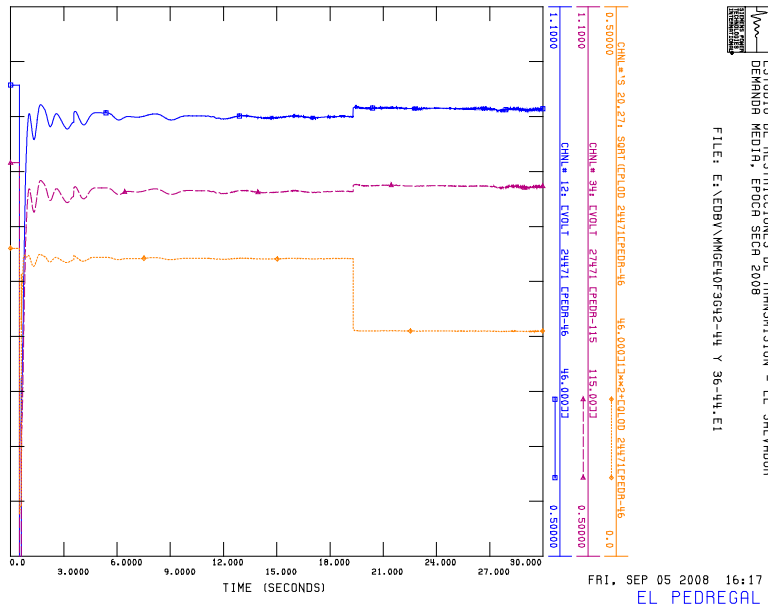

SUB	Disparo esperado	V _{ini}	S _{ini}	Etapa	V _{fin}	S _{fin}	ΔS	AJUSTE	
PEDR	1	0.899	26.9	1	0.903	20.5	-6.4		
NCUS	0	0.879	82	1	0.9	70.1	-11.9		
STOM	0	0.913	54.7	x	0.913	54.7			

4.7.12. Falla trifásica en línea SANT-ATEO, disparo de líneas SANT-NEJA Y ACAJ-ATEO

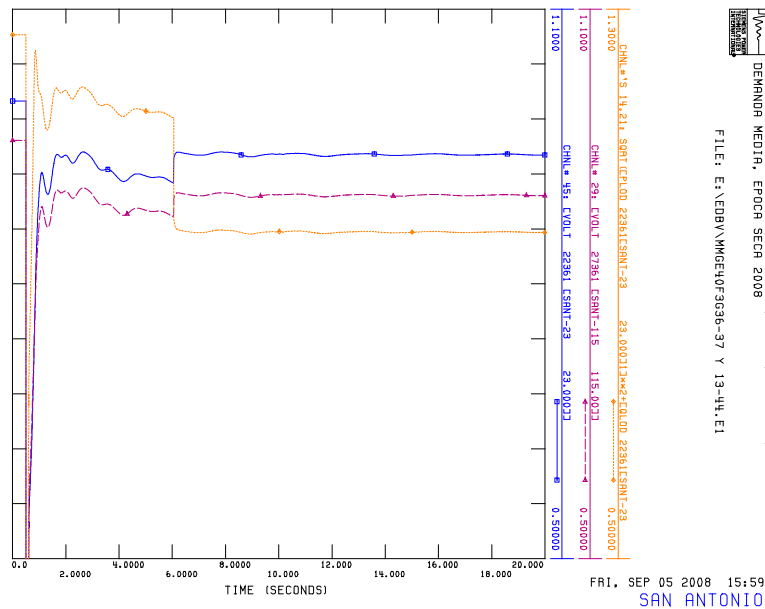

SUB	Disparo esperado	V _{ini}	S _{ini}	Etapa	V _{fin}	S _{fin}	ΔS	AJUSTE	
SANT	4	0.877	115	1	0.899	98.1	-16.9		
PEDR	0	0.911	27.5	x	0.915	27.7			
STOM	0	0.924	55.6	x	0.93	55.7			
NCUS	0	0.907	84	x	0.916	84.6			

4.7.13. Falla trifásica y disparo de línea SMAR-STOM y disparo de ACAJ-U5

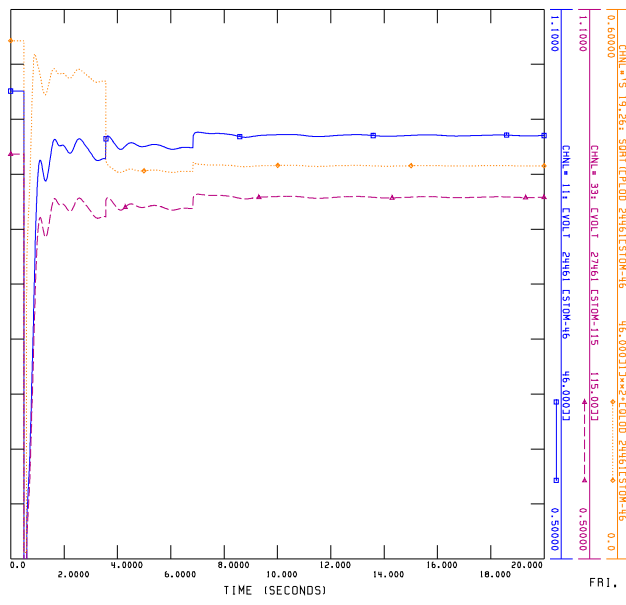
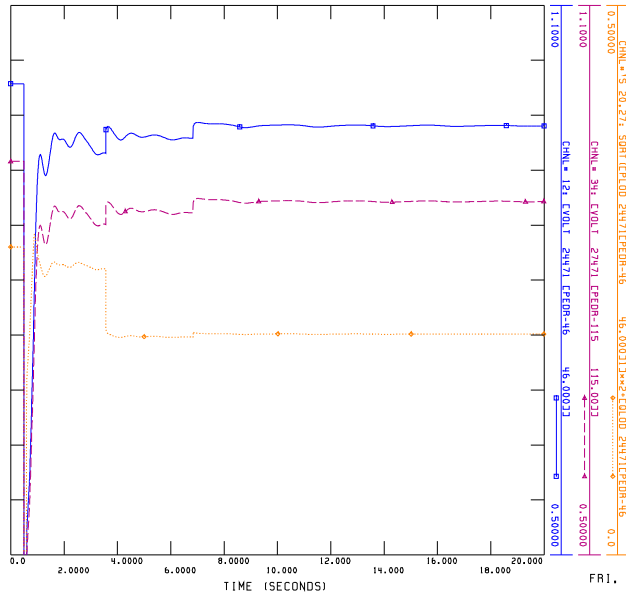

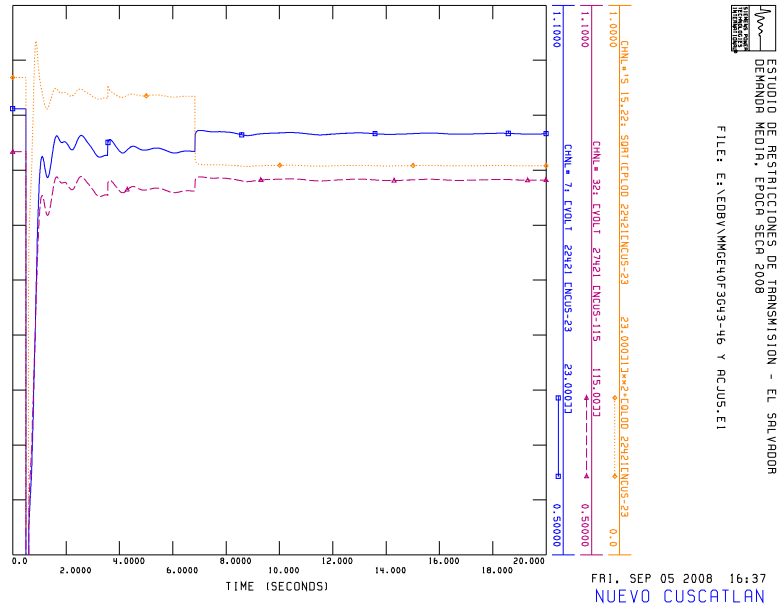

SUB	Disparo esperado	V _{ini}	S _{ini}	Etapa	V _{fin}	S _{fin}	ΔS	AJUSTE	
PEDR	7	0.860	26.1	1	0.867	20.1	-6		
STOM	8	0.874	51.9	1	0.895	42.9	-9		
NCUS	7	0.896	83.2	1	0.909	70.7	-12.5		

4.7.14. Falla trifásica en línea NCUS-ATEO, disparo de líneas ACAJ-ATEO y SMAR-STOM

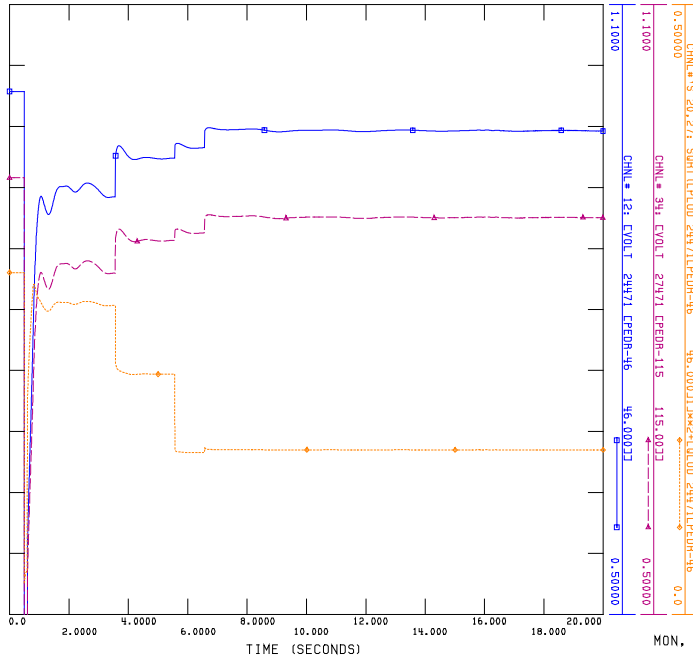

ESTUDIO DE RESTRICCIONES DE TRANSMISION - EL SALVADOR
DEMANDA MEDIA, EPOCA SECA 2008
FILE: E:\EDBY\MNGE40F3G43-46Y13-44.E1

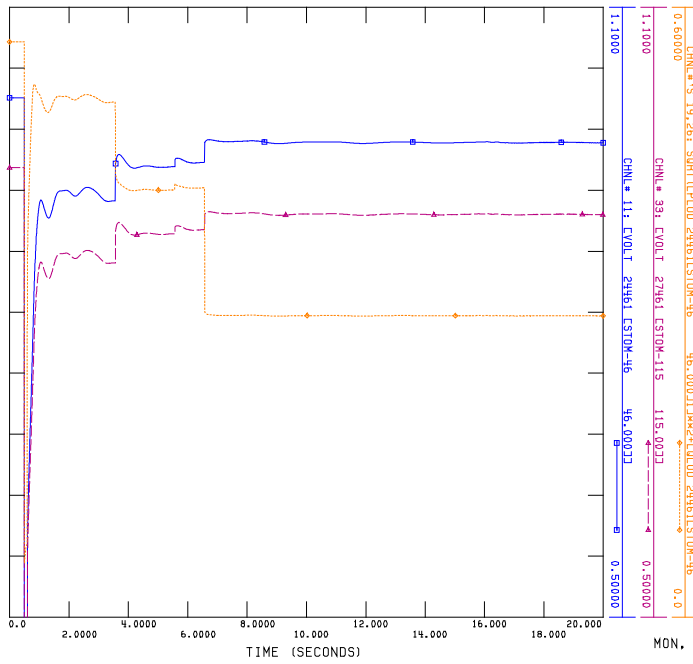

ESTUDIO DE RESTRICCIONES DE TRANSMISION - EL SALVADOR
DEMANDA MEDIA, EPOCA SECA 2008
FILE: E:\EDBY\MNGE40F3G43-46Y13-44.E1

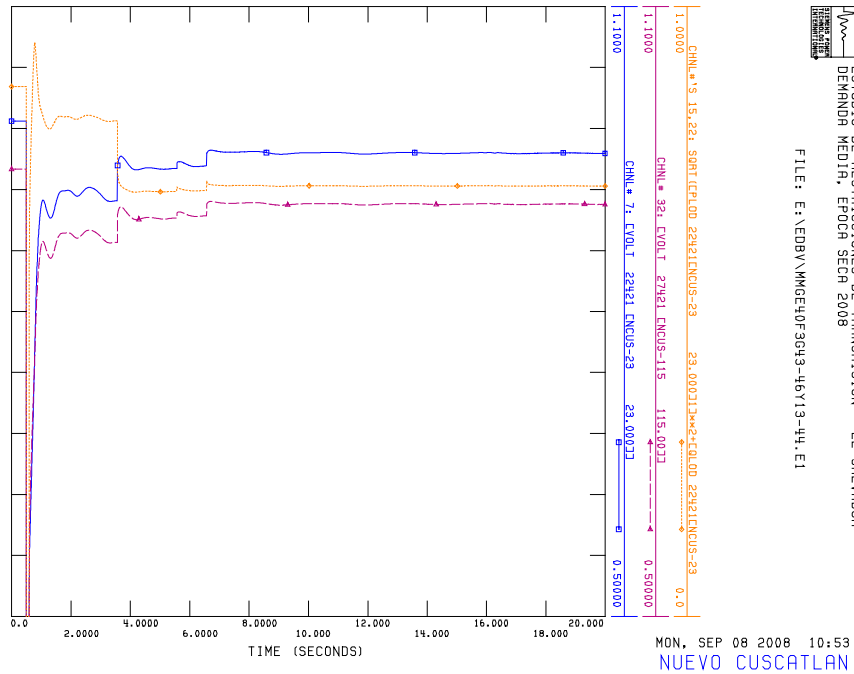

SUB	Disparo esperado	V _{ini}	S _{ini}	Etapa	V _{fin}	S _{fin}	ΔS	AJUSTE	
								V _{N-1} =	%S =
PEDR	6	0.835	25.3	1,3	0.891	19.1	-6.2	0.889	25
STOM	5	0.848	50.7	1	0.896	29.7	-21		
NCUS	0	0.867	81.2	1	0.906	70.7	-10.5		

4.7.15. Falla trifásica en bus 115 kV de SMIG, disparo de líneas 15SE-SMIG & BERL- SMIG.

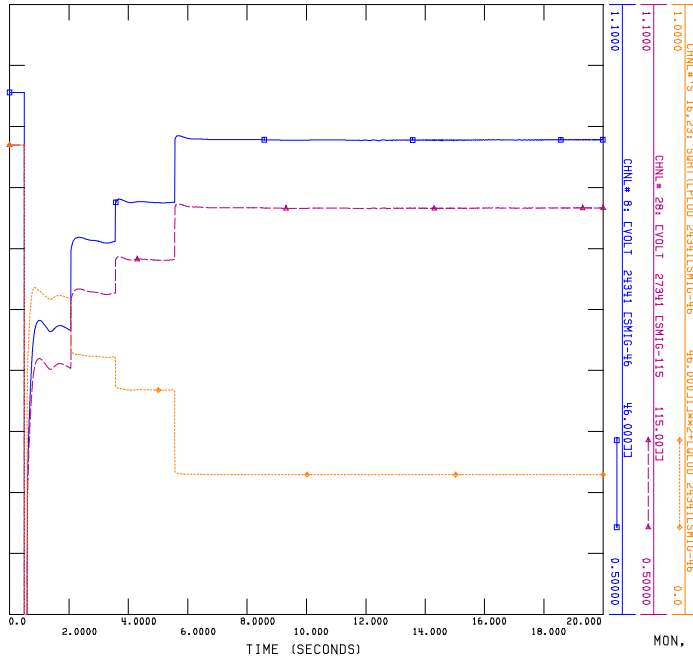

MON, SEP 08 2008 11:47
SAN MIGUEL

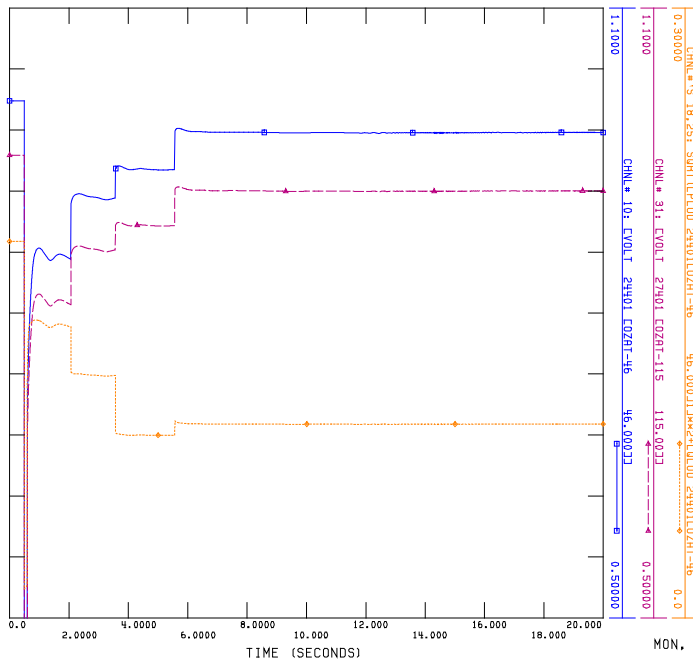

MON, SEP 08 2008 11:48
OZATLAN

SUB	Disparo esperado	V _{ini}	S _{ini}	Etapa	V _{fin}	S _{fin}	ΔS	AJUSTE	
SMIG		0.746	51.9	1,2,3	0.9	23.2	-28.7	%Ls	30%
OZAT		0.811	14.5	1,2	0.919	9.5	-5		
TECO		0.888	14.1	x	0.943	15.3			

4.7.16. Falla trifásica en bus 115 kV de NCUS, disparo de líneas SMAR-STOM & SANT-NEJA.

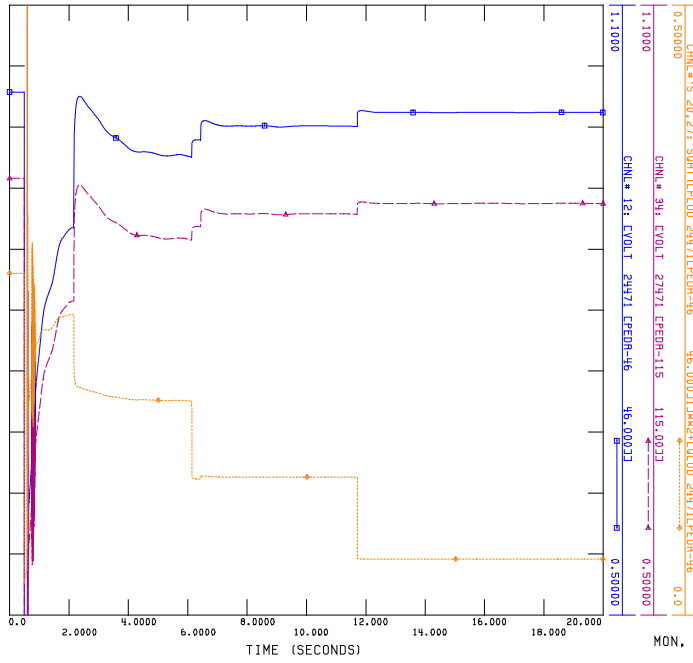

ESTUDIO DE RESTRICCIONES DE TRANSMISION - EL SALVADOR
DEMANDA MEDIA, EPOCA SECA 2008
FILE: E:\EDBY\VMGE\F0F3G43-46 Y 36-37.E1

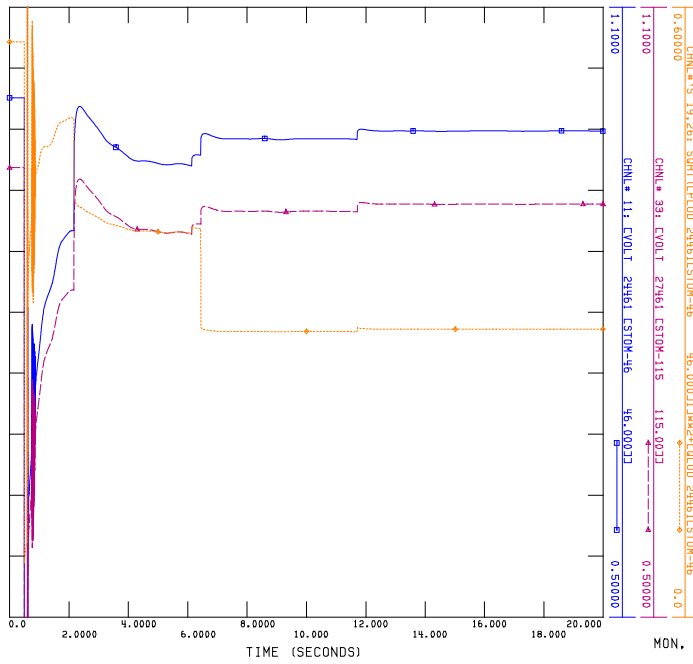

ESTUDIO DE RESTRICCIONES DE TRANSMISION - EL SALVADOR
DEMANDA MEDIA, EPOCA SECA 2008
FILE: E:\EDBY\VMGE\F0F3G43-46 Y 36-37.E1

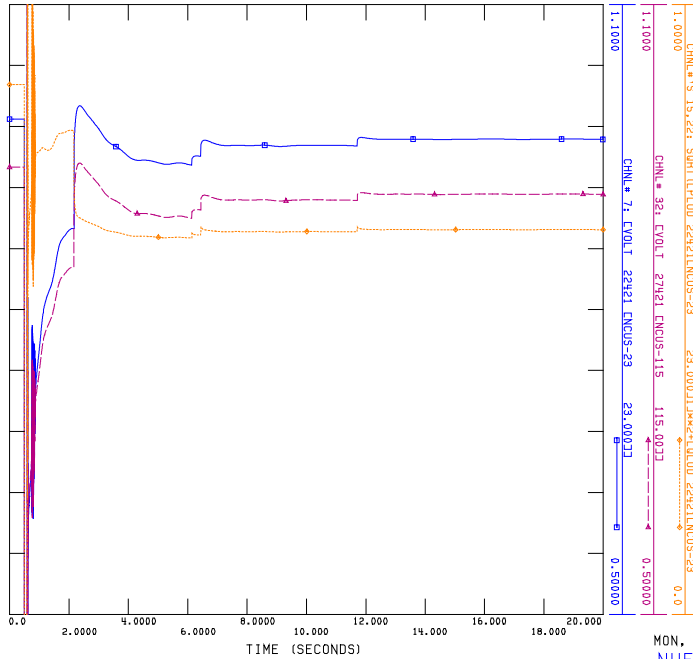

MON, SEP 08 2008 14:19
NUEVO CUSCATLAN

ESTUDIO DE RESTRICCIONES DE TRANSMISION - EL SALVADOR
DEMANDA MEDIA, EPOCA SECA 2008
FILE: E:\EDBY\MGE\F0F3043-46 Y 36-37.E1

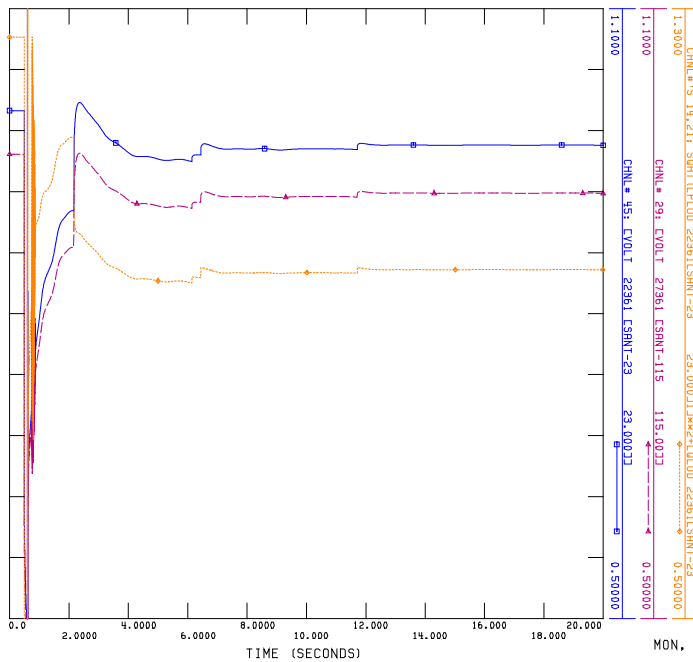

MON, SEP 08 2008 14:20
SAN ANTONIO

ESTUDIO DE RESTRICCIONES DE TRANSMISION - EL SALVADOR
DEMANDA MEDIA, EPOCA SECA 2008
FILE: E:\EDBY\MGE\F0F3043-46 Y 36-37.E1

SUB	Disparo esperado	V _{ini}	S _{ini}	Etapa	V _{fin}	S _{fin}	ΔS	AJUSTE	
PEDR	Ind	<0.8	24.4	1,2,3	0.904	4.5	-19.9	V _{N-1}	0.899
STOM	Ind	<0.82	49.1	1,2	0.906	28.3	-20.8		

NCUS	Ind	<0.84	79.6	2	0.912	63.1	-16.5		
SANT	Ind	<0.86	113	2	0.919	95.7	-17.3		

4.7.17. Falla trifásica en bus 115 kV de OZAT, disparo de líneas BERL-SMIG & SRAF-TECO.

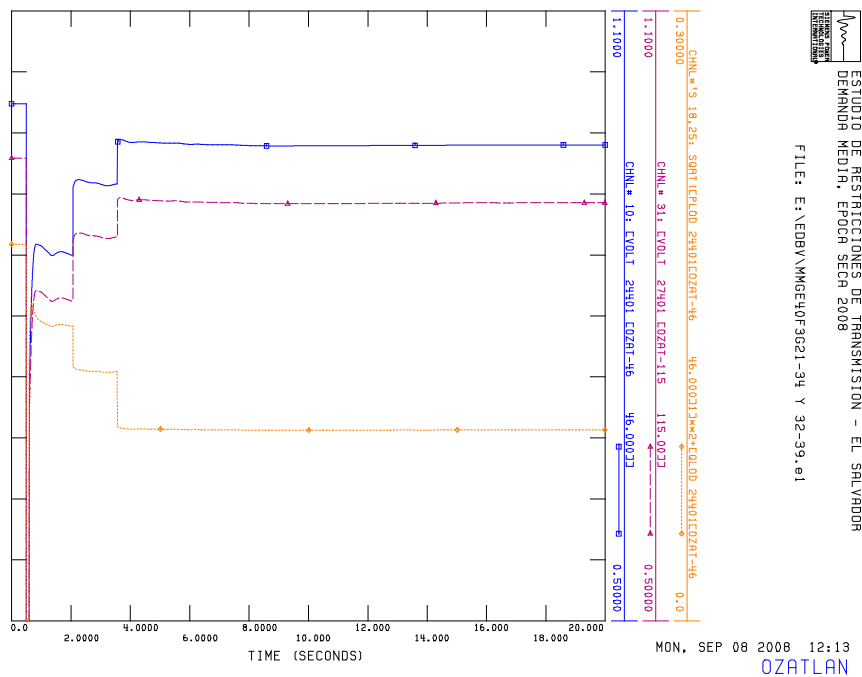
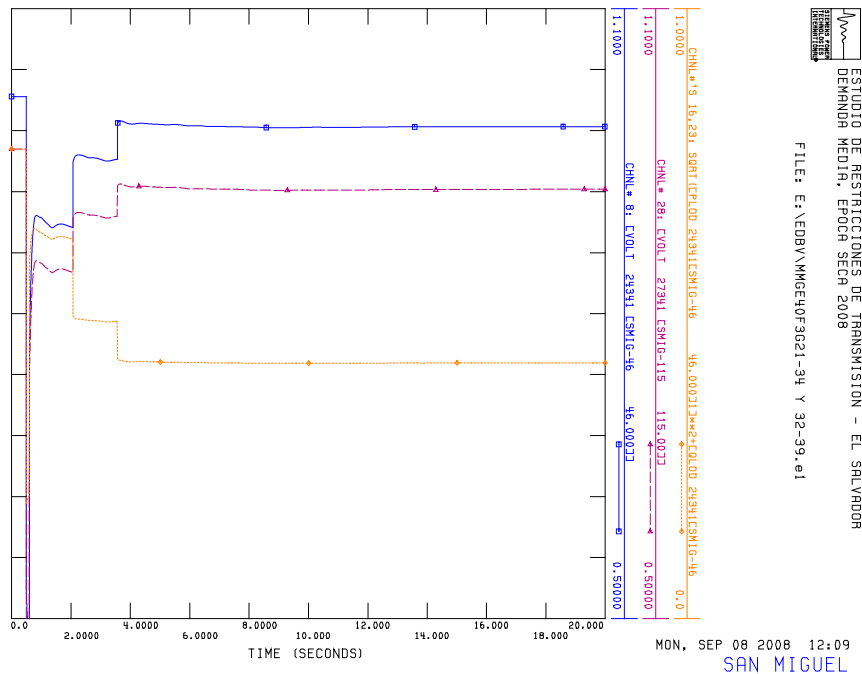

SUB	Disparo esperado	V _{ini}	S _{ini}	Etapa	V _{fin}	S _{fin}	ΔS	AJUSTE	
TECO		0.806	12.6	1,2	0.909	6.8	-5.8		
OZAT		0.815	14.5	1,2	0.911	9.4	-5.1		
SMIG		0.844	62.5	1,2	0.921	42.1	-20.4		

4.8. Verificación de reserva de potencia reactiva

SUB	CASO	Inferior				
		P _{shed}	Q	Q _{load}	M.R.	% shed
NCUS	2	SMAR-STOM & ACAJ-ATEO	40	49	9	
OZAT	7	SRAF-TECO & 15SE-SMIG				
PEDR	2	SMAR-STOM & ACAJ-ATEO				
SANT	9	SANT-NEJA & ACAJ-ATEO				
SMIG	1	BERL-SMIG & SMIG-OZAT				
STOM	2	SMAR-STOM & ACAJ-ATEO				
TECO	7	SRAF-TECO & 15SE-SMIG				